



S35 Color Display

CE*

Operations Manual

*This product bears the CE mark and complies with all applicable requirements of the European Union directives.

This display has been tested and approved for electromagnetic compatibility (EMC) and electromagnetic interference (EMI) in accordance with ISO 13766 and ISO 14982 standards.

This product complies with the EU REACH Regulation.

This product complies with the EU RoHS Directive (2011/65/EU and 2015/863).

To consistently bring you the highest quality, full-featured products, we reserve the right to change our specifications and designs at any time.

Warranty - A limited warranty on materials and workmanship is given with this Enovation Controls product. A copy of the warranty may be viewed or printed by going to www.enovationcontrols.com/warranty



ENOVATION CONTROLS has made efforts to ensure the reliability of the S35 and to recommend safe use practices in system applications. Please note that in any application, operation and controller failures can occur. These failures might result in full control outputs or other outputs that might cause damage to or unsafe conditions in the equipment or process connected to the S35.

Good engineering practices, electrical codes and insurance regulations require that you use independent external protective devices to prevent potentially dangerous or unsafe conditions. Assume that the S35 can fail with outputs full ON, outputs full OFF or that other unexpected conditions can occur.

Please read the following information before operating the S35:

- Observe all Warnings and Cautions in each section of these instructions.
- The S35 is designed for use in industrial environments. There might be potential difficulties in ensuring electromagnetic compatibility in other environments due to conducted as well as radiated disturbances.
- Please contact ENOVATION CONTROLS immediately if you have any questions.

IMPORTANT! False or improper use and operation of electronic products could be dangerous. It is required that point-of-operation guarding devices be installed and maintained. All such devices must meet OSHA and ANSI Machine safety standards. The manufacturer shall not accept any responsibility for installation, application or safety of systems.

Table of Contents

Introduction	5
Engine and Emissions Parameters	5
Navigation and Keypad Functions.....	5
Application	7
First-Time Startup	8
Customizing the Logo	8
Non-Menu Screens	9
Supported Parameters	12
Data Trouble Codes (DTC)	14
Alert and Warning Icons	16
Software Updates	17
From a Computer	17
From a USB Memory Stick.....	18
Software Revision Details	18
Pinout and Wiring Information	19
S35 Pinouts.....	19
S35 Typical Wiring Diagram.....	20
Display and Accessory Part Numbers	20
Specifications	21
Menu Setup	22
Menu 1 – Display	23
Menu 2 – Customize Interface	27
Menu 3 – Engine	29
Menu 4 – Throttle	33
Menu 5 – IO	36
Menu 6 - System	40
Menu 7 - Communication Setup.....	41
Final Screen – Notification	45
PC Configuration Tool	46
Display Tab	46
Customize Interface Tab	46
Add J1939 Parameters Tab	48
DTC Tab.....	48

LENS CLEANING PROCEDURES



The lens on the S35 is composed of polycarbonate materials. Use only mild soap and water to clean the lens/display window. Evidence of improper cleaning techniques or chemicals includes cracks, smear marks, scratches or fogged/hazy lenses.



Special Thanks to Eric Carmen for his invaluable research and How-To videos available on the Enovation Controls' Support website, support.enovationcontrols.com.

Introduction

Congratulations on purchasing the S35 Tactile Button display. Designed for the toughest environments, this compact 3.5-inch display brings a fresh look and feel while delivering the rugged performance you expect from Enovation Controls. This advanced tool provides clear visibility even when in direct sunlight. The S35 comes out of the box as a functional engine monitoring instrument with an easy-to-use software application for customization while supporting CAN J1939 and RS485 to ensure integration with various applications. Digital outputs can be controlled effortlessly while monitoring analog, resistive and frequency inputs. Four tactile buttons provide precise control even in the harshest environments.

This manual was developed to help you become familiar with the S35 display, identify navigation basics and recognize useful options and features.

Engine and Emissions Parameters





The following are some of the 77 engine and emission parameters that can be displayed on the S35:

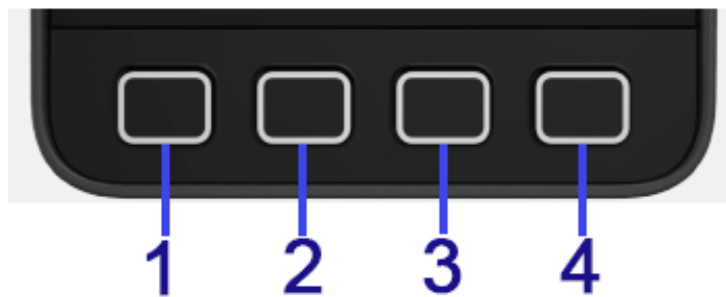

Intercooler Temperature	Fuel Level	Engine Oil Level
Barometric Pressure	Charging System Voltage	Engine Torque
DPF Lamp Status	DPF Soot Load	Exhaust High Temp
Amber Warning Lamp Status	Engine Ignition Timing	Trip Distance

Navigation and Keypad Functions





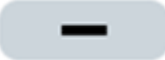



When directed to press a symbol within the procedural steps, it is referring to the button below the displayed symbol. Each display button is contextual and may have alternating functions within the configuration. The following table shows some of the functions each button may represent.

Button 1	Function
	Returns to the previous screen.
	Displays the Main Menu entrance point.
	Decreases the Throttle set point.
	Cancels a change.
	When on the DM2 screen, issues a fault request.

Button 2	Function
	Moves the highlighting to the previous field up one selection and displays the previous screen outside of the menu.
	Decreases the selected number, as in the Passcode screen.
	When blank, this button will be inoperable.
	Instantly moves to the DM2 screen.

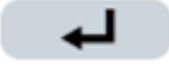
Continued

Button 3	Function
	Moves the highlighting to the next field down and displays the next screen outside of the menu.
	When blank, this button will be inoperable.
	Increases the selected number, as in the Passcode screen
	Instantly moves to the DM1 screen.

Button 4	Function
	Serves as the Enter button. To go into a highlighted menu showing a right arrow or to accept the changed parameter, press this button.
	When blank, this button will be inoperable.
	Appears on the IO Status screen when no engine is connected or a connected engine is not running. Pressing this button will activate the Crank output.
	Increases the Throttle set point.
	Appears on one of the main screens when the connected engine is running. Pressing this button will deactivate the ECU Enable output.

Application

The S35 can be used on any J1939 CAN-based electronic engine driven application to monitor engine parameters and fault codes.

Start and Stop the engine from the display by manual operator button control using the digital outputs. These must be connected to relays to drive the starter and ECU enable.

Throttle the engine over CAN from the operator button control, featuring two preset speeds or variable speed selection.

Control emissions DPF regeneration to force or inhibit regeneration.

Use in conjunction with the SenderCAN Plus to monitor parameters not managed by the engine ECU. Transmission parameters are a common example.

First-Time Startup

When power is applied to the S35, the Enovation Control logo displays along with a QR code.



Scan the QR code to access the support site and software updates.
Firmware: v002.22.28

Customizing the Logo

Follow these steps to create and upload a custom logo to the S35:

Step	Action
1	Create a custom logo using graphics software like MS Paint, set to 200 pixels wide x 100 pixels tall and 24-bit color.
2	Save the file as a bitmap image with the file name "logo.bmp".
3	Connect the display to your computer with a USB-C cable and launch a browser window to drag and drop the logo.bmp file onto the display's file system.
4	Power cycle the display and the new logo will automatically appear.

NOTE: This can also be accomplished within the PC Configuration Tool where you may select any image and it will automatically rescale to the correct size. Learn about the PC Configuration Tool in [this](#) section at the end of this document.

Non-Menu Screens

After Start Up, the Main Screens will be displayed. Screens can be cycled through using the left and right arrow buttons.

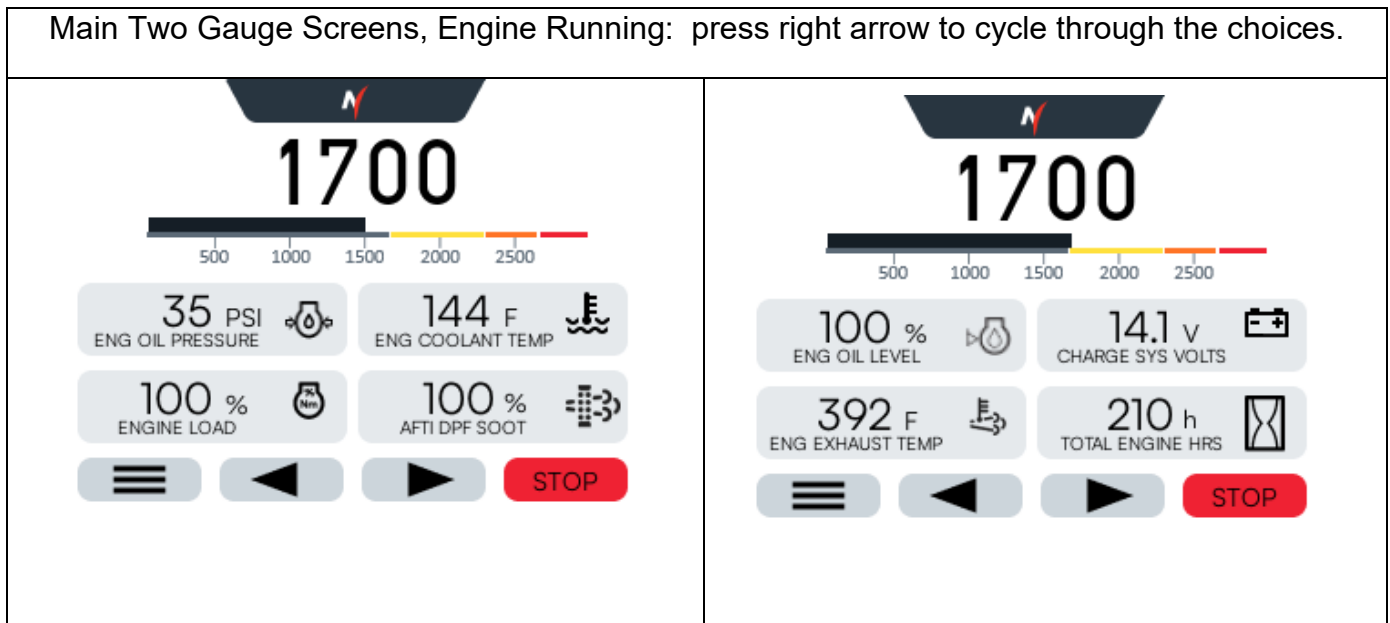
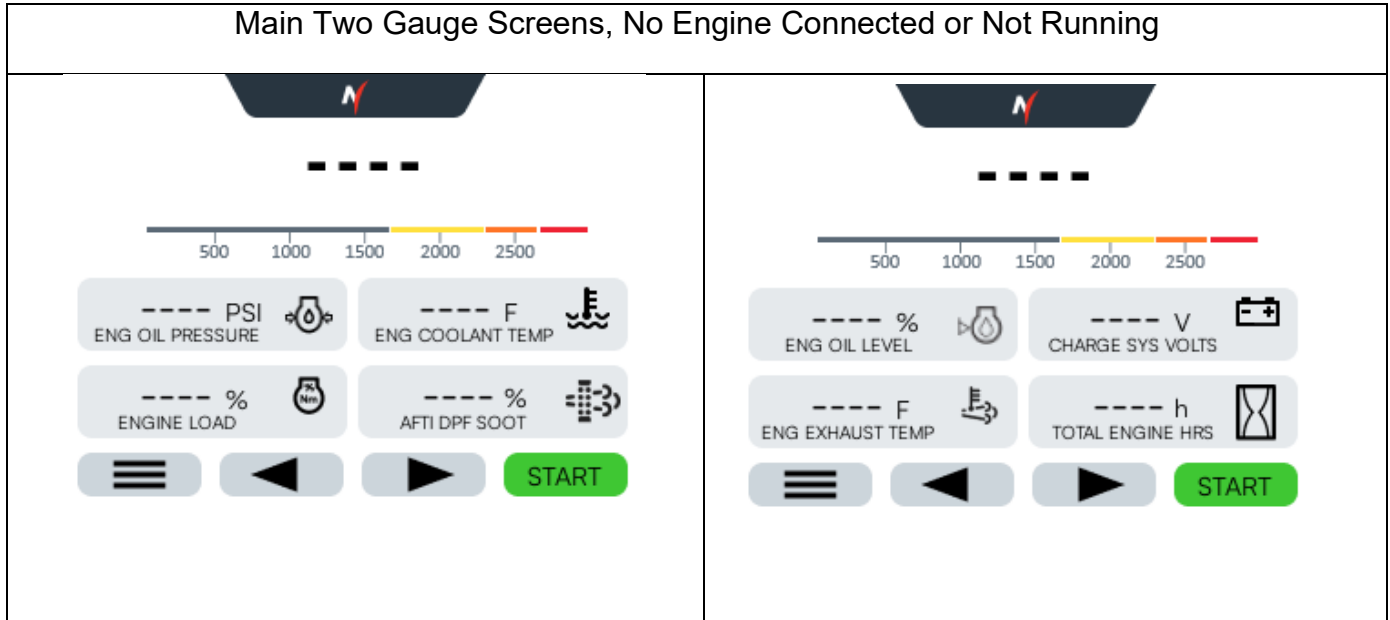

Continued

Regen Screens: press right arrow to cycle through the choices (Auto, Force and Inhibit).

<p>REGEN</p> <p>PRESS AUTO TO CANCEL INHIBIT</p> <p>110 % AFTI DPF SOOT</p> <p>144 F ENG COOLANT TEMP</p> <p>752 F ENG EXHAUST TEMP</p> <p>1200 RPM ENGINE SPEED</p> <p>AUTO FORCE INHIBIT</p> <p>Navigation icons: menu, left, right, back</p>	<p>REGEN</p> <p>PRESS AUTO TO CANCEL INHIBIT</p> <p>110 % AFTI DPF SOOT</p> <p>144 F ENG COOLANT TEMP</p> <p>752 F ENG EXHAUST TEMP</p> <p>1200 RPM ENGINE SPEED</p> <p>AUTO FORCE INHIBIT</p> <p>Navigation icons: menu, left, right, back</p>
<p>REGEN</p> <p>PRESS FORCE TO ATTEMPT REGEN</p> <p>110 % AFTI DPF SOOT</p> <p>144 F ENG COOLANT TEMP</p> <p>752 F ENG EXHAUST TEMP</p> <p>1200 RPM ENGINE SPEED</p> <p>AUTO FORCE INHIBIT</p> <p>Navigation icons: menu, left, right, back</p>	<p>REGEN</p> <p>PRESS INHIBIT TO CANCEL REGEN</p> <p>110 % AFTI DPF SOOT</p> <p>144 F ENG COOLANT TEMP</p> <p>752 F ENG EXHAUST TEMP</p> <p>1200 RPM ENGINE SPEED</p> <p>AUTO FORCE INHIBIT</p> <p>Navigation icons: menu, left, right, back</p>

Continued

Note: If in the Hide/Show menu the SenderCAN Plus Screen is set to ON, the user will see the SCP IO STATUS screen after the I/O STATUS screen:

IO Status and SCP IO Status

IO STATUS			SCP IO STATUS		
PIN	DESCRIPTION	STATUS	WIRE	DESCRIPTION	STATUS
A04	Freq. Input	0	Green	Freq. Input	65535
A05	Analog Input 01	0	Blue	Digital Output 01 (low)	0
B01	Digital Output 01 (low)	0	Brown	Digital Output 02 (low)	0
B02	Digital Output 02 (low)	0	Purple	Analog Input 01	65535
B05	Analog Input 02	0	Orange	Analog Input 02	65535
			White	Analog Input 03	65535
			Grey	Analog Input 04	65535

☰ ◀ ▶ START

Engine Speed: Right arrow button cycles through Set Speed, Idle Speed, Preset Speed 1 and Preset Speed 2. Adjust the set speed limits using the and buttons.

<h4 style="background-color: #333; color: white; padding: 2px;">ENGINE SPEED</h4> <div style="font-size: 2em; font-weight: bold; margin: 10px 0;">1222</div> <div style="display: flex; justify-content: center; gap: 20px; margin-bottom: 10px;"> 500 1000 1500 2000 2500 </div> <div style="display: flex; justify-content: space-around; margin-bottom: 10px;"> <div style="background-color: #333; color: white; padding: 5px; border-radius: 5px;">700 rpm <small>SET SPEED</small></div> <div style="background-color: #ccc; padding: 5px; border-radius: 5px;">700 rpm <small>IDLE SPEED</small></div> </div> <div style="display: flex; justify-content: space-around; margin-bottom: 10px;"> <div style="background-color: #ccc; padding: 5px; border-radius: 5px;">1200 rpm <small>PRESET SPEED 1</small></div> <div style="background-color: #ccc; padding: 5px; border-radius: 5px;">2000 rpm <small>PRESET SPEED 2</small></div> </div> <div style="display: flex; justify-content: center; gap: 10px;"> ◀ ▶ </div>	<h4 style="background-color: #333; color: white; padding: 2px;">ENGINE SPEED</h4> <div style="font-size: 2em; font-weight: bold; margin: 10px 0;">1222</div> <div style="display: flex; justify-content: center; gap: 20px; margin-bottom: 10px;"> 500 1000 1500 2000 2500 </div> <div style="display: flex; justify-content: space-around; margin-bottom: 10px;"> <div style="background-color: #ccc; padding: 5px; border-radius: 5px;">700 rpm <small>SET SPEED</small></div> <div style="background-color: #333; color: white; padding: 5px; border-radius: 5px;">700 rpm <small>IDLE SPEED</small></div> </div> <div style="display: flex; justify-content: space-around; margin-bottom: 10px;"> <div style="background-color: #ccc; padding: 5px; border-radius: 5px;">1200 rpm <small>PRESET SPEED 1</small></div> <div style="background-color: #ccc; padding: 5px; border-radius: 5px;">2000 rpm <small>PRESET SPEED 2</small></div> </div> <div style="display: flex; justify-content: center; gap: 10px;"> ◀ ▶ </div>
<h4 style="background-color: #333; color: white; padding: 2px;">ENGINE SPEED</h4> <div style="font-size: 2em; font-weight: bold; margin: 10px 0;">1222</div> <div style="display: flex; justify-content: center; gap: 20px; margin-bottom: 10px;"> 500 1000 1500 2000 2500 </div> <div style="display: flex; justify-content: space-around; margin-bottom: 10px;"> <div style="background-color: #ccc; padding: 5px; border-radius: 5px;">700 rpm <small>SET SPEED</small></div> <div style="background-color: #ccc; padding: 5px; border-radius: 5px;">700 rpm <small>IDLE SPEED</small></div> </div> <div style="display: flex; justify-content: space-around; margin-bottom: 10px;"> <div style="background-color: #333; color: white; padding: 5px; border-radius: 5px;">1200 rpm <small>PRESET SPEED 1</small></div> <div style="background-color: #ccc; padding: 5px; border-radius: 5px;">2000 rpm <small>PRESET SPEED 2</small></div> </div> <div style="display: flex; justify-content: center; gap: 10px;"> ◀ ▶ </div>	<h4 style="background-color: #333; color: white; padding: 2px;">ENGINE SPEED</h4> <div style="font-size: 2em; font-weight: bold; margin: 10px 0;">1222</div> <div style="display: flex; justify-content: center; gap: 20px; margin-bottom: 10px;"> 500 1000 1500 2000 2500 </div> <div style="display: flex; justify-content: space-around; margin-bottom: 10px;"> <div style="background-color: #ccc; padding: 5px; border-radius: 5px;">2000 rpm <small>SET SPEED</small></div> <div style="background-color: #ccc; padding: 5px; border-radius: 5px;">700 rpm <small>IDLE SPEED</small></div> </div> <div style="display: flex; justify-content: space-around; margin-bottom: 10px;"> <div style="background-color: #ccc; padding: 5px; border-radius: 5px;">1200 rpm <small>PRESET SPEED 1</small></div> <div style="background-color: #333; color: white; padding: 5px; border-radius: 5px;">2000 rpm <small>PRESET SPEED 2</small></div> </div> <div style="display: flex; justify-content: center; gap: 10px;"> ◀ ▶ </div>

Supported Parameters

The following parameters are currently supported in the standard application as of version 1.0.0. These parameters can be displayed on any of the gauges by selecting them from the menu. Additional parameters can be added by creating a custom application (see your distributor for details).

SPN	Description
22	Extended Crankcase Blow-by Pressure
51	Throttle Valve 1 Position
52	Intercooler Temperature
84	Wheel Based Vehicle Speed
91	Accelerator Pedal Position 1
92	Engine % Load at Current RPM
94	Fuel Delivery Pressure
96	Fuel Level 1
98	Engine Oil Level
100	Engine Oil Pressure
101	Crankcase Pressure
102	Intake Manifold 1 Pressure
105	Intake Manifold 1 Temperature
106	Air Inlet Pressure
107	Air Filter 1 Differential Pressure
108	Barometric Pressure
109	Engine Coolant Pressure 1
110	Engine Coolant Temperature
111	Engine Coolant Level 1
157	Fuel Injector Metering Rail 1 Pressure
158	Key Switch Battery Voltage
161	Transmission Input Shaft Speed
167	Charging System Voltage
168	Battery Potential Voltage
172	Air Inlet Temperature
173	Exhaust Temperature
174	Fuel 1 Temperature
175	Engine Oil Temperature
177	Transmission Oil Temperature
182	Trip Fuel
183	Fuel Rate

Continued

SPN	Description
184	Instantaneous Fuel Economy
185	Average Fuel Economy
190	Engine Speed (RPM)
191	Transmission Output Shaft Speed
244	Trip Distance
245	Total Vehicle Distance
247	Engine Hours
249	Engine Total Revolutions
250	Total Fuel Used
441	Aux Temperature 1
513	Actual Engine % Torque
515	Engine Desired Operating Speed (RPM)
523	Transmission Current Gear
524	Transmission Selected Gear
525	Transmission Requested Gear
558	Accelerator Pedal 1 Low Side Switch
573	Transmission Torque Converter Lockup Engaged
701	Aux I/O 1
975	Engine Fan 1 Estimated Speed
1387	Aux Press 1
1436	Engine Ignition Timing
1638	Hydraulic Temperature
1761	SCR Catalyst Tank Level 1 (DEF)
1762	Hydraulic Pressure
3031	DEF Tank Temperature
3242	DPF Intake Temperature
3246	DPF Outlet Temperature
3517	SCR Catalyst Tank Level 2 (DEF)
3697	Diesel Particular Filter (DPF) Lamp Status
3698	Exhaust System High Temp Lamp
3700	DPF Active Regeneration Status
3702	DPF Active Regeneration Inhibited
3719	DPF Soot Load %
3720	DPF Ash Load %
5078	Amber Warning Lamp Status
5079	Red Stop Lamp Status
5080	Malfunction Lamp Status
5082	Oil Pressure Low Lamp
5083	Coolant Temperature High Lamp
5245	Diesel Exhaust Fluid Low Level
5246	SCR Operator Inducement
6709	Speed High Lamp

Data Trouble Codes (DTC)

The S35 standard application will display currently active J1939 DM1 fault codes on a dedicated faults page sorted by SPN and FMI code. When a DM1 is detected a red exclamation mark is added to button 3. Upon pressing button 3 the DM1 screen will instantly appear. **The S35 does not shut the engine down** on a fault condition, all shutdowns will be generated by the engine ECM.

DM1 FAULTS 1/2			
SPN	FMI	OC	ADDRESS
3696	5	10	1
27	3	2	0

This screen shows two fault codes with the first fault highlighted.

Press the Enter key and more information about that highlighted fault will appear, if available.

DM1 FAULTS			
SPN	FMI	OC	ADDRESS
3696	5	10	1
DESCRIPTION			
Description unavailable			

SPN: Suspected Parameter Number – indicates what part of the system is reporting an error. See the [Supported Parameters](#) section for a partial list of SPN definitions. Contact equipment manufacturer for a full list.

FMI: Failure Mode Indicator – indicates the reported failure. See table below.

OC: Occurrence Count – how often the failure occurred.

Address: The source address (SA) of the device reporting the failure. SA 0 is used by the engine ECU. Transmissions use SA 3.

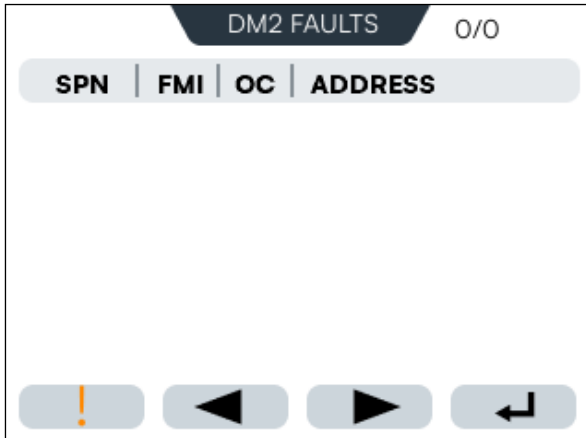

This DM2 screen is used for historical faults and is virtually the same as the DM1 screen. When a DM1 disappears before being acknowledged, an orange exclamation mark will appear on button 1. Pressing this button will send a DM2 request and the DM2 screen will appear on the screen.





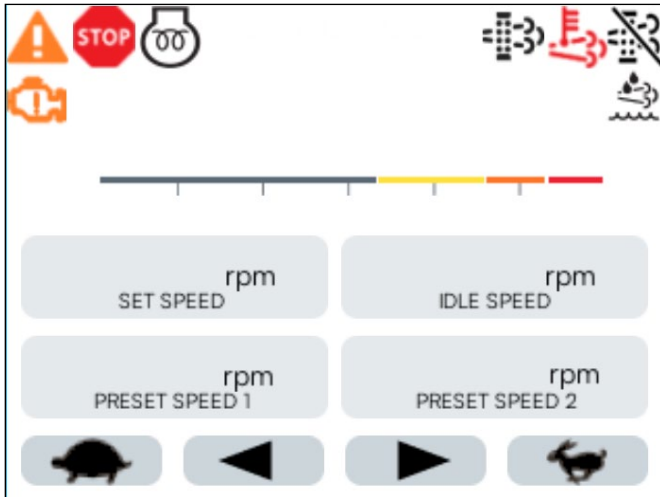

FMI	Description
0	Above Normal – Most Severe Level
1	Below Normal – Most Severe Level
2	Data Erratic or Incorrect
3	Voltage Above Normal or Shorted High
4	Voltage Below Normal or Shorted Low
5	Current Below Normal or Open Circuit
6	Current Above Normal or Shorted
7	Mechanical System not Responding or Out of Calibration
8	Abnormal Frequency or PWM Rate
9	Abnormal Update Rate
10	Abnormal Rate of Change
11	Problem Unknown
12	Bad ECM, Controller, or Smart Sensor
13	Out of Calibration
14	Special Instructions
15	Above Normal – Least Severe Level
16	Above Normal – Moderately Severe level
17	Below Normal – Least Severe Level
18	Below Normal – Moderately Severe Level
19	CAN Data Error
20	Data Drifted High
21	Data Drifted Low
22-30	Reserved for Future Use
31	Condition Exists

Alert and Warning Icons





Upon startup, this screen will flash briefly, showing the alert icons at the top.

Up to eight symbols can be shown at one time in the icon area to represent warnings, Tier 4 status and service indicators. The most important of these symbols will be shown in the upper left area.

Icon(s)	Function(s)
	Shutdown indicator
	Warning displays when an active and unacknowledged DTC warning or internal set point exists. Disappears when fault is acknowledged and no longer active.
	Displays when High Exhaust System Temperature (HEST) is active and exhaust temperature is above normal operating condition.
	Regen Inhibit (Regen Inhibit is restricted when a HEST alarm is present) displays when the engine ECU has inhibited a regeneration or a manual inhibit has been requested.
	Diesel Particulate Filter Lamp. Displays when engine after-treatment requires regeneration. This is as a result of the after-treatment filter reaching the engine manufacturer's set soot level.
	Low diesel exhaust fluid. Displays when the ECU transmits a low DEF level.
	Engine Emissions System Failure displays when an emissions after-treatment malfunction has occurred. Contact your local engine manufacturer's service department for direction.

Continued

Icon(s)	Function(s)
	Expired Service Reminder – appears next to the RPM gauge when a service reminder has expired.
	Wait to Start – On electronic engines only, if a preheat message is being actively broadcast from the Engine Control Unit (ECU), this symbol displays depending on the state of SPN 1081 from PGN 65252.

Software Updates

The S35 can be easily updated with this software using a USB-C Flash memory device, see instructions below. Typically, only the application needs to be updated.

From a Computer

Follow these steps to update the software from a computer:

Step	Action
1	Plug a USB cable between the S35 (USB-C) and a computer (USB-A or USB-C) and apply power.
2	Launch a Windows browser and select the USB connection that appears.
3	Delete the existing application .bin file.
4	Copy and paste the new .bin file onto the USB connected device. Do not rename the file.
5	Power cycle the display while holding the left button down and follow along with Step 2 shown in the table below (From a USB Memory Stick).

From a USB Memory Stick

Step	Action
1	Load the application .bin file on a USB Flash memory device and plug it into the display's USB port under the rubber grommet on the back of the display. Standard files can be found in the software dropdown menu from the Support.EnovationControls.com website titled "S35 Specifications & Operation."
2	Press and hold the left button while applying power. Release the button when the bootloader screen appears. The display will automatically scan for valid files on the USB drive.
3	Select YES to start the application installation or select NO to go back to normal operation.
4	The display will update the application and report a green verified check mark once complete. It is important not to interrupt power during this operation.
5	Display will reboot to the application when the installation is complete.

Software Revision Details

For the latest Software Revision details, visit our Support site and search for S35 at <https://support.enovationcontrols.com>.

Custom Application Software

Custom applications can be created by our premier distribution partners. Please visit our main website to find a distributor in your area.

Development tools and example source code are available to developers, please contact Enovation Controls or your distribution partner for access.

Pinout and Wiring Information

S35 Pinouts

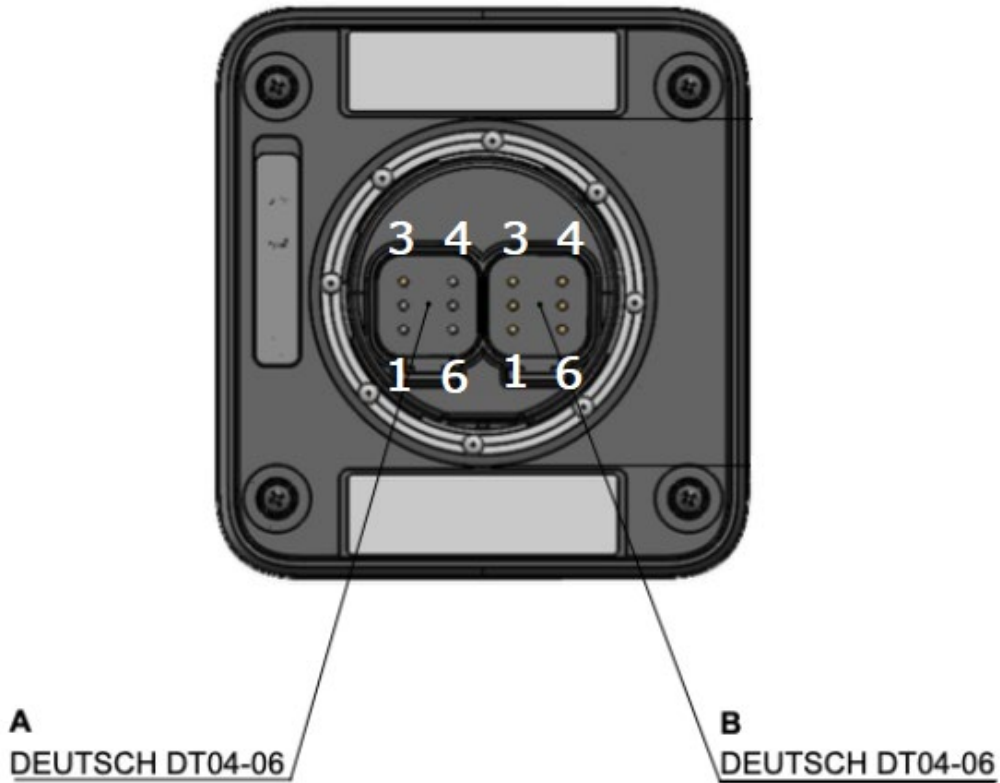

Port A			Port B	
Pin	Description		Pin	Description
1	Vbatt		1	Dig Output 1
2	CAN High		2	Dig Output 2
3	CAN Low		3	RS485 +
4	Freq Input		4	RS485 -
5	Analog Input 1		5	Analog Input 2
6	Ground		6	Analog Ground

S35 Typical Wiring Diagram

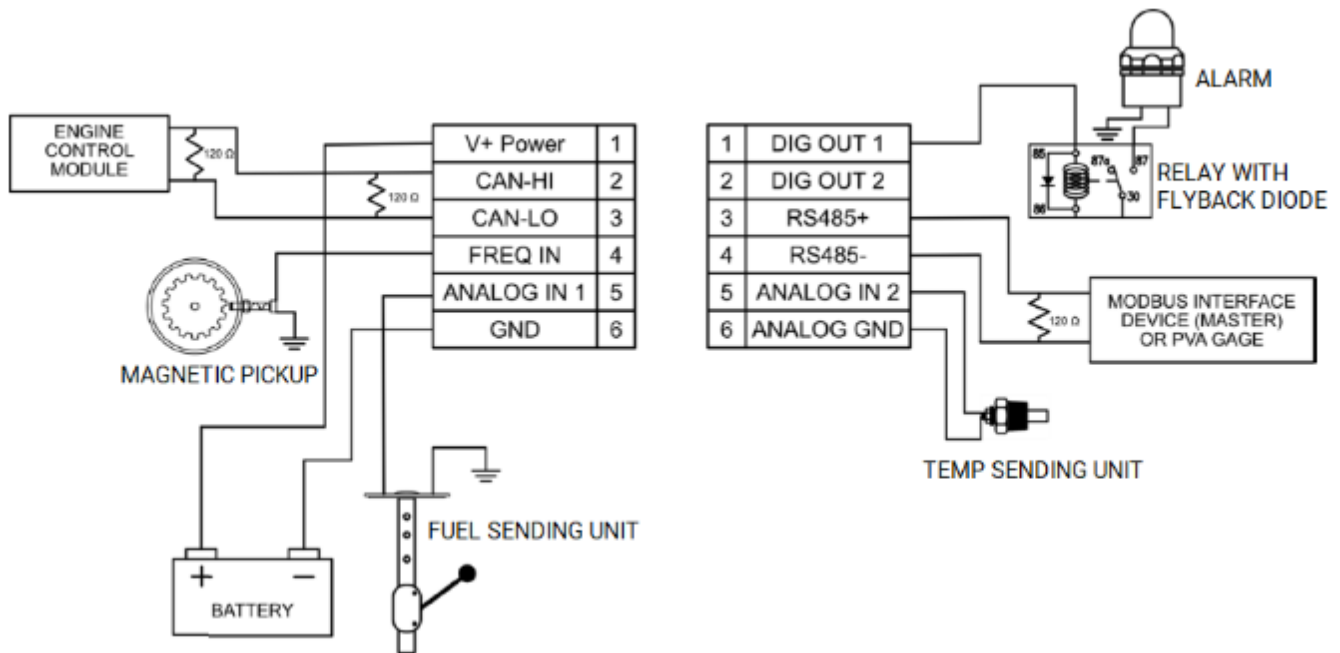

Display and Accessory Part Numbers

Part Number	Description
78700727	S35 Color Display
78900727	S35 Color Display (24 Pack)
38000022	Harness, Connector A, CAN/Power – Terminated, 3' pigtail
38000023	Harness, Connector B, I/O, 3' pigtail

Specifications

Computing

Processor	Arm® Cortex®-M33 microcontroller @ 160 MHz (32-bit)
Operating System	Free RTOS
Storage	1 MB Flash Memory
RAM	320 KB SRAM
Graphics	Integrated Graphics Controller

Display

Screen	3.5-inch Square, 24-bit color
Resolution	320 x 240 QVGA
Contract Ratio/Brightness	700 NITS
Touch Panel	4-tactile silicone buttons
Surface	Anti-glare finish

Interfaces

CAN	(1) CAN 2.0B according to ISO 11898-2, J1939 (Selectable 250k/500k/1Mb baud rate)
USB	(1) USB-C 2.0B full speed host
RS485	(1) HALF DUPLEX
Analog Inputs	(2) Software Selectable 0-5V, 4-20mA, or Resistive (0-1000 ohms)
Frequency Input	(1) Freq In (30Hz – 10KHz)
Outputs	(2) Digital Low-side open drain 500mA
Real Time Clock	Yes

Continued

Electrical / Environmental

Operating Voltage	6-36 VDC, Reverse polarity protected
Operating Temperature	-40°C to +85°C (-40°F to +185°F)
Storage Temperature	-40°C to +85°C (-40°F to +185°F)
Protection	IP67
Vibration	7.86 Grms (5-2000 Hz), 3-axes random
Shock	±50G, 3-axes

Physical

Mounting	2" SAE HOLE with ring nut
Connectors	(2) 6-pin Deutsch DT06-6 Connectors

Compliance

EMC/EMI	ISO 13755, ISO 14982
CE	Yes
REACH	Yes
RoHS	Yes

Menu Setup

Many of the S35 features are customizable through the menu, making it adaptable for specific applications.

Press the Menu button  and the Password screen will appear:

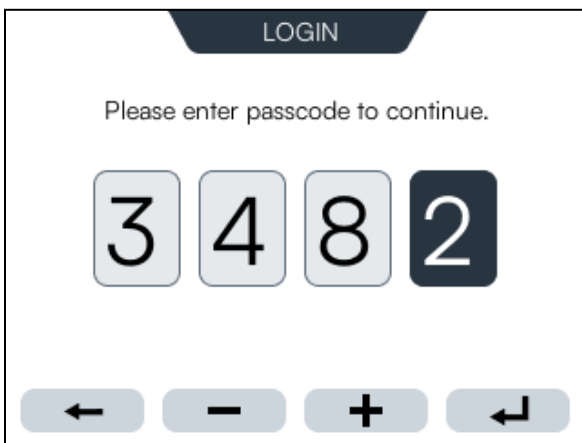

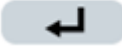
The highlighting will appear on the first number of the password. Use the + and – buttons to adjust the number, then press the  button to move the highlighting to the next field.

Repeat the process until the last number is filled

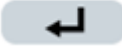
then press the  button once more to enter the Menu.

NOTE: No power cycle is needed. After saving and exiting the menu, the system applies the changes automatically.

Menu 1 – Display

These menu selections alter the appearance of the S35.



To enter a highlighted menu item, press the  button.

To scroll down, press the  button.

To scroll up, press the  button.

To display one previous screen, press the  button.

Brightness

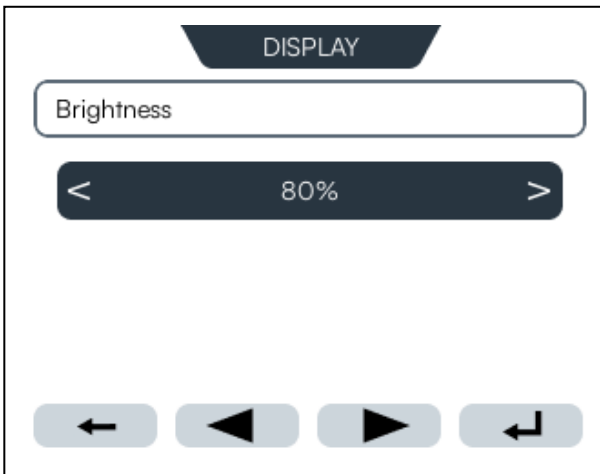

Press the right and left arrow buttons to adjust the Brightness percentage and press the  to set the new level.

Auto-Dim

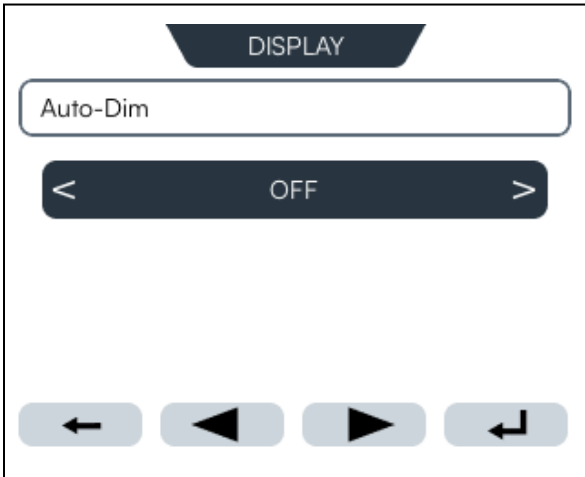

Auto-Dim will automatically dim the brightness of the screen after the specified time limit of no interaction.

Press the right and left arrows to select Off or increments of 1 to 30 minutes.

Press the  key to set your choice.

Dark Mode

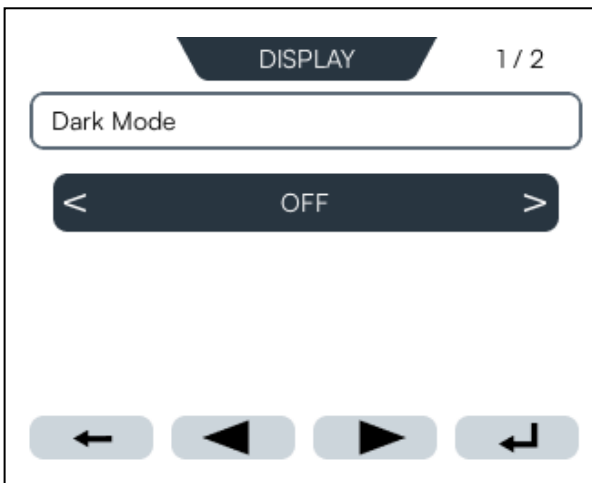

Dark Mode settings are Off and On. When On, the screens will appear with a black background instead of white:

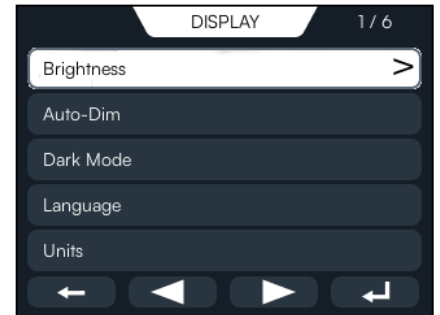

Press the  button to set your choice.

Language

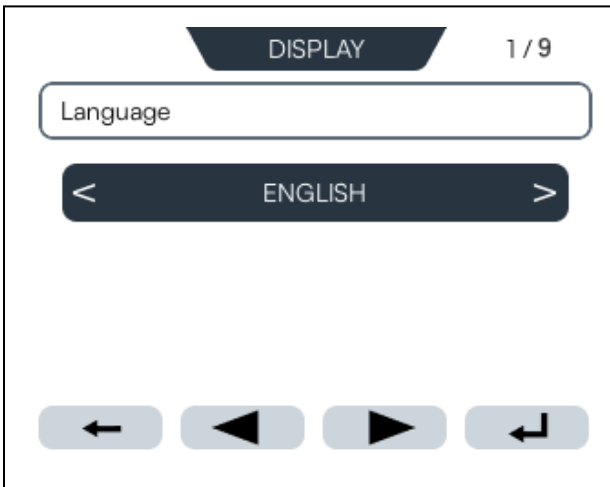

Select the preferred language for the display.

Choices are:

- ENGLISH
- FRENCH
- GERMAN
- SPANISH
- ITALIAN
- CHINESE
- KOREAN
- PORTUGUESE
- JAPANESE.

Press the  button to set your choice.

Units

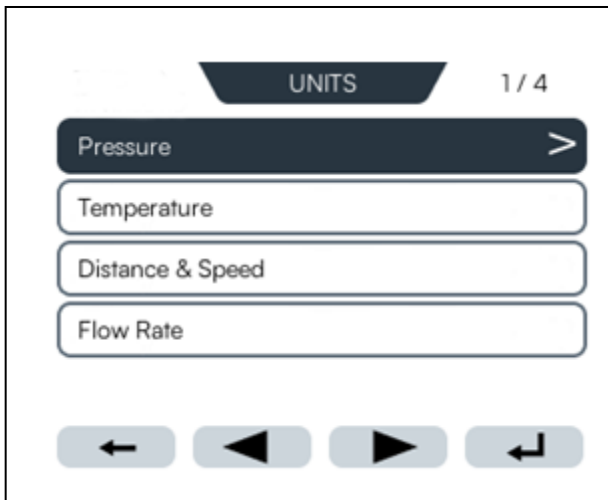

Within Units, select the desired measurement for Pressure, Temperature, Distance & Speed and Flow Rate.

For Pressure, select between J1939 Default (kPa), Metric (BAR) or Imperial (PSI).

For Temperature, select between J1939 Default (°C), Metric (°C) and Imperial US (°F).

For Distance & Speed, select between J1939 Default (km, kph, km/L), Imperial (mi., mph, mpg) and Imperial US (mi., mph, mpg).

For Flow Rate, select between J1939 Default (l, l/h), Imperial (gal., gph) and Imperial US (gal., gph).

Press the  button to set your choice.

Service Reminders

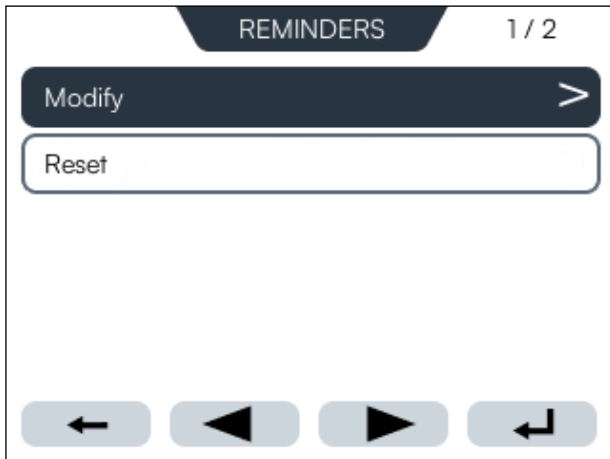

When entering the Service Reminders menu, select between Modify and Reset before changing the parameters shown below.

Shown here is the Modify Reminder screen:

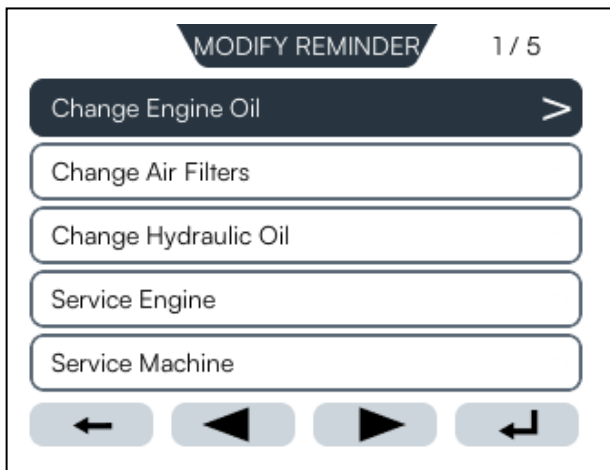

Select the reminder to change. Within each of these choices is an hour scale shown here:



Adjust the number of hours desired (hold the button for faster hour count) until the reminder appears and then press the  button to set your choice. Maximum hours is 65,535.

If RESET is chosen, the choices are to turn the chosen reminder ON or OFF and to reset the timer to what that selection was changed to if it was modified in the previous step.

Menu 2 – Customize Interface

✓QUICK SETUP TIP: Customizing the digital gauges on the S35 is simply done with these steps:

- Enter the menu with the correct passcode.
- Go to Customize Interface, and the gauge you wish to change.
- Scroll through the available choices and select the desired parameter to display in the gauge.
- Save your changes before exiting the menu.
- The new parameter will be displayed in the gauge.

These menus exist to create the custom interface available for the S35.

Show/Hide Features

This menu allows you to choose the features that appear on the S35. Each of the following selections has an **Off** and **On** choice:

- Display 1 Card Screen
- Display 2 Card Screen
- Regeneration Screen
- IO Status Screen
- SenderCAN Plus Screen
- DM2 Screen
- Engine Speed Screen
- Start/Stop Buttons
- Tachometer
- Time and Date

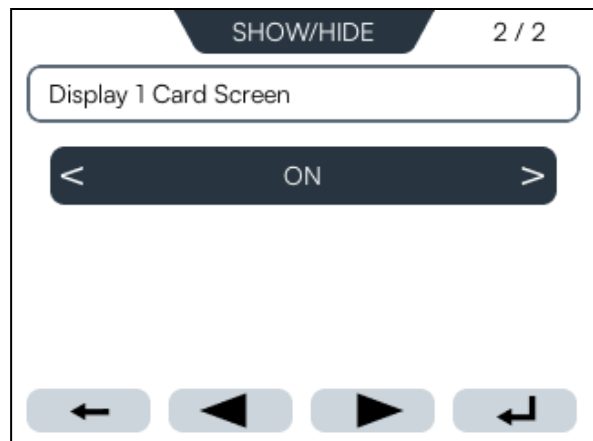

Select the feature, then use the arrows to

choose On or Off, then press the  button to save your choice.

Display 1 Cards, Display 2 Cards and Regen Screen Cards

These three selections are described together because the contents of each match. Each of these display screens provide 4 slots for parameters (two rows, two columns). Select the space to configure and then select the parameter to be displayed there.

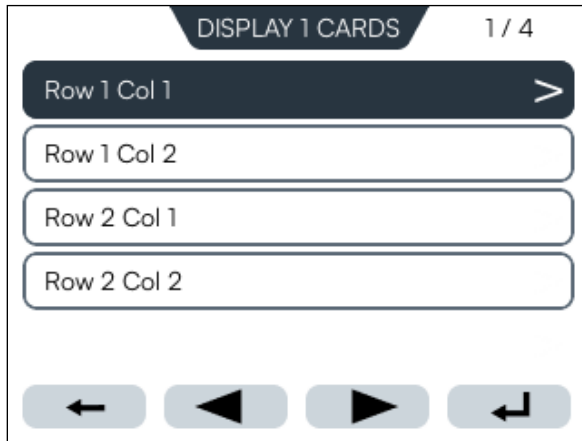

becomes

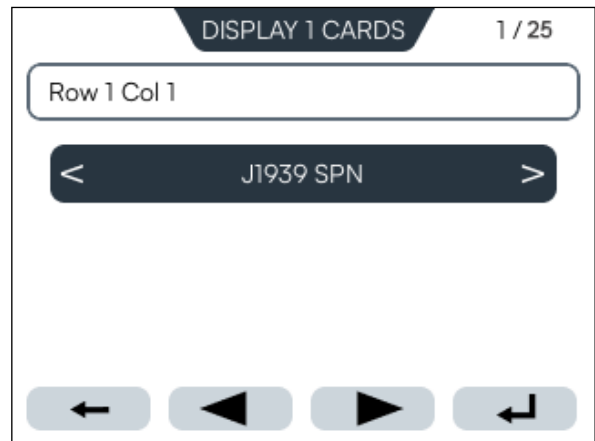

These are the 25 choices for each of these slots.

J1939_SPN	Input 1	Input 2	Frequency_Input Caps
Engine_Hours_Title	Machine_Hours_Title	Battery_Voltage	Current Time
Send_CAN_Input 1	Send_CAN_Input 2	Send_CAN_Input 3	Send_CAN_Input 4
SCPFrequency_Input Caps	User-Defined Param 1	User-Defined Param 2	User-Defined Param 3
User-Defined Param 4	User-Defined Param 5	User-Defined Param 6	User-Defined Param 7
User-Defined Param 8	User-Defined Param 9	User-Defined Param 10	User-Defined Param 11
User-Defined Param 12			

When your selections have been made, press the  button to save your choices.

Tachometer RPM Range

This screen will set the range of the scale on a displayed Tachometer screen.

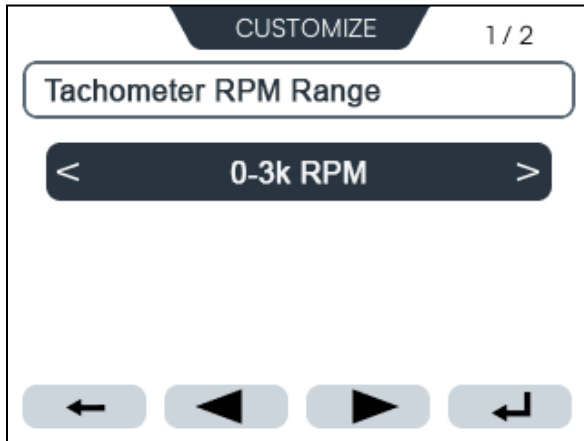

There are two choices for the RPM Range: 0-3k RPM or 0-6k RPM.

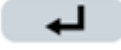
When your selection has been made, press the  button to save your choice.

Menu 3 – Engine

Type

This menu item allows you to choose between two types of Engine: CAN or Mechanical.

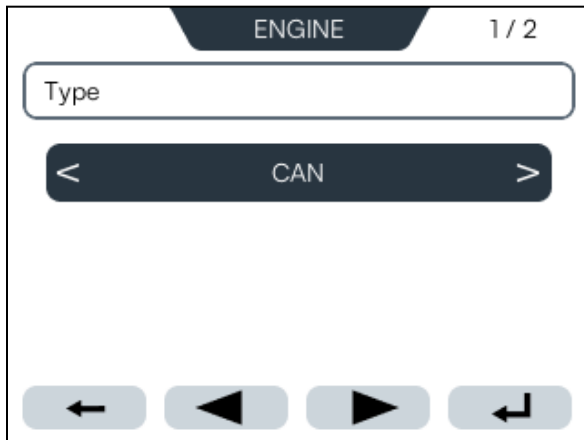

When your selection has been made, press the  button to save your choice.

Manufacturer

This menu item allows you to choose the manufacturer of the engine. The 20 choices are Default, Caterpillar, Cummins, Deutz, Ford, FPT, GM, Hatz, Hyundai Infracore, Isuzu, JCB, John Deere, Kohler, Kubota, Kubota Gas, Perkins, PSI, Scania, Volvo, or Yanmar.

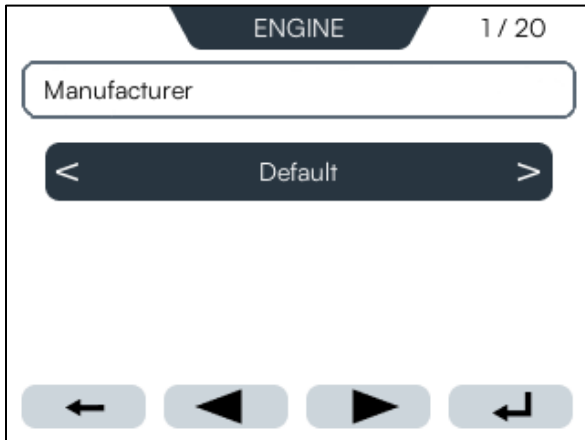

This setting will configure the S35's source address for the selected manufacturer. When left as 'Default', the S35 will use 0xFD.

When your selection has been made, press the



button to save your choice.

ECU Enable Delay

This menu option allows you to configure how long the system waits after sending a start-up command before the ECU is considered active.

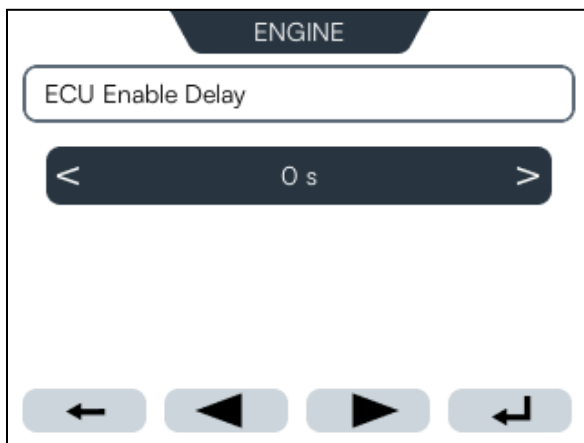

Available choices are in 1 second increments from 0 to 30 seconds.

When your selection has been made, press the



button to save your choice.

Engine Hours

Engine Type	Calculation of Hours
Mechanical	Hours increment when: engine speed > crank disconnect speed (500 rpm).
CAN	The internal engine hours counter is disabled as engine hours are read from J1939 SPN 247.

This menu option allows you to view the current engine's running tally of operation.

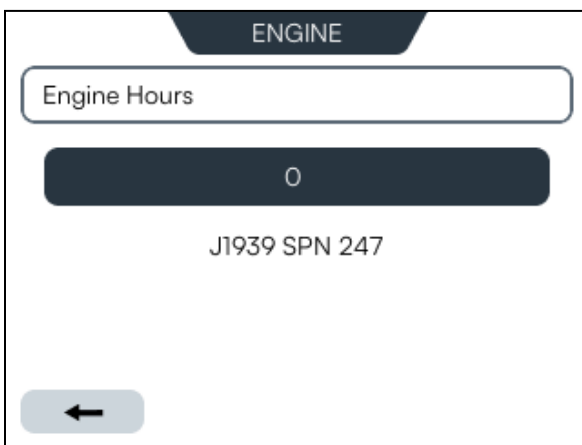

Only the back arrow button is active for this selection.

Machine Hours

Machine hours automatically increase once the rpm threshold is reached, regardless of the selected engine type. This menu selection allows you to view or set Machine Hours and select the RPM Threshold.

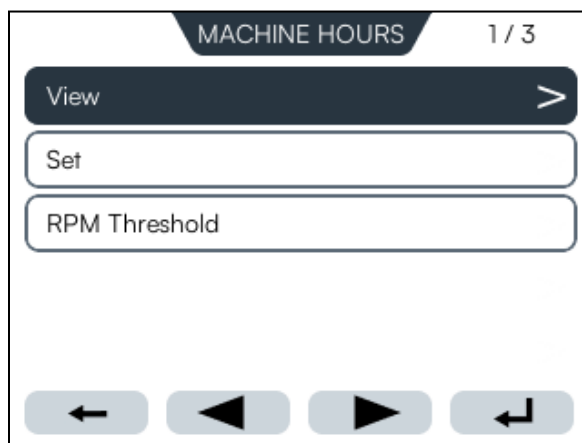

View: Displays the total time the entire machine has been in operation or productive use. Only the back arrow is active for this selection.

Set: Allows you to set the exact hours for the entire machine minus new component hours if some have been replaced

RPM Threshold: allows the setting of the engine speed (measured in revolutions per minute) that acts as a boundary or trigger for certain actions—such as enabling/disabling fuel, protecting the engine from over-revving, or activating monitoring systems. Choose from the range of 500 to 3000 rpm.

When your selection has been made, press the  button to save your choice.

Overspeed Level

This menu option allows you to set the engine speed that will trigger an overspeed warning or turn it off completely. Adjust within the range of 500 to 3000 rpm, or select Off.

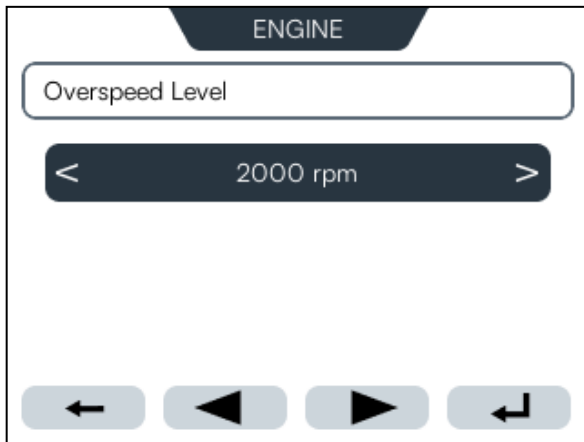

When your selection has been made, press the  button to save your choice.

DM Fault Version

This menu option refers to the version or format of diagnostic messages (DM) used by an ECU under the SAE J1939 protocol. It indicates how fault codes are structured, reported and updated in the system.

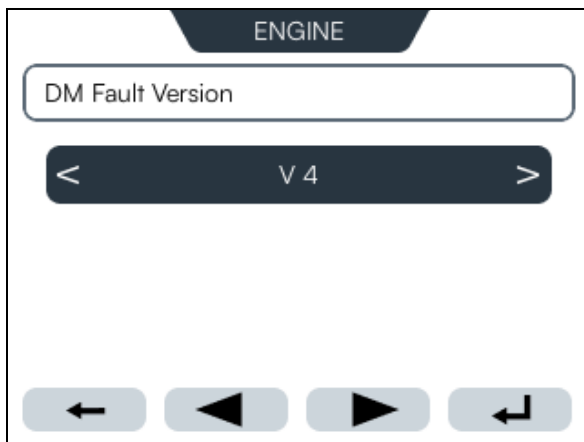

Choices for this selection are V1, V2, V3 or V4.

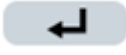
When your selection has been made, press the  button to save your choice.

Menu 4 – Throttle

✓ QUICK SETUP TIP: To enable throttling on the S35, set the Source Address of the Display to match the Engine requirements:

- Enter Menu with correct passcode.
- Go to Communication Setup/Source Address
 - Option 1: manually enter Source Address (common value is 3; will be 253 when set to Off).
 - Option 2: select the Engine manufacturer and the Source Address will automatically be assigned.
- Go to Customize Interface Menu / Engine Speed Presets
 - Choose Idle Speed, Preset 1 and Preset 2.
- Exit and save settings.
- When on the Engine Speed Control page, you can preload any of the set speeds or manually throttle the engine up or down with the Turtle or Rabbit buttons.

This menu set allows the setting of all parameters for the Throttle portion of the engine/machine.

Type

This menu item allows the selection of the type of throttle on the engine. Choices are Use Display Buttons (using the buttons found on the Engine Speed screen to throttle with TSC1) and Analog Input (using the I/O menu to configure your input for throttle control). Please note that if throttling with external buttons you must select Analog Input here and then assign each input to a throttle button (up/down) in the I/O menu.

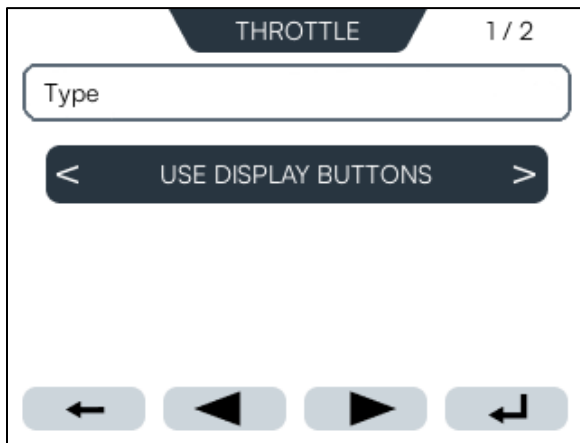



Choices for this selection are Use Display Buttons and Analog Input.

When your selection has been made, press the  button to save your choice.

TSC1 Enable

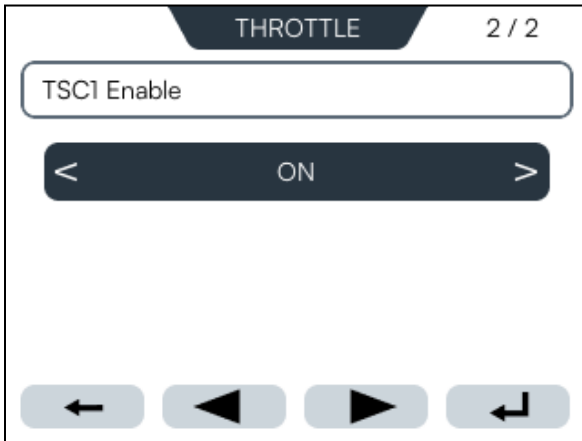
When enabled, the ECU will accept and act on incoming TSC1 messages. This allows external systems to influence engine torque and speed. When disabled, the ECU ignores TSC1 messages. The engine operates only under its own internal control logic. Choices are On and Off.



When your selection has been made, press the  button to save your choice.

Idle Speed

This menu option determines the engine's minimum operating RPM when the throttle is released, and the engine is running without load. It's the baseline speed the ECU maintains to keep the engine stable, preventing stalling, and ensuring smooth operation of accessories. The choices are a range between 500 and 1000 rpm.

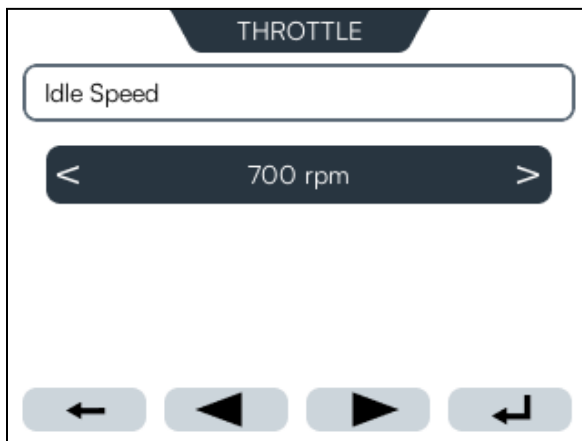

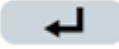
When your selection has been made, press the  button to save your choice.

Max Speed

This menu option defines the highest engine or vehicle speed that the ECU will allow. It acts as a speed limiter or governor, preventing the engine or vehicle from exceeding a programmed maximum rpm or road speed. The choices include a range between 1000 and 6000 rpm.

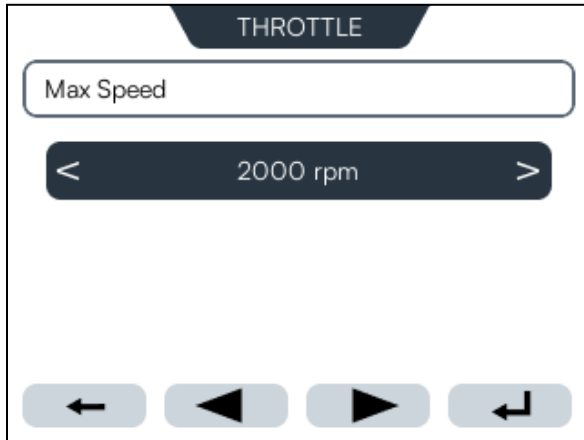

When your selection has been made, press the  button to save your choice.

Engine Speed Presets

This menu option provides predefined rpm values programmed into the ECU that allow the operator or system to quickly select specific, stable engine speeds without manually adjusting the throttle each time.

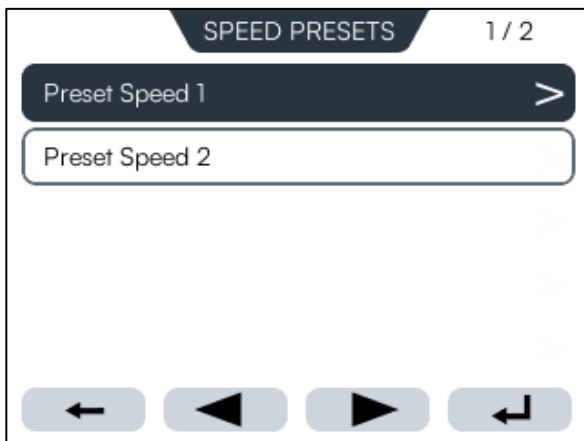

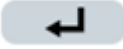

There are two Preset Speeds to establish (1 and 2). For each one, the choices are a range between 0 and 2000 rpm.

When your selection has been made, press the  button to save your choice.

Deadband

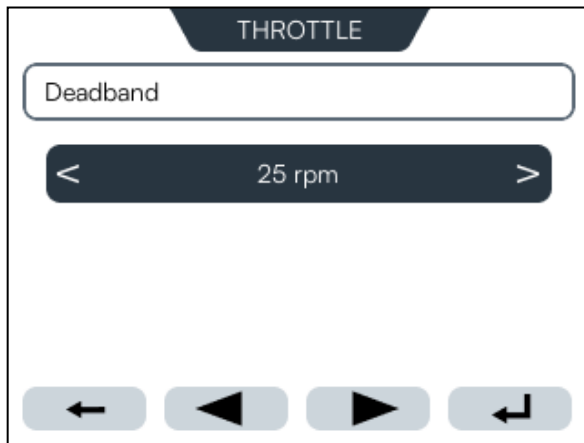
This menu option provides a range of input values where no output action occurs. It's used to prevent constant small corrections (hunting), reduce wear on actuators, and improve system stability (prevents oscillating around the setpoint). The choices are a range between 10 and 100 rpm.



When your selection has been made, press the  button to save your choice.

Menu 5 – IO

- ✓QUICK SETUP TIP: To set up the S35 to measure the engine's fuel level, follow these steps:
- Enter the menu with the correct passcode.
 - Go to the IO menu and select the desired input for fuel.
 - Go to Sender Type and select Fuel Level Sender.
 - Go to Fuel Level Sender options and choose Murphy Fuel Level.
 - Select the Warning Type and Level at which that alarm will emit.
 - Go to Customize Interface, and select the screen and gauge onto which the Fuel level will be displayed.
 - Select the Input you've configured to measure fuel level.
 - Save the changes before exiting.

This menu set serves to configure how the system interacts with external signals – both what it receives (inputs) and what it sends out (outputs). It can be considered the communication hub between the ECU or controller and the outside world.

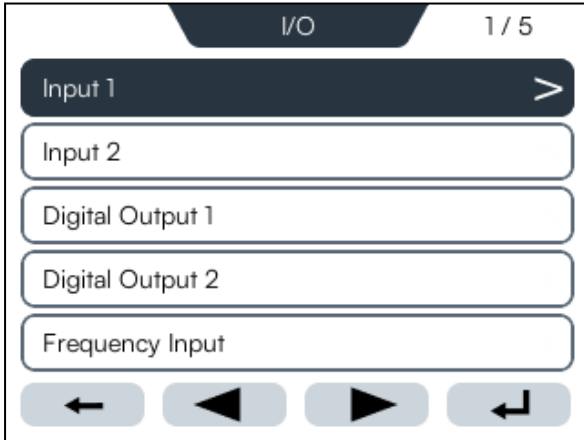

Choices for this level are Input 1, Input 2, Digital Output 1, Digital Output 2, Frequency Input and SenderCAN Plus.

When your selection has been made, press the  button to save your choice or enter that menu.

Input 1 and Input 2

These two menu items allow the same choices to designate the Sender Type and Warning/Alarm inputs.

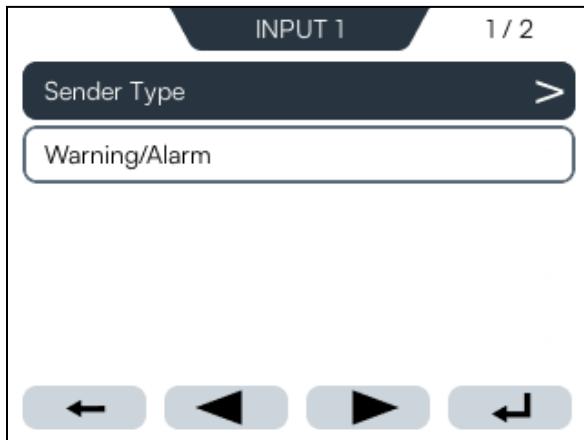

Choices for Sender Type include None, Temperature Sender, Pressure Sender, Fuel Level Sender, Custom Curve Resistive, Custom Curve 4-20mA, Custom Curve 0-5V, Digital Resistive, Digital 0-5V, Analog Throttle (Resistive), Analog Throttle (0-5V), Throttle Button Up and Throttle Button Down.

Choices for Warning/Alarm include Off, High Warning, Low Warning, High Shutdown and Low Shutdown.

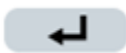
When your selection has been made, press the  button to save your choice or enter that menu.

Digital Outputs 1 and 2

These menu selections configure which external devices or functions the controller will activate through its digital outputs. This ensures the right devices respond to the right signals.

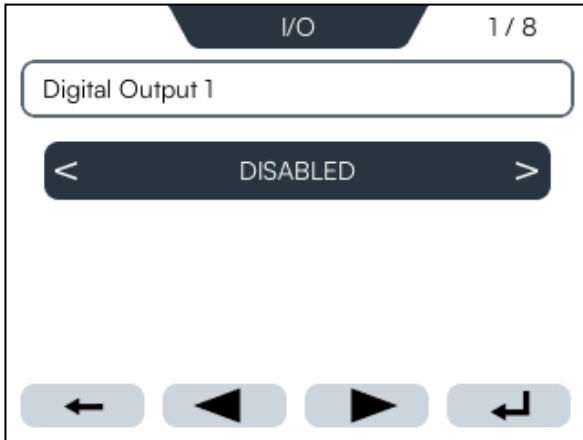

The choices available for both Outputs 1 and 2 include Disabled, ECU Enable, Overspeed, Engine Specific Alarm, Any Alarm Active, Crank, Engine Running, DM1 Red Stop Lamp, and DM1 Amber Warning Lamp.

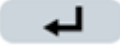
When your selection has been made, press the  button to save your choice or enter that menu.

Frequency Input

This menu defines how the controller interprets incoming signals that are frequency-based. This allows you to configure which input channel is assigned to a frequency-based sensor. Choices for this menu include Type and Warning/Alarm.

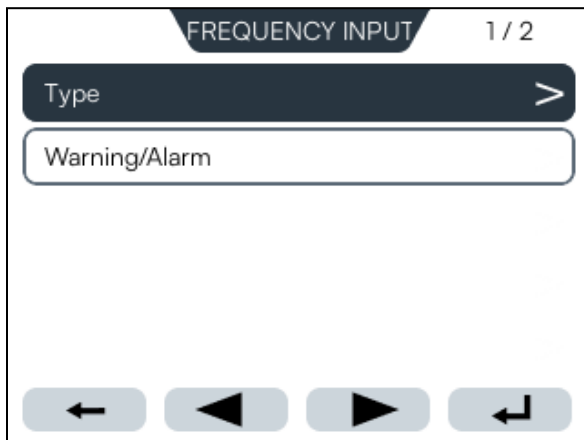

Choices for Type include Off, Engine Speed and Vehicle Speed.

Choices for Warning/Alarm include Off, High Warning, Low Warning, High Shutdown and Low Shutdown.

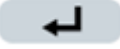
When your selection has been made, press the  button to save your choice or enter that menu.

SenderCAN® Plus

This menu selection allows the simplification of how sensors, switches and other inputs are converted into J1939 CAN bus messages, making it easier to integrate rugged equipment with modern electronic control systems. The choices available in this menu set include

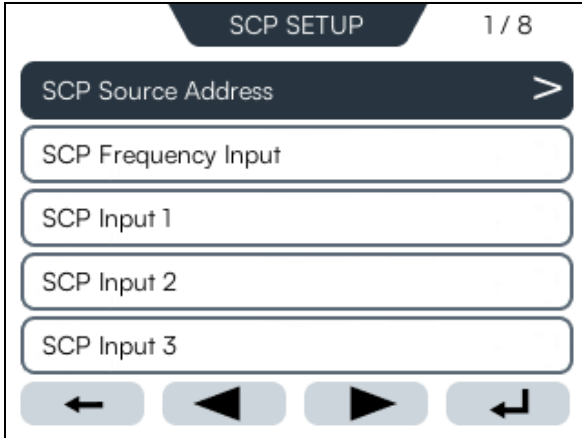

(1) SCP Source Address choices are Off, 1 through 253.

(2) SCP Frequency Input choices include Type (Off, Engine Speed and Vehicle Speed) and Warning/Alarm (Off, High Warning, Low Warning, High Shutdown and Low Shutdown).

(3) SCP Input 1 through 4 choices include Sender Type (None, Temperature Sender, Pressure Sender, Fuel Level Sender, Custom Curve Resistive, Custom Curve 4-20mA, Custom Curve 0-5V, Digital Resistive, Digital 0-5V, Analog Throttle (Resistive), Analog Throttle (0-5V), Throttle Button Up, Throttle Button Down) and Warning/Alarm Type (Off, High Warning, Low Warning, High Shutdown, Low Shutdown).

(4) SCP Digital Output 01 and 02 (low) choices include Disabled, ECU Enable, Overspeed, Engine Specific Alarm, Any Alarm Active, Crank, Engine Running, DM1 Red Stop Lamp, DM1 Amber Warning Lamp, Engine Speed Increase and Engine Speed Decrease.

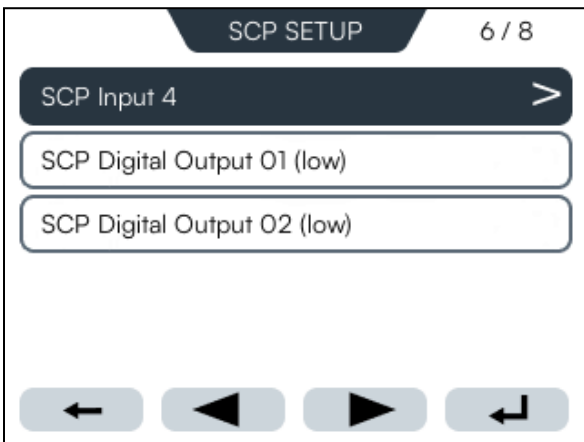

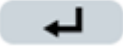
When your selection has been made, press the  button to save your choice or enter that menu.

Menu 6 - System

This menu set provides the methods to review the software version, set the Time and Date, configure all passcodes and restore all defaults.

Software Version

This menu option simply displays the software version.

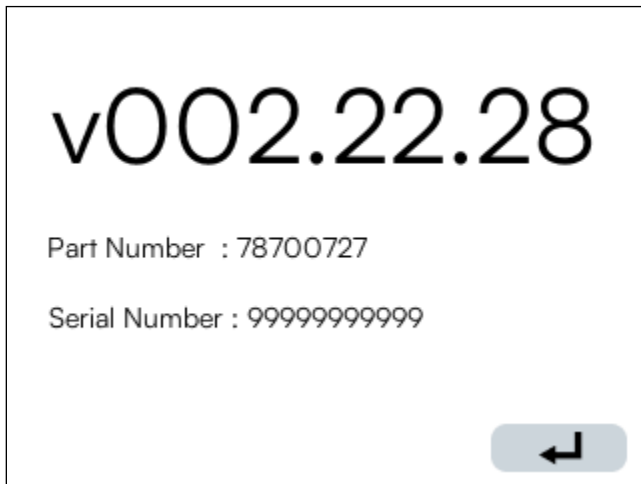

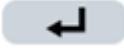
Press the  button to return to the menu.

Time and Date

This menu allows you to change the time and date.

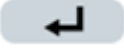

To change the sections, use the right arrow (to increase) or left arrow (to decrease) to change the area that is colored green. Press the  button to move the highlighting to the next position and repeat the number changes.

Note that the format is Day, Month, Year for the date.

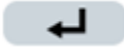
When your selection has been made, press the  button to save your choice or enter that menu.

Configure Passcodes

This system uses three passcode levels – Low, Medium and High. Each level unlocks more menu options and settings, with higher levels giving greater control. Low gives basic access, Medium unlocks more settings, and High gives full control. If the user sets the High level passcode to “0000”, then the passcode screen will be skipped and the menu will display every time the Menu button is pressed.

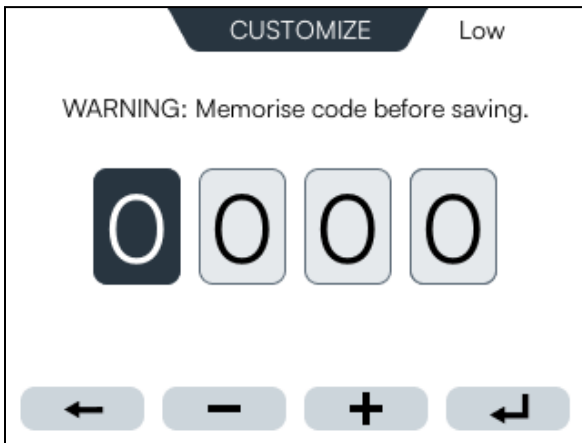

Note: Ensure the passcode is memorized before saving it.

Use the + and/or – buttons to adjust the highlighted number.

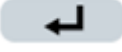
Use the  button to progress to the next number and finally to enter the new passcode.

Restore All Defaults

This menu setting will reset the S35 back to its original factory settings, erasing all custom changes.

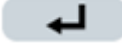
Note: Be sure this is what you desire when you select this menu item and press the  button. The Restore function is immediate and does NOT ask a second time before restoring the defaults. The next screen displayed will state “Default Settings Restored.”

Menu 7 - Communication Setup

This section allows the customer to establish how the controller exchanges information with other devices on the network. By configuring the controller and engine source addresses, the user defines unique identifiers for each unit on the CAN bus. The CAN baud rate and termination resistor settings ensure proper signal timing and network stability, while the MODBUS setup provides options for integrating with external systems that use the MODBUS protocol. Together, these controls give the customer the ability to tailor communication parameters for reliable data flow and seamless interoperability across connected equipment.

Controller Source Address

A Controller Source Address is the unique identifier determined by the manufacturer selected in the Engine menu. Assigned to a controller on a CAN bus network, it informs other devices where messages are coming from and ensures that communication across the network is organized and conflict-free. Changing this value will override the preset address used for the selected manufacturer.

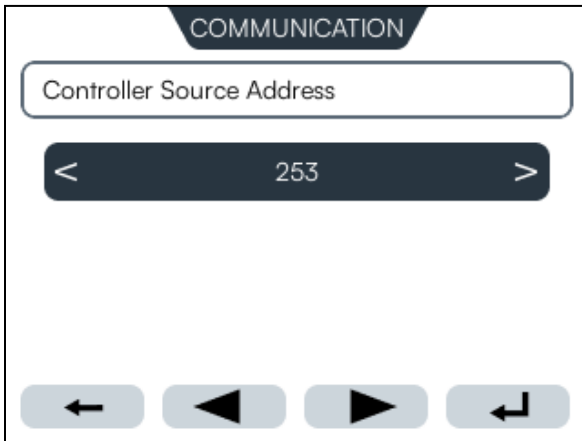

Choices for this setting are Engine Manufacturer Default, and numbers 1 through 253.

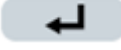
When your selection has been made, press the  button to save your choice or enter that menu.

Engine Source Address

An Engine Source Address is the unique identifier assigned to the engine's ECU on a CAN bus network that tells other devices on the network which messages are coming from the engine.

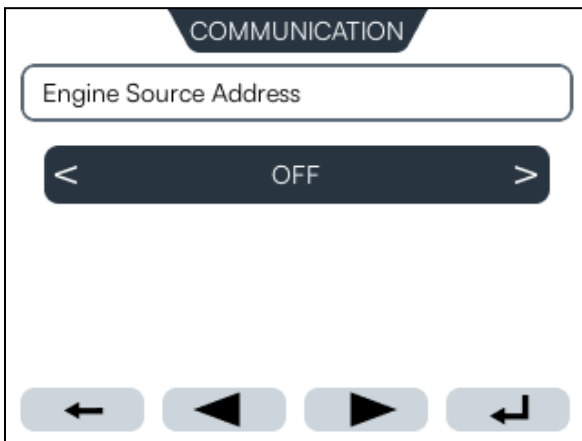

The default for this menu item is 0, but it can be set to any value in the range of 0—254.

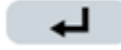
When your selection has been made, press the  button to save your choice or enter that menu.

CAN Baud Rate

The CAN Baud Rate is the speed at which data is transmitted across a Controller Area Network (CAN bus), measured in bits per second (bps). It defines how quickly messages move between devices like the engine ECU, controllers and displays.

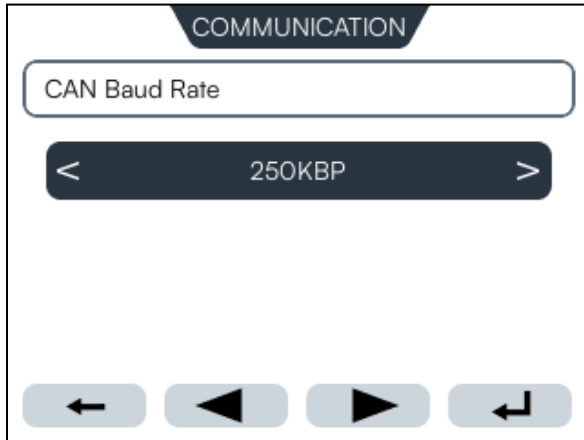

Choices for this menu item are 125KB, 250KB, 500KB and 1MB.

When your selection has been made, press the  button to save your choice or enter that menu.

CAN Termination Resistor

A CAN Termination Resistor is a critical component in a CAN bus that ensures reliable communication by stabilizing the electrical signals traveling along the bus.

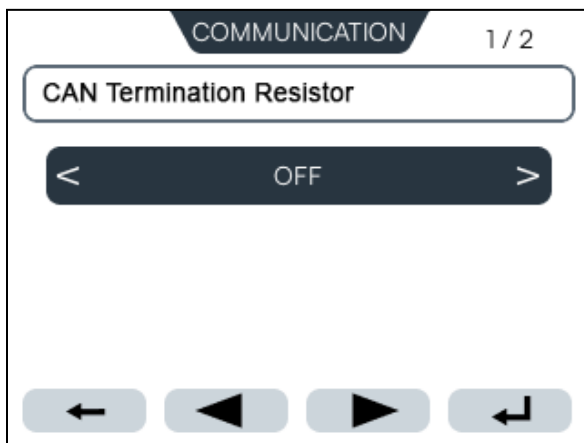

Choices for this menu item are Off and On.

When your selection has been made, press the  button to save your choice or enter that menu.

MODBUS Setup

This section is used to configure how the controller communicates using the MODBUS protocol.

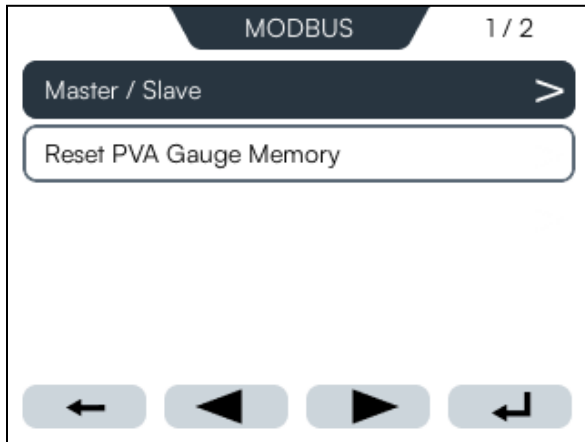

Choices for Master / Slave are Master and Slave.

When selecting Reset PVA Gauge Memory, the display will present the  button to confirm that the PVA Gauge Memory will be reset. Pressing that button will force the display to search for PVA Gauges to reset.

Once the reset is complete, this screen will appear:

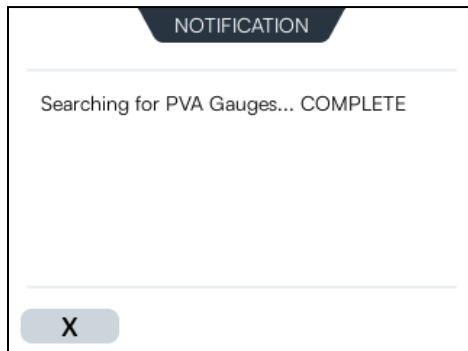

Press the  button to close this screen.

Final Screen – Notification

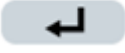
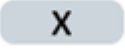
After making changes to the menu settings, backing out of the menu screens will produce the following screen: If yes, press the  button. If no, press the  button.

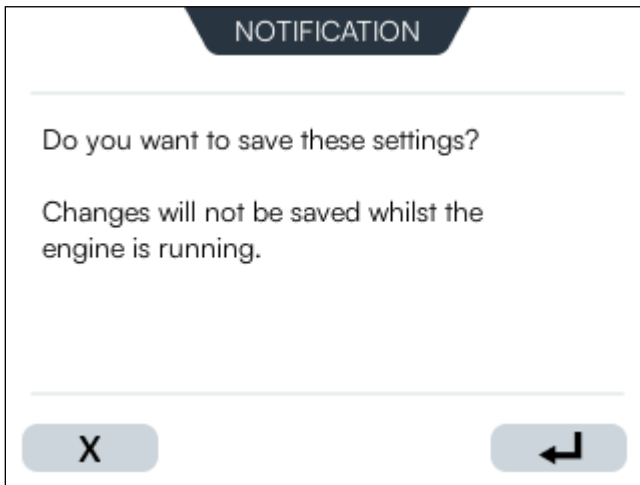

If the engine is running then it must be stopped before changes can be saved. It is a safety hazard to change settings while the engine is in operation.

PC Configuration Tool

All settings available on the display (and certain settings not accessible through the display's menus) can also be configured using the PC Configurator tool.

These options are provided exclusively in the PC tool for convenience—such as when entering or customizing text, where data entry is easier using a computer.

The additional settings available when using the PC tool are described in the following sections.

Display Tab

All options, apart from 'Set Logo', can also be configured on the display as described in the manual previously.

Set Logo – Selects a logo to be displayed on the splash screen. The tool will convert the selected image to a 24-bit bitmap file with a size of 200px(width) by 100px (height).

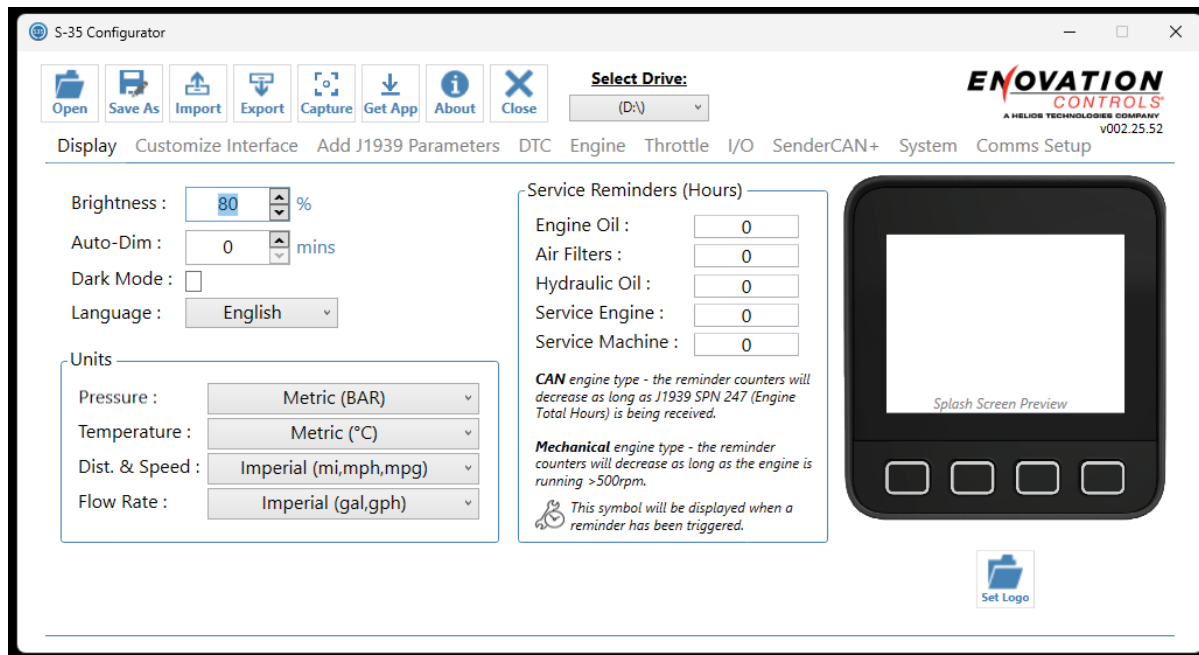

Customize Interface Tab

All options, apart from the I/O screen custom names, can also be configured on the display as described in the manual previously.

I/O screen display names – Customize the names of the analog inputs which are displayed on the IO status screen.

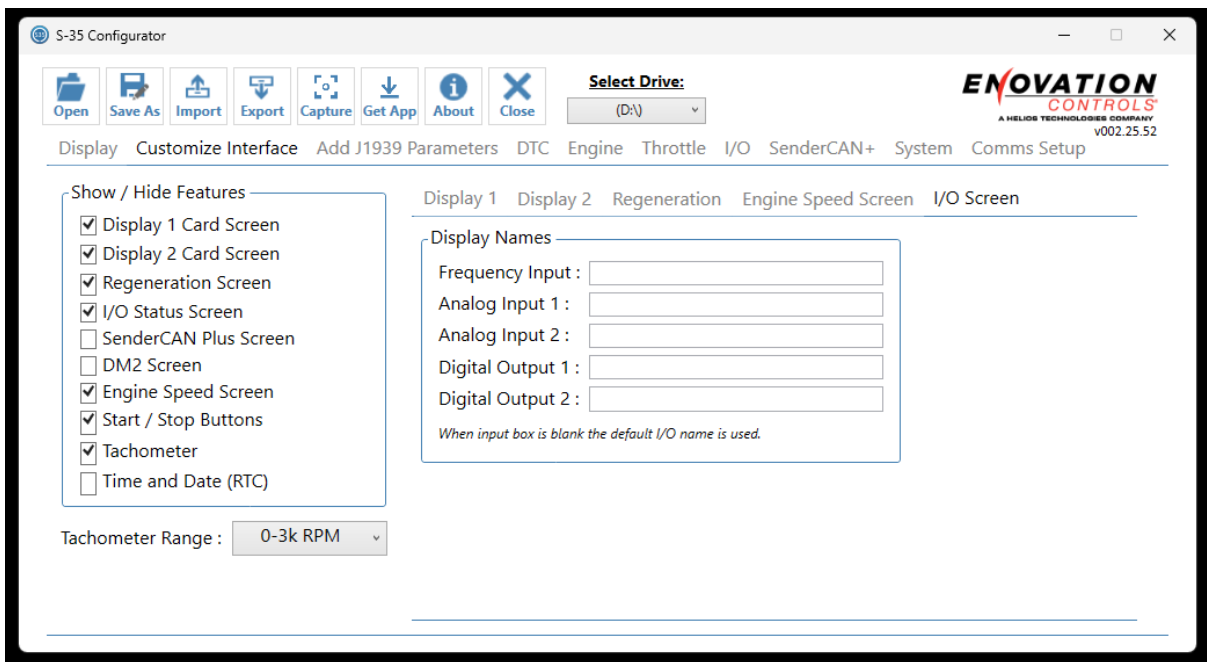
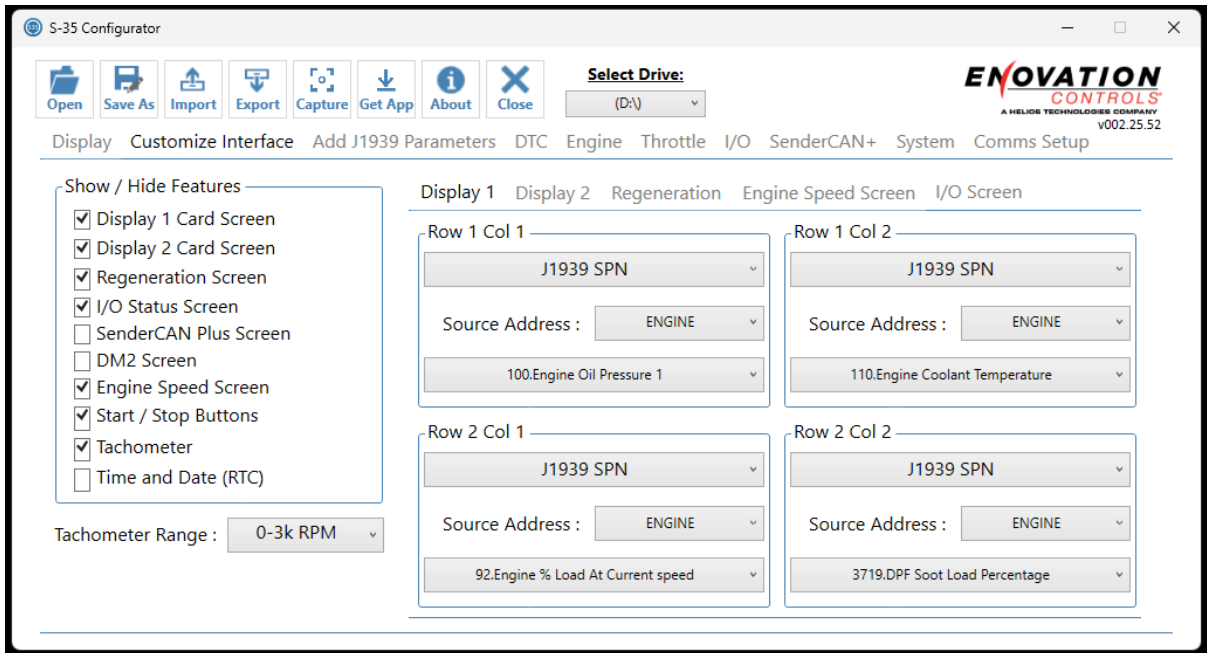

Add J1939 Parameters Tab

All the settings on this tab can only be set using the PC configurator tool, not on the display. Add up to 12 custom J1939 parameters.

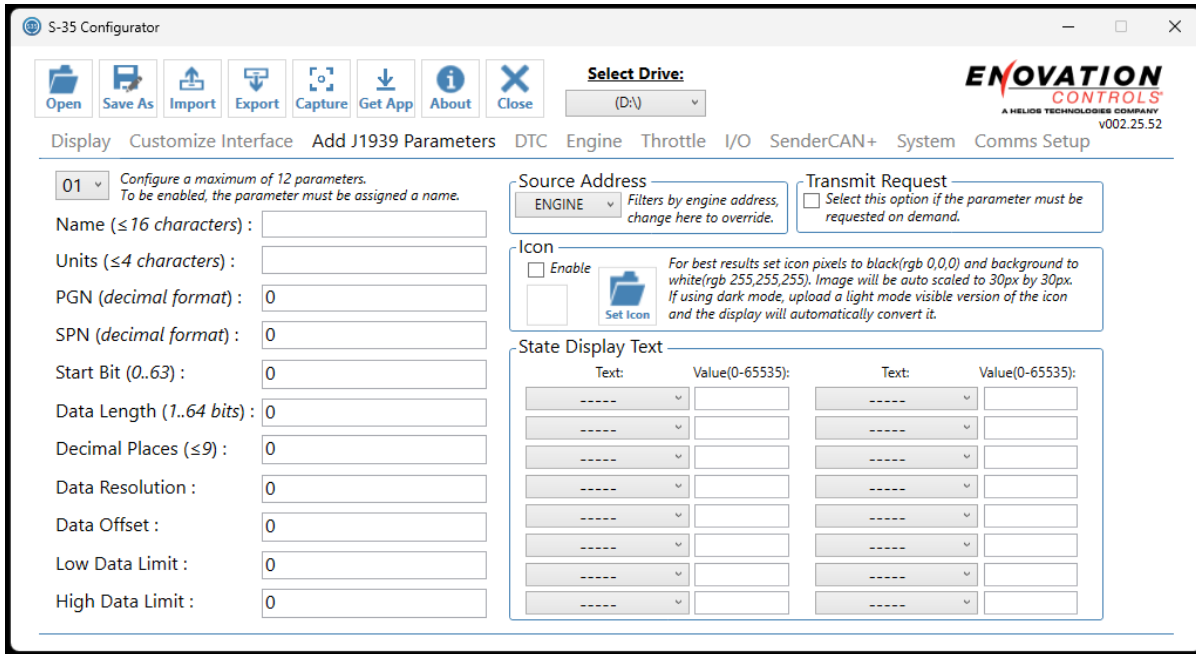

DTC Tab

All the settings on this tab can only be set using the PC configurator tool, not on the display.

Drop list – add up to 10 SPN/FMI pairs which will be ignored if received over CAN.

Custom Diagnostic Message – customize the description of the diagnostic message which is displayed when the defined SPN/FMI pair is received over CAN.

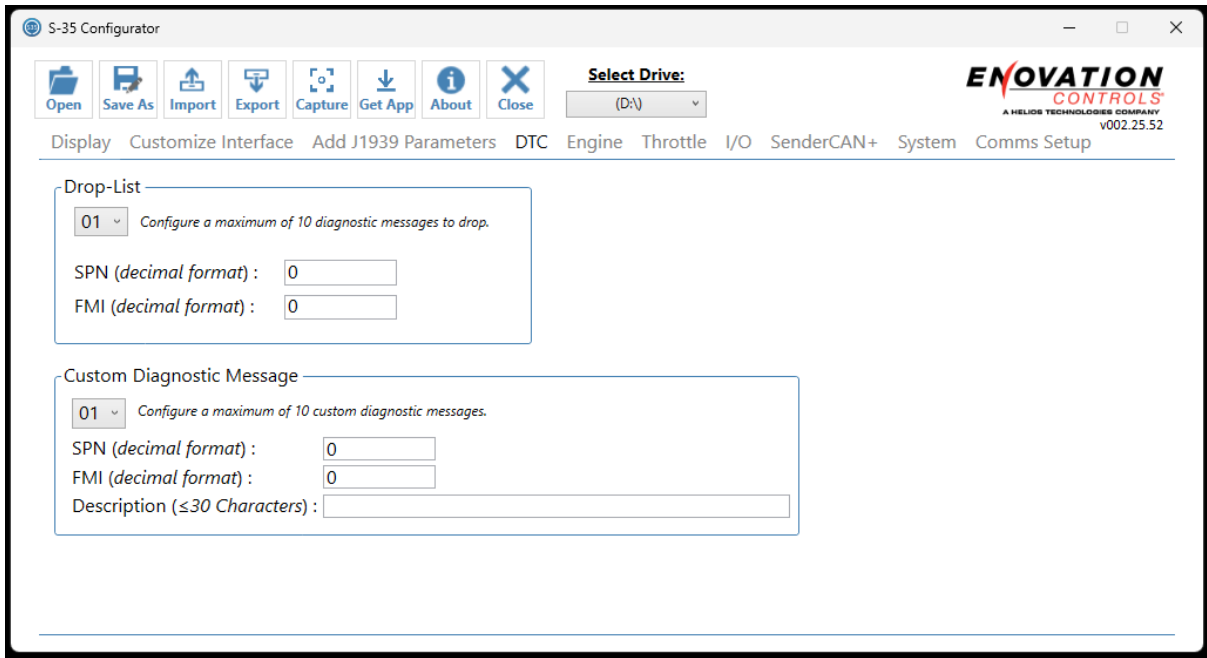

In order to consistently bring you the highest quality, full-featured products, we reserve the right to change our specifications and designs at any time. MURPHY products and the Murphy logo are registered and/or common law trademarks of Enovation Controls, LLC. This document, including textual matter and illustrations, is copyright protected by Enovation Controls, LLC, with all rights reserved. (c) 2025 Enovation Controls, LLC. A copy of the warranty may be viewed or printed by going to www.enovationcontrols.com/warranty

ENOVIATION CONTROLS CORPORATE HEADQUARTERS
5311 S 122ND EAST AVENUE
TULSA, OK 74146

ENOVIATION CONTROLS LTD. – UNITED KINGDOM
CHURCH ROAD LAVERSTOCK
SALISBURY SP1 1QZ UK

SUN MURPHY INTERNATIONAL TRADING (SHANGHAI) CO., LTD
B15 ROOM, 6# BUILDING, 351 SIZHUAN ROAD
SONGJIANG DISTRICT, SHANGHAI 201601, CHINA

ENOVIATION CONTROLS INDIA PVT. LTD.
PLOT NO. 146, SECTOR 10, PCNTDA
BHOSARI, PIMPRI CHINCHWAD
PUNE - 411026
MAHARASHTRA, INDIA

U.S. SALES & SUPPORT

PHONE: 918 317 4100
EMAIL: ECSALES@ENOVIATIONCONTROLS.COM
WWW.ENOVIATIONCONTROLS.COM

CONTACT US



INTERNATIONAL SALES & SUPPORT

EUROPE, MIDDLE EAST, AFRICA
PHONE: +44 1722 410055
EMAIL: EMEASALES@ENOVIATIONCONTROLS.COM

CHINA
PHONE: +86 21 6237 5885
EMAIL: APACSALES@ENOVIATIONCONTROLS.COM

INDIA
PHONE: +91 91581 37633
EMAIL: INDIASALES@ENOVIATIONCONTROLS.COM



FM 28221 (Tulsa, OK - USA)
FM 29422 (UK)



1022QAP07 (India)