



Intelligent **X**ansion Series

HCPDM Reference Manual

Warranty - A limited warranty on materials and workmanship is given with this Enovation Controls product.
A copy of the warranty may be viewed or printed by going to www.enovationcontrols.com/warranty



BEFORE INSTALLING THIS ENOVATION CONTROLS PRODUCT:

Read and follow all instructions.

Please contact Enovation Controls immediately if you have any questions.

CONTENTS

1	INTRODUCTION	3
1.1	OVERVIEW	3
1.2	DESCRIPTION	5
1.3	NOTATION CONVENTIONS USED IN THE MANUAL.....	6
2	INSTALLATION	7
2.1	MOUNTING ORIENTATION	7
2.2	DIMENSIONS	8
2.3	CIRCUIT PROTECTION	9
2.4	RECOMMENDED WIRING PRACTICES.....	9
3	ELECTRICAL CONNECTIONS.....	12
3.1	CONNECTORS - AND +	12
3.2	CONNECTOR E	13
3.3	CONNECTOR A.....	14
3.4	CONNECTOR B.....	15
3.5	CONNECTOR C.....	16
3.6	CONNECTOR D	17
4	COMMUNICATION	18
4.1	OVERVIEW	18
4.1.1	<i>Source Address</i>	18
4.1.2	<i>Loss of Communication</i>	19
4.1.3	<i>Output Modes</i>	19
4.1.4	<i>Special Methods of Operation</i>	19
4.1.4.1	Power on Reset (POR).....	19
4.1.4.2	Local Source Control.....	19
4.2	NAMING AND NUMBERING CONVENTIONS.....	20
4.3	CONFIGURING	21
4.3.1	<i>Configure Motor Model & Output Function</i>	22
4.3.1.1	Configuration Identifier	23
4.3.1.2	Output Channel	23
4.3.1.3	Soft-Start Step Size	23
4.3.1.4	Motor/Lamp Mode.....	24
4.3.1.5	Loss of Communication	25
4.3.1.6	Command Mode.....	25
4.3.1.7	POR Command.....	25
4.3.1.8	POR Enable	27
4.3.1.9	Command Type.....	27
4.3.1.10	Motor Braking.....	27
4.3.1.11	LSC Digital Input.....	28
4.3.1.12	Calibration Time	28
4.3.1.13	Response.....	28
4.3.2	<i>Configure Output Channels</i>	29
4.3.2.1	Output Channel Group Identifier	30
4.3.2.1	Current Limit.....	30
4.3.2.3	Feedback Type	31
4.3.2.4	Automatic Reset	31
4.3.2.5	High-Side or H-Bridge	32
4.3.3	<i>Configuring Analog Input Channels</i>	32
4.3.3.1	Message Identifier	33
4.3.3.2	Analog Input Channel Configuration	33

4.3.4	<i>Configuring MISC</i>	33
4.3.4.1	Message Identifier	34
4.3.4.2	Sensor Supply Enable.....	34
4.3.4.3	Ignition Enable	34
4.3.5	<i>Configuring Position</i>	34
4.3.5.1	Message Identifier	35
4.3.5.2	Output Channel #.....	35
4.3.5.3	Position Hysteresis.....	35
4.3.5.4	Stalled resistance	36
4.3.5.5	Gain.....	36
4.3.5.6	Position	36
4.4	COMMANDING	37
4.4.1	<i>Command Output Channels</i>	37
4.4.1.1	Output Command Identifier	38
4.4.1.2	Command	38
4.4.1.3	Enable	39
4.4.1.4	Module Transmit Rate.....	39
4.4.2	<i>Command High Side Output</i>	40
4.4.2.1	Output Command Identifier	41
4.4.2.2	HS Out CH command	41
4.5	FEEDBACK AND DIAGNOSTICS	41
4.5.1	<i>Analog Inputs Feedback</i>	42
4.5.1.1	Feedback and Diagnostics Identifier	43
4.5.1.2	Analog Inputs.....	43
4.5.2	<i>Diagnostics Outputs 1 - 8</i>	44
4.5.2.1	Output Diagnostic.....	45
4.5.3	<i>HCPDM Status</i>	45
4.5.3.1	Power Supply Status	46
4.5.3.2	Software Revision	46
4.5.3.3	5V Supply Status	47
4.5.3.4	Battery Voltage	47
4.5.4	<i>Feedback</i>	48
4.5.4.1	Current, Power, Position or Rate Feedback	49
4.5.5	<i>Motor Model Handshake</i>	49
4.5.6	<i>Output Configuration Handshake</i>	50
4.6	EXAMPLE MESSAGES	53
4.6.1	<i>Arbitration Field</i>	53
4.7	EXAMPLE PSEUDO CODE.....	54
4.7.1	<i>Configure and Verify Outputs</i>	54
4.7.2	<i>Command Outputs</i>	54
4.7.3	<i>Read Diagnostics</i>	54
5	TROUBLESHOOTING	55
5.1	OUTPUT DOES NOT RESPOND	55
5.2	HCPDM DOES NOT FUNCTION	55
6	SPECIFICATIONS	56
7	CONDENSED MESSAGE & BYTE DEFINITION	59
8	CONDENSED MESSAGE VARIABLE DEFINITION	60
9	POWER ON RESET KEY	61

1 Introduction

1.1 Overview

Enovation Control's Intelligent Xpansion™ High Current Power Distribution Module (HCPDM) expands CAN bus networks and replaces existing fuse and relay boxes with more reliable, solid-state switches that can directly drive lights, cooling fans, wiper motors and directional DC motors.



Each of the 8 HCPDM outputs can switch or proportionally drive 40A loads and feature built-in over-current detection and shutdown capability. Outputs can be paired to run up to four electric motors with H-bridge direction control.

Two additional digital (100 mA) outputs are available for driving relay coils or LEDs and are capable of remaining active through an engine crank cycle. Additionally, six configurable inputs are available with a switchable 5V sensor supply.

Wiring length is reduced and costs are cut by remotely locating the PDM module near sensors and loads. Then the I/O is multiplexed using a CAN bus network, which allows engineers to greatly simplify harness design for ease of installation and improved reliability.

For applications not requiring a CAN bus, the inputs can directly trigger outputs, so there is no need for a separate microcontroller.

The enclosure is fully sealed to withstand wash-down and dust.

The unit is robust in design and can be mounted nearly anywhere on a vehicle.

The HCPDM is an advanced CAN-based I/O module with built-in fault detection for directly driving high current loads such as work lights, DC motors and actuators, heaters, subcircuits and many other demanding devices. It allows for the flexible I/O extension of CAN bus systems using the SAE J1939 protocol or stand-alone operation by replacing traditional switch-activated fuse and relay boxes.

The HCPDM features a robust e-coated aluminum housing and can operate in nominal 12V systems. The solid construction and robust enclosure facilitate mounting anywhere on the vehicle.

The HCPDM provides a novel alternative to current relay/fuse-based solutions. The PDM is fully sealed and has no mechanical parts. It eliminates relays and fuses on the outputs so outputs can be switched ON/OFF or driven proportionally. Output status can be monitored for improved diagnostics, while analog and digital input devices are easily connected and their signals accessed via CAN messages.

The HCPDM uses a combination of a single field-proven Deutsch DT16-18 way connector for inputs, sensor supply, and CAN; 4 AMP MCP9.5 connectors for high current outputs; and threaded studs for the power and ground connections. This optimized arrangement ensures superior performance in the most adverse environments. In addition, the 8 fully protected solid-state outputs have the capacity to handle high current loads up to 40A each continuously (maximum simultaneous current is limited to 200A).

The housing design simplifies mounting and eases harness installation through reduced wiring. The unit is physically designed to adequately dissipate the heat associated with powering very large loads. An innovative I/O structure facilitates monitoring and enables remote configuration, allowing for quick adaptation in numerous mobile applications.

This robust unit is intended for use in adverse conditions where reliable operation is crucial, extreme temperature variations are common, high shock and vibration levels exist and electromagnetic interference (EMI) is normal.

The HCPDM is designed for mobile equipment use and is configurable using the SAE J1939 Group A Proprietary message construct. It is also suitable for use in unprotected outdoor applications such as stationary machinery or remote DC powered equipment.

1.2 Description

The HCPDM is a robust, solid state, fully sealed unit and is designed for off-highway mobile equipment and other demanding industrial applications.

It features 6 configurable inputs, 8 high-current (40 A) high-side outputs, and 2 100 mA outputs for driving small loads such as relays or LEDs. The low current outputs are functional during engine crank. The unit also features a fully protected 5V sensor supply capable of driving 200 mA.

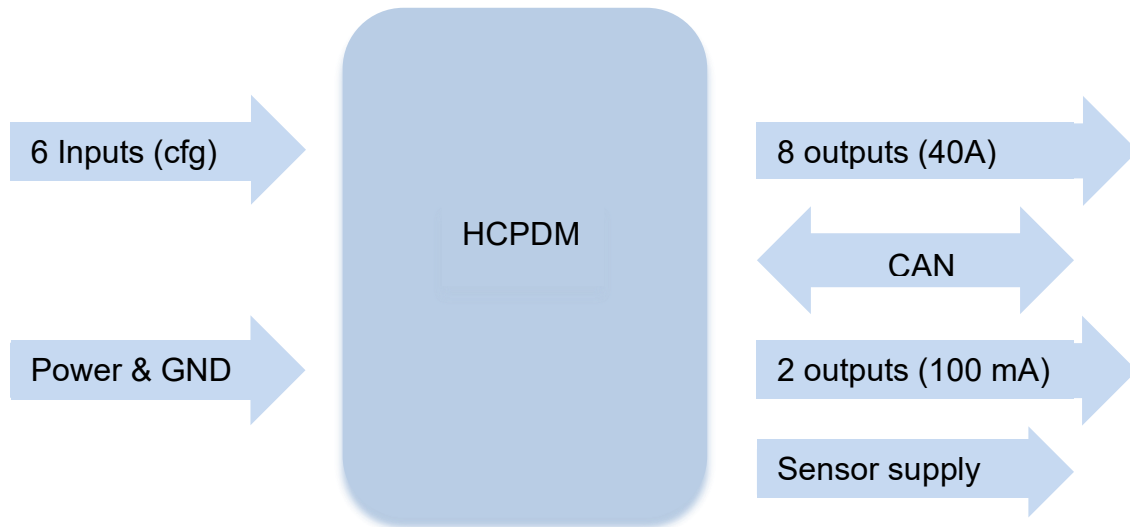

The 8 high-current outputs can be configured as H-Bridge pairs or individually as high side digital outputs. The outputs also can be configured for pulse-width-modulated (PWM) operation. All outputs feature a 500 Hz PWM frequency with better than 1 percent duty cycle resolution; these can be used to proportionally drive outputs.

Each output channel incorporates output-overload-shutdown configurable in 2.5A increments, diagnostic indication of short circuit, overload (based on shutdown value) and open circuit. An indication is given when the entire module has total current overload. The regulated 5-volt output is monitored, and two bits indicate diagnostic status for an overload, short circuit or short-to-supply.

The PDM uses CAN messages to receive configuration and control messages as well as send feedback and diagnostics using J1939 Proprietary Group A constructs.

1.3 Notation Conventions Used in the Manual

This document features Adobe Reader bookmarks to quickly jump between sections. Additionally, [blue-colored hyperlinks](#) are used throughout the manual to allow easy navigation between the various CAN messages.

HCPDM Reference Manual Test.pdf	
1 Introduction	
1.1 Overview	
1.2 Description	
1.3 Notation Conventions Used in the M...	
2 Installation	
2.1 Mounting Orientation	
2.2 Dimensions	
2.3 Circuit Protection	
2.4 Recommended Wiring Practices	
3 Electrical Connections	
3.1 Connectors J2 and J7	
3.2 Connector J1	
3.3 Connector J3 A	
3.4 Connector J3 B	
3.5 Connector J3 C	
3.6 Connector J3 D	
4 Communication	
4.1 Overview	
4.2 Naming and Numbering Conventions	
4.3 Configuring	
4.4 Commanding	
4.5 Feedback and Diagnostics	
4.6 Example Messages	
4.7 Example Pseudo Code	
5 Troubleshooting	
6 Specifications	
7 Condensed Message & Byte Definition	

CONTENTS	
1 INTRODUCTION	3
1.1 OVERVIEW	3
1.2 DESCRIPTION	5
1.3 NOTATION CONVENTIONS USED IN THE MANUAL	6
2 INSTALLATION	7
2.1 MOUNTING ORIENTATION	7
2.2 DIMENSIONS	8
2.3 CIRCUIT PROTECTION	9
2.4 RECOMMENDED WIRING PRACTICES	9
3 ELECTRICAL CONNECTIONS	12
3.1 CONNECTORS J2 AND J7	12
3.2 CONNECTOR J1	13
3.3 CONNECTOR J3 A	14
3.4 CONNECTOR J3 B	15
3.5 CONNECTOR J3 C	16
3.6 CONNECTOR J3 D	17
4 COMMUNICATION	18
4.1 OVERVIEW	18
4.1.1 Source Address	18
4.1.2 Loss of Communication	19
4.1.3 Output Modes	20
4.1.4 Special Methods of Operation	20
4.1.4.1 Power on Reset (POR)	20
4.1.4.2 Local Source Control	20
4.2 NAMING AND NUMBERING CONVENTIONS	21
4.3 CONFIGURING	23
4.3.1 Configure Motor Model & Output Function	24
4.3.1.1 Configuration Identifier	25
4.3.1.2 Output Channel	25
4.3.1.3 Soft-Start Step Size	25
4.3.1.4 Motor/Lamp Mode	27
4.3.1.5 Loss of Communication	27

2 Installation

2.1 Mounting Orientation

The HCPDM should be mounted on a vertical surface with either A – D connectors facing up or down. Mounting the unit with A – D connectors facing right or left does not provide optimal cooling of the unit. Secure the module with either 6 mm or 1/4 in. diameter fasteners.

IMPORTANT: The harness should have a drip loop(s) to allow water to run off the wires.

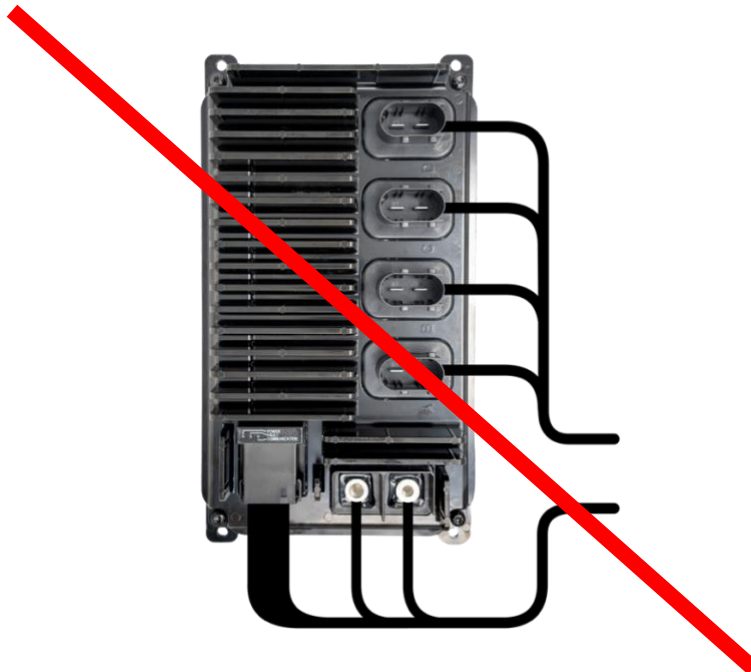
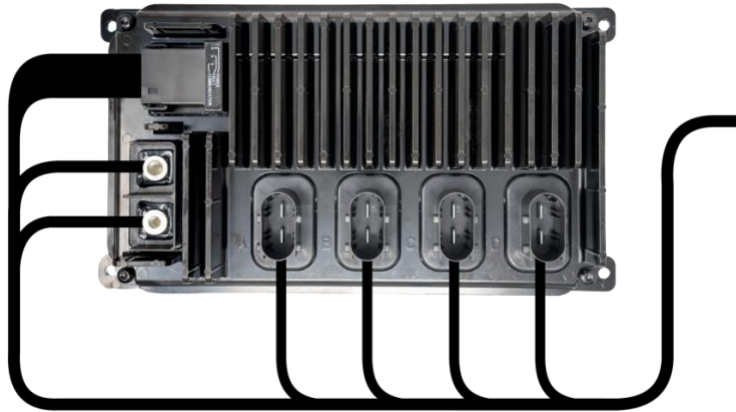

HCPDM shown in preferred mounting orientation

2.2 Dimensions

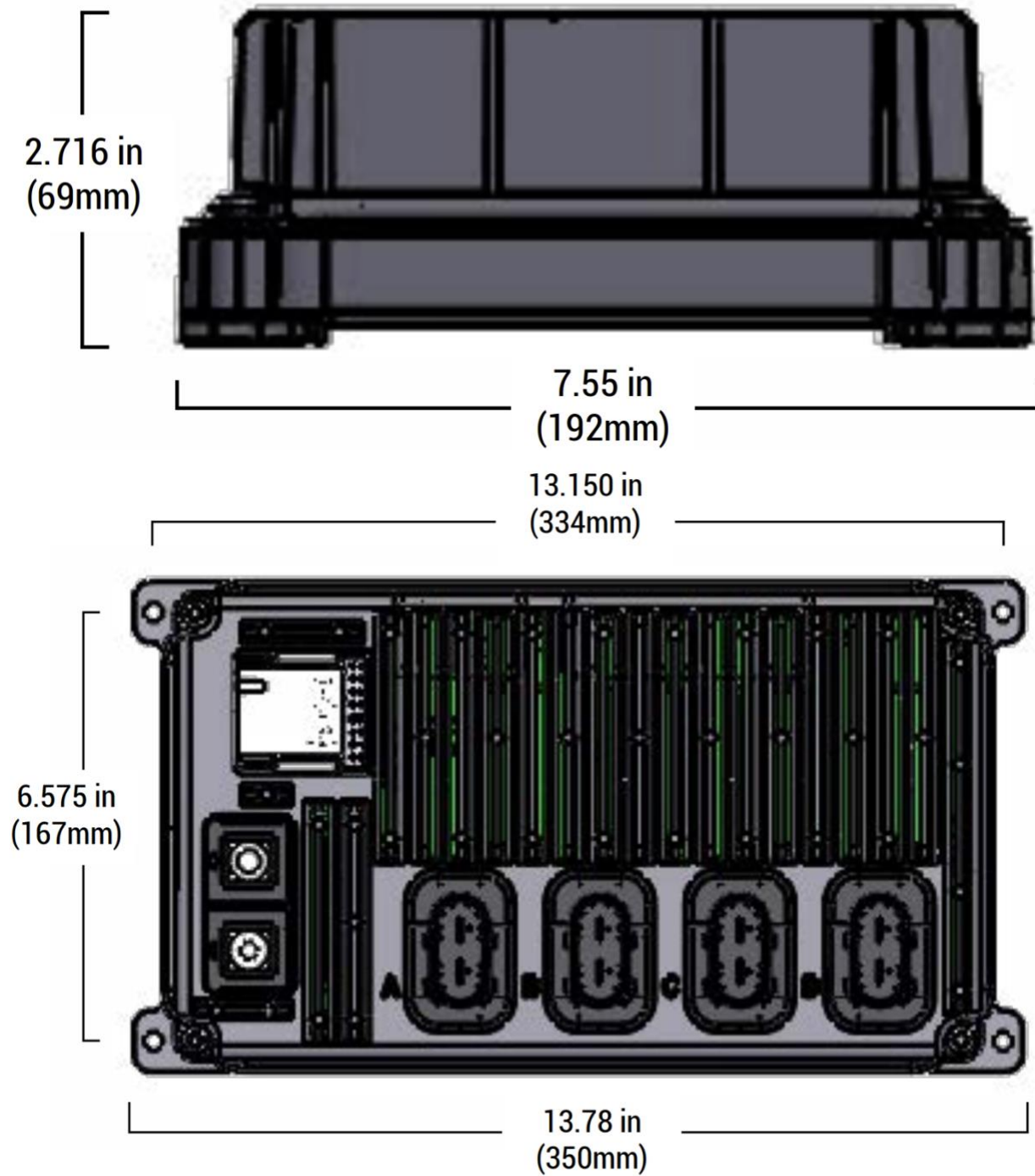

HCPDM Dimensions

2.3 Circuit Protection

A fuse or circuit breaker on the positive power input (connector J2) is required and should be located near the power source (e.g., battery).

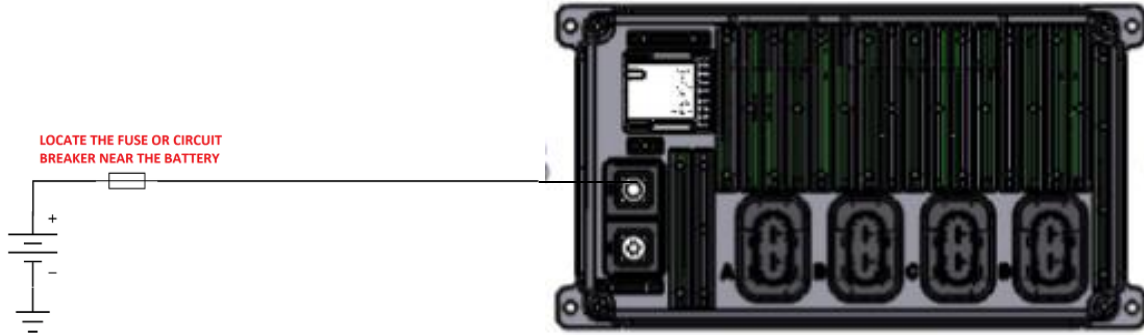

The outputs are monitored for over-current conditions and will turn off in the event of a fault. For information on how to configure the output current limit, please refer to section 4.3.2

2.4 Recommended Wiring Practices

This section contains information about the HCPDM connectors and pin outs. Please use the following recommended wiring practices when installing and using the HCPDM:

- Ensure correct and adequate single point ground to prevent ground loops.
- Use twisted or twisted shielded pair cable for the CAN bus per the applicable standard.
- Ensure the appropriate sized conductor is specified for the intended load current in the harness design for the particular application.
 - SAE J1614 specifies requirements and design guidelines for electrical wiring systems of less than 50 V and cable diameters from 0.35 mm² to 19 mm² used in off-road, self-propelled earthmoving machines as defined in SAE J1116 and agricultural tractors as defined in ASAE S390.
 - SAE J2202 recommends and describes the application of the primary wiring distribution system of less than 50 V and includes wire sizes 0.5 mm² to 19 mm² on heavy-duty on-highway trucks.
 - SAE J1128, ISO 6722 and JASO D608-92 automotive wiring standards aid in determining the recommended conductor sizing table for the respective 12V or 24V system that is powering the load. Note: The HCPDM only functions on 12V systems.
 - ABA specifies a marine wiring standard that differs from SAE J1128.
- Wire gauges should be capable of handling at least 135 percent of the circuit's current protection rating.
 - Determine the maximum load the wire is expected to carry, the location of wiring (e.g., in a cab or engine compartment) and ambient temperature.

- Determine the length of the wire needed to extend from the power source to the load. Include the ground wire length if used.
- Ensure that the voltage drop at the load is kept within the recommended 10 percent maximum level for the respective 12V power system.
- Wire gauge reductions are permissible after the point at which circuit protection is added or enabled.
- Wires should be specified with suitable insulation type for the environment. For instance, GXL (general purpose, cross-linked polyethylene insulated) wire with a medium insulation thickness has a rating of +135°C (+275°F) where the compartment temperatures can exceed +80°C (+176°F) such as the engine compartment.

NOTE: Review the individual over-current shutdown values in the configuration and use the correct wire gauge conductor to accommodate maximum load current configured.

- Use a protective fuse or circuit breaker on the positive input power lead (J2) that is sized appropriately for the HCPDM supply steady-state load current. Typical maximum load current is 60 percent - 80 percent of the fuse rating not to exceed 200 A.
- Verify that the harness is constructed to meet the needs of the application environment (e.g., shock, vibration, moisture, temperature, chemicals and impact).
- Make certain that the harness is designed and constructed to minimize induced interference resulting from EMI coupling between signal wires.
- Separate power circuits from low-level signals.
- Make provisions for drip loops to attach devices in exposed locations and prevent moisture entry and formation within the connectors.
- Provide sufficient clearance from moving parts.
- Wires routed through holes in the vehicle body/chassis should use grommets.
- Avoid sharp metal edges, fasteners and other abrasive surfaces or use protective shielding when routing harness assembly.
- Ensure exposed connectors are adequately covered with a protective style boot which is available for purchase online.
- Route wires to avoid exhaust system components or other high temperature areas. Use appropriate heat shielding or other insulation where routing is a problem.
- Avoid routing near wheel wells or provide adequate mechanical protection (e.g., convoluted conduit) to the wire assembly.

Reference AWG to mm² conductor cross sectional area

CABLE CONVERSION CHART – METRIC vs. ENGLISH				
LOW-TENSION PRIMARY CABLE – SAE J1128				
Metric	English		Metric	English
0.5 mm ²	20 Ga		8.0 mm ²	8 Ga
0.8 mm ²	18 Ga		13.0 mm ²	6 Ga
1.0 mm ²	16 Ga		19.0 mm ²	4 Ga
2.0 mm ²	14 Ga		33.6 mm ²	2 Ga
3.0 mm ²	12 Ga		42.4 mm ²	1 Ga
5.0 mm ²	10 Ga		53.5 mm ²	1/0 Ga

3 Electrical Connections

3.1 Connectors - and +

The connector pinout is as viewed looking into the PDM receptacles or from the wire side of the mating plugs. Hardware is included to secure power cables to the unit. We recommend hand torquing these to a maximum of 180 IN-LBS (Dry).

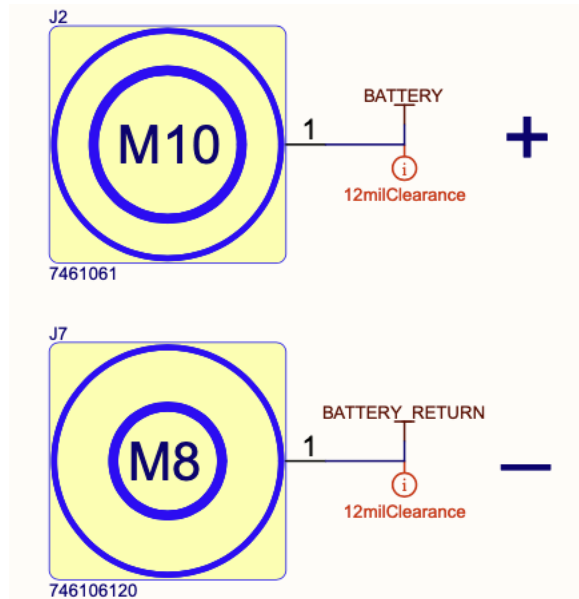

PIN	FUNCTION	LIMIT	Mating Connector
-	Ground	200 A continuous (return)	M8 bolt provided
+	V_{BATT}	200 A continuous (source)	M10 bolt provided

IMPORTANT: A circuit breaker or fuse is required on the connection leading to + and should be located near the battery or power source. Please ensure that the appropriately sized conductor is selected for the total simultaneous current that is switched.

3.2 Connector E

The connector pinout is as viewed looking into the HCPDM receptacles or from the wire side of the mating plugs.

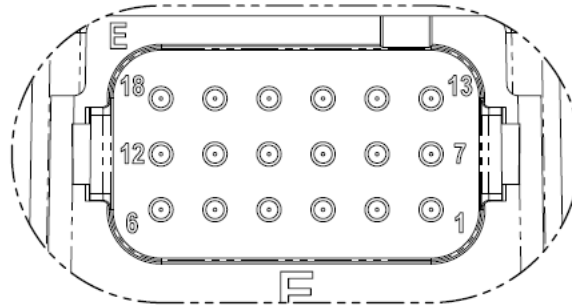

E

Pin	Function	Signal Limit	Mating Connector
E-1	Input 1	Configuration dependent	TE 934457151
E-2	Input 4	Configuration dependent	
E-3	Unused		
E-4	Unused		
E-5	High side driver 1	Vbatt @ 100 mA	
E-6	High side driver 2	Vbatt @ 100 mA	
E-7	Input 2	Configuration dependent	
E-8	Input 5	Configuration dependent	
E-9	Ignition wake	12V nominal	
E-10	Address bit 2	Gnd or Vbat/floating	
E-11	Sensor V out	5 V @ 400 mA	
E-12	Sensor return	GND	
E-13	Input 3	Configuration dependent	
E-14	Input 6	Configuration dependent	
E-15	Address bit 1	Gnd or Vbat/floating	
E-16	Address bit 0	Gnd or Vbat/floating	
E-17	CAN high		
E-18	CAN low		

3.3 Connector A

The connector pinout is as viewed looking into the HCPDM receptacles or from the wire side of the mating plugs.

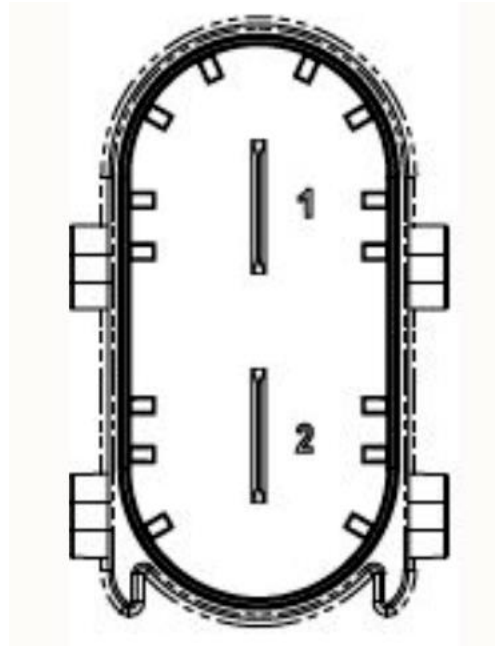

A

Pin	Function	Limit	Mating Connector
A 1	Digital Output 1	40 A (PWM @ 500 Hz)	DTE 1355328-1
A 2	Digital Output 2	40 A (PWM @ 500 Hz)	

3.4 Connector B

The connector pinout is as viewed looking into the HCPDM receptacles or from the wire side of the mating plugs.

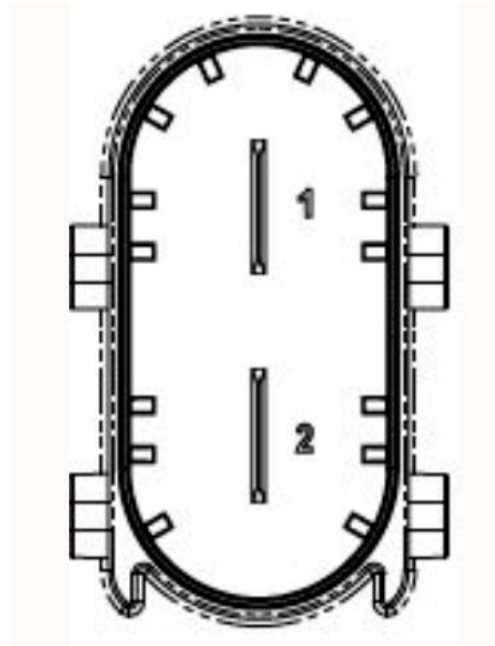

B

Pin	Function	Limit	Mating Connector
B 1	Digital Output 3	40 A (PWM @ 500 Hz)	DTE 1355328-1
B 2	Digital Output 4	40 A (PWM @ 500 Hz)	

3.5 Connector C

The connector pinout is as viewed looking into the HCPDM receptacles or from the wire side of the mating plugs.

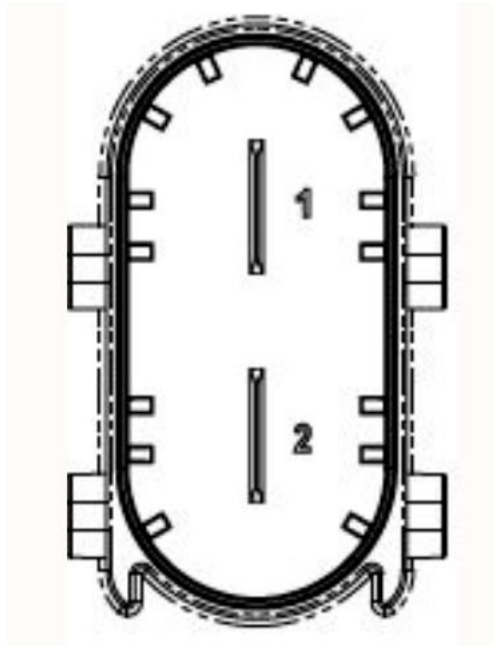

C

Pin	Function	Limit	Mating Connector
C 1	Digital Output 5	40 A (PWM @ 500 Hz)	DTE 1355328-1
C 2	Digital Output 6	40 A (PWM @ 500 Hz)	

3.6 Connector D

The connector pinout is as viewed looking into the HCPDM receptacles or from the wire side of the mating plugs.

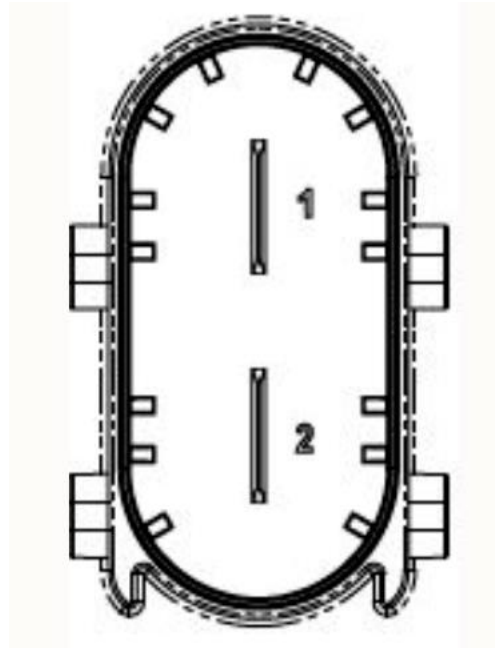

D

Pin	Function	Limit	Mating Connector
D 1	Digital Output 7	40 A (PWM @ 500 Hz)	DTE 1355328-1
D 2	Digital Output 8	40 A (PWM @ 500 Hz)	

4 Communication

4.1 Overview

The HCPDM uses proprietary SAE J1939 CAN messages to configure, control, and communicate the I/O status. PowerView displays on a compatible CAN 2.0B CAN bus device can be used to send CAN messages.

Each CAN message has an identifier in the first byte that determines the message context. There are nine unique identifiers associated with command and configuration and nine unique identifiers associated with input status, feedback, diagnostics and data reported by the PDM.

4.1.1 Source Address

The Source Address (SA) is set using three dedicated SA select inputs. A 1 indicates the input is at high potential (i.e., connected to battery positive DC). A 0 indicates the input is connected to a low potential (i.e., ground). Table 1 lists the available source addresses and allows for up to eight PDM modules on a single CAN bus. The PDM defaults to SA 40 (28h) if the inputs are not connected. The PDM does not support SA arbitration according to J1939.

Address Bit 0	Address Bit 1	Address Bit 2	SA
0	0	0	40 (28h) default
1	0	0	41 (29h)
0	1	0	42 (2Ah)
1	1	0	43 (2Bh)
0	0	1	44 (2Ch)
1	0	1	45 (2Dh)
0	1	1	46 (2Eh)
1	1	1	47 (2Fh)

Table 1 – Source Address Selection

IMPORTANT: When multiple PDMs are connected to the same CAN bus, each PDM must have a unique SA.

The PDM sends messages to and expects to receive messages from SA 17 (11h) regardless of the actual SA claimed by the configuring and controlling device(s). If a system has a cruise control or steer axle controller, the SA may conflict with the PDM.

4.1.2 Loss of Communication

The PDM expects to receive commands from a controlling device every second. If a CAN command message is not received, the PDM assumes that the CAN bus is faulted and goes into a Loss of Communication mode. Each output can be individually configured to respond in prescribed way and is further defined in the section on [Loss of Communication](#)

4.1.3 Output Modes

Two output modes of operation are possible on each channel where the PDM is configured and controlled by a PowerView display or some other CAN bus controller.

1. **High-Side Switch (HSS):** This mode of operation is the typical standard output to turn a load on or off. The individual outputs can switch up to 40 A loads. This mode also supports PWM to drive a load proportionally (open-loop).
2. **H-Bridge (HB):** This mode allows two adjacent outputs to switch polarity of the voltage applied to the load. This is often used to change direction of a DC motor and run it in reverse. This mode supports PWM to drive a load proportionally.

4.1.4 Special Methods of Operation

The PDM is a flexible power I/O module and offers the following configurable features:

4.1.4.1 Power on Reset (POR)

This mechanism enables the PDM to retain an output state through power cycles of the unit. The PDM can power up with individual outputs at predefined PWM levels.

4.1.4.2 Local Source Control

Local Source (switch) Control (LSC) is a mode that enables any digital input to trigger the respective output. The effect of this mode is to allow any number of outputs to be autonomously commanded by the specified input.

It is possible to use the PDM in stand-alone operation using LSC. Once the PDM has been configured on the production line, the unit can operate autonomously.

An example use of this function is connecting a switch to a digital input on the PDM to power an output, which in turn energizes the remainder of the electronic modules that are driven by the switch.

Using this feature inhibits the other output modes of operation such as the PWM values on the specific outputs configured for LSC mode.

IMPORTANT: Configuring LSC mode on an output disables the Loss of Communication function for the respective output since there is no way of knowing if CAN communication is expected or not.

4.2 Naming and Numbering Conventions

The byte/bit order is represented in the following figure. Bit 1 is the least significant bit (LSB) and Bit 8 is the most significant bit (MSB). Byte 1 is the transmitted first and Byte 8 is last (i.e., sequential).

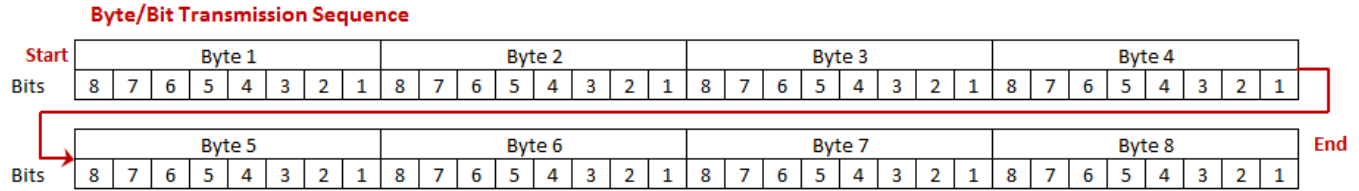

The structures are defined for each type of configuration, control, feedback and diagnostic message.

The following example message structure closely follows the SAE J1939 PGN convention. The message must contain 8 bytes.

Example Message

Data Length 8 bytes

Start Position	Length	Parameter Name	Reference
1	1 byte	Feedback and Diagnostics Identifier	4.5.1.1
2	1 byte	Analog CH 1 or 4 LSB	4.5.1.2
3	1 byte	Analog CH 1 or 4 MSB	4.5.1.2
4	1 byte	Analog CH 2 or 5 LSB	4.5.1.2
5	1 byte	Analog CH 2 or 5 MSB	4.5.1.2
6	1 byte	Analog CH 3 or 6 LSB	4.5.1.2
7	1 byte	Analog CH 3 or 6 MSB	4.5.1.2
8	1 byte	Not used FF	

Bit placement is sequential from the starting byte/bit position. For example, an analog input on channel 1 is expressed as a 16 bit value in 2 bytes of data. The start position is given as 2 meaning byte 2. The 16 bits are ordered starting in byte 2 and continue throughout byte 3. The illustration below shows the numeric value to represent 4000 mV: 4000 (FA0h) or 0000 1111 1010 0000 in binary format in the dark gray portion. The light gray bits are not used.

Example Start Position

	Byte 1								Byte 2								Byte 3								Byte 4							
Bits	8	7	6	5	4	3	2	1	8	7	6	5	4	3	2	1	8	7	6	5	4	3	2	1	8	7	6	5	4	3	2	1
Data	1	0	0	0	0	0	0	0	1	0	1	0	0	0	0	0	0	0	0	0	1	1	1	1								

NOTE: As specified by J1939, unused data bits are filled with 1 and report back as 0.

4.3 Configuring

The HCPDM is configured via the CAN bus messages for either slave or LSC (autonomous) operation. In the slave configuration, where a PowerView display or a CAN bus controller is controlling the PDM, it is recommended that the configuration messages be sent on every power-up. It is also possible to re-configure the PDM on the fly.

The following 5 message types define how to configure the PDM:

- [Configure Motor Model & Output](#)
- [Configure Output Channels](#)

The following CAN message also configures the outputs in two groups.

Configure Output Channels is a message sent to the HCPDM to set up the high-current output channels as a single high-side output or as an H-bridge pair. It also sets the current limit and reset behavior. Depending on the output configuration identifier, the message applies to either output channels 1-4 or 5-8 respectively.

Note: When channels are set to H-bridge pair, they are paired consecutively (i.e. 1 and 2, 3 and 4, etc.).

Transmission Repetition	On change of state (at least one time, < 1 sec)		
Data Length	8 bytes		
Data Page	0		
PDU Format (PF)	239	Proprietary A, PDU1 format	
PDU Specific (PS)	40 (28h) or as set	DA (Source Address of the PDM)	
Priority	5		
Parameter Group Number	61184 (EF00h)		

Start Position	Length	Parameter Name	Reference
1	1 byte	Output Channel Group Identifier	4.3.2.1
2.5	4 bits	Current Limit (Output Channel 1 or 5)	4.3.2.2

2.3	2 bits	Feedback Type (Output Channel 1 or 5)	4.3.2.3
2.2	1 bit	Automatic Reset (Output Channel 1 or 5)	4.3.2.3
2.1	1 bit	High-Side or H-Bridge (Output Channel 1 or 5)	4.3.2.5
3.5	4 bits	Current Limit (Output Channel 2 or 6)	4.3.2.2
3.3	2 bits	Feedback Type (Output Channel 2 or 6)	4.3.2.3
3.2	1 bit	Automatic Reset (Output Channel 2 or 6)	4.3.2.3
3.1	1 bit	High-Side or H-Bridge (Output Channel 2 or 6)	4.3.2.5
4.5	4 bits	Current Limit (Output Channel 3 or 7)	4.3.2.2
4.3	2 bits	Feedback Type (Output Channel 3 or 7)	4.3.2.3
4.2	1 bit	Automatic Reset (Output Channel 3 or 7)	4.3.2.3
4.1	1 bit	High-Side or H-Bridge (Output Channel 3 or 7)	4.3.2.5
5.5	4 bits	Current Limit (Output Channel 4 or 8)	4.3.2.2
5.3	2 bits	Feedback Type (Output Channel 4 or 8)	4.3.2.3
5.2	1 bit	Automatic Reset (Output Channel 4 or 8)	4.3.2.3
5.1	1 bit	High-Side or H-Bridge (Output Channel 4 or 8)	4.3.2.5
6.5	4 bits	Current Limit (Output Channel 5 or 11)	4.3.2.2
6	1 byte	Not used	
7	1 byte	Not used	
8	1 byte	Reserved (FFh)	

4.3.2.1. Output Channel Group Identifier

This identifier is a secondary address that determines which set of outputs will be configured.

Identifier:	6 Output Channels 1-4 7 Output Channels 5-8		
Data Length:	1 byte		
Resolution:	2 states / 1 byte	0 offset	
Data Range:	0	Operational Range:	same as data range
Type:	Status (command)		
PGN:	PGN 61184 – Configure Output Channels		

4.3.1.1 Current Limit

Current Limit sets the steady-state, over-current shutdown level starting at 5.0A in 2.5A increments.

- 0 – 0 A
- 1 – 5.0 A

- 2 – 7.5 A
- 3 – 10.0 A
- 4 – 12.5 A
- 5 – 15.0 A
- 6 – 17.5 A
- 7 – 20.0 A
- 8 – 22.5 A
- 9 – 25.0 A
- 10 – 27.5 A
- 11 – 30.0 A
- 12 – 32.5 A
- 13 – 35.0 A
- 14 – 37.5 A
- 15 – 40.0 A

Data Length: 4 bits
Resolution: 16 states / 4 bits 0 offset
Data Range: 0 A – 40 A Operational Range: same as data range
Type: Status (command)
PGN: PGN 61184 – Configure Output Channels

4.3.1.3 Feedback Type

Feedback type is usually set to Current. Position feedback is a special application use case in the marine market. The other modes are not supported on the HCPDM.

- 00 Position feedback (special use case for marine)
- 01 Rate feedback (not supported on the HCPDM)
- 10 Power feedback (not supported on the HCPDM)
- 11 Current feedback (always)

Data Length: 2 bits
Resolution: 4 states / 2 bits 0 offset
Data Range: 3 Operational Range: same as data range
Type: Status (measured)
PGN: PGN 61184 Configure Output Channels or [Output Configuration Handshake](#)

4.3.1.4 Automatic Reset

Automatic Reset specifies if the PDM shall autonomously reset the output or remain in the OFF state during an over-current event. Once an output is turned OFF by the PDM, the output needs to be commanded OFF prior to commanding the output.

- 0 Automatic reset (5 attempts to reset before remaining OFF) Is this the correct number of retries?
- 1 No automatic reset (remain in OFF state)

Data Length: 1 bit

Resolution: 2 states / 1 bit 0 offset
Data Range: 0 Operational Range: same as data range
Type: Status (command)
PGN: PGN 61184 – Configure Output Channels or [Output Configuration Handshake](#)

4.3.1.5 High-Side or H-Bridge

High-side or H-Bridge configures either a single output for driving discrete loads or assigns a pair of outputs for directional motor control. H-Bridge pairs are grouped as follows: 1 and 2, 3 and 4, 5 and 6, etc.

Note: When configuring the output for H-bridge operation, the second channel in the pair (even number) must have the configuration byte set to 255 in the Configuration message.

0 High-Side (single)
1 H-Bridge (dual)

Data Length: 1 bit

Resolution: 2 states / 1 bit 0 offset

Data Range: 0 Operational Range: same as data range

Type: Status (command)

PGN: PGN 61184 – Configure Output Channels

-
- [Configure Analog Inputs](#)
- [Configure Miscellaneous](#)
- [Configure Position](#)

PowerVision Configuration Studio® 8.9.0 and later versions have a development application which makes it easy to configure and control the Output Functions and Channels using PowerView displays.

See the PowerVision Applications Reference Manual for further details on the use of the application.

4.3.2 Configure Motor Model & Output Function

The Configure Motor Model & Output Function message sets the mode, power-on characteristics and general behavior for each output. The message must be sent at least one time for LSC and as often as required if the output configuration needs to change. A handshake message is returned by the HCPDM to confirm the setup.

CAN message sent to the HCPDM to set up the configuration or command the outputs.

Transmission Repetition	On change of state	
Data Length	8 bytes	
Data Page	0	
PDU Format (PF)	239	Proprietary A, PDU1 format
PDU Specific (PS)	40 (28h) or as set	DA (Source Address of the PDM)
Priority	5	
Parameter Group Number	61184 (EF00h)	

Start Position	Length	Parameter Name	Reference
1	1 byte	Configuration or Command Identifier	4.3.1.1
2	1 byte	Output Channel Number	4.3.1.2
3	1 byte	Soft-Start Step Size	4.3.1.3
4	1 byte	Motor/Lamp Mode	4.3.1.4
5.3	6 bits	Reserved (Always high, binary 111111)	
5.1	2 bits	Loss of Communication	4.3.1.5
6.1	1 bit	Command Mode	4.3.1.6
7.4	5 bits	POR Command	4.3.1.7
7.3	1 bit	POR Enable	4.1.3.8
7.2	1 bit	Command Type Bit (Loss of CAN enable/disable)	4.3.1.9
7.1	1 bit	Motor Braking	4.3.1.10
8.5	4 bits	LSC Digital Input	4.3.1.11
8.3	2 bits	Calibration Time	4.3.1.12
8.1	2 bits	Response	4.3.1.13

4.3.2.1 Configuration Identifier

This identifier is a secondary address that indicates the type of message, in this case output functionality.

Identifier: 0 Configuration Motor Model
Data Length: 1 byte
Resolution: NA 0 offset
Data Range: NA Operational Range: same as data range
Type: Identifier
PGN: PGN 61184 – [Configure Output Channels](#)

4.3.2.2 Output Channel

This specifies which output channel, 1 - 8, is configured by the message.

1 = Channel 1, 2 = Channel 2, 3 = Channel 3, etc.

Data Length: 1 byte
Resolution: NA 0 offset
Data Range: 1 to 8 Operational Range: same as data range
Type: Status (command)
PGN: PGN 61184 – [Configure Output Channels](#)

4.3.2.3 Soft-Start Step Size

Motors and lamps often require soft-starting to reduce the in-rush current and prevent the PDM from producing over-current errors. Also lights can be soft-started to reduce the in-rush current and potentially extend the filament life.

1 = 0.78125%, 2 = 1.5625%, 3 = 2.34375%, etc.

255 (FFh) = 100% (Soft-Start disabled)

Data Length: 1 byte
Resolution: 0.78125% / 1 bit 0 offset
Data Range: 1 to 100 Operational Range: same as data range
Type: Status (command)
PGN: PGN 61184 – [Configure Output Channels](#)

Soft-start step size is a PWM value representing a percentage in which the output is increased in steps. Depending on the mode (i.e., lamp or motor) selected, the time between each step varies. The first step lasts 500 ms in either mode. The subsequent steps are only 20 ms in lamp mode. Alternately, the motor mode remains at 500 ms step intervals. Lower percentage soft-start values therefore equate to longer soft-start times.

For example, a soft-start value of 10% using lamp mode means that the PDM reaches 100% after 680 ms. Whereas the same 10% value using motor mode takes 5,000 ms to reach 100%. The illustrations below show the time base of an example 10% PWM value.

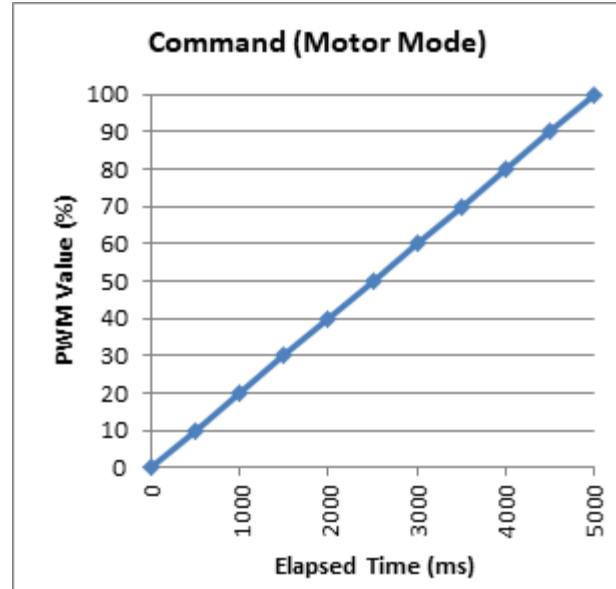
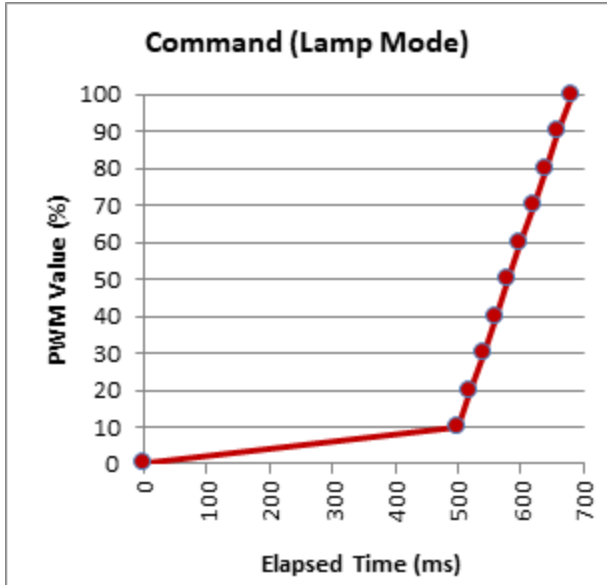

Depending on the Command (final) value and the soft-start step size, the elapsed time to reach the final PWM value may vary by one or two steps.

4.3.2.4 Motor/Lamp Mode

The soft start time between steps highlighted above is selected depending on the type of load (motor or lamp).

0 Lamp
1 Motor

Data Length: 1 byte
Resolution: 2 states / 1 byte 0 offset
Data Range: 0 to 1 Operational Range: same as data range
Type: Status (command)
PGN: PGN 61184 – [Configure Output Channels](#)

The Soft-Start function can be used in combination with the motor/lamp mode to affect the inrush current and prevent an over-current condition.

NOTE: The inductance of the motor, inertia of the rotor and load, including a stalled rotor condition factor into whether the HCPDM is capable of driving a DC motor. Experimentation is often necessary to determine if a DC motor is compatible with the HCPDM.

4.3.2.5 Loss of Communication

Defines how the outputs behave when CAN communication is lost. This can be useful in many applications, but because the HCPDM is no longer under supervisory control, appropriate testing should be conducted to ensure safe operation.

00 = CH Unchanged (Last Commanded)

01 = CH -100% (H-Bridge Only)

10 = CH +100%

11 = CH 0% (off)

Data Length: 2 bits

Resolution: 4 states / 2 bits 0 offset

Data Range: 0 to 3 Operational Range: same as data range

Type: Status (command)

PGN: PGN 61184 – [Configure Output Channels](#)

4.3.1.6 Command Mode

The Command Mode sets the output for PWM or Position.

0 PWM

1 Position

Data Length: 1 byte

Resolution: 2 states / 1 byte 0 offset

Data Range: 0 to 1 Operational Range: same as data range

Type: Status (command)

PGN: PGN 61184 [Configure Output Channels](#)

4.3.2.7 POR Command

The POR Command sets the percentage PWM level for each output at module power on/reset. This establishes the output PWM level an individual output will be commanded to at start up. This can be useful in many applications, but because the HCPDM is no longer under supervisory control, appropriate testing should be conducted to ensure safe operation.

Data Length: 5 bits, signed

Resolution: 6.25 % / LSB -100 % offset

Data Range: -100 % to 100 % Operational Range: same as data range

Type: Status (command)

PGN: PGN 61184 – [Configure Output Channels](#)

POR Command Value	Commanded PWM %	Actual PWM %
01111	93.75	100
01110	87.5	87.5
01101	81.25	81.25
01100	75	75
01011	68.75	68.75
01010	62.5	62.5
01001	56.25	56.25
01000	50	50
00111	43.75	43.75
00110	37.5	37.5
00101	31.25	31.25
00100	25	25
00011	18.75	18.75
00010	12.5	12.5
00001	6.25	6.25
00000	0	0
11111	-6.25	-6.25
11110	-12.5	-12.5
11101	-18.75	-18.75
11100	-25	-25
11011	-31.25	-31.25
11010	-37.5	-37.5
11001	-43.75	-43.75
11000	-50	-50
10111	-56.25	-56.25
10110	-62.5	-62.5
10101	-68.75	-68.75
10100	-75	-75
10011	-81.25	-81.25
10010	-87.5	-87.5
10001	-93.75	-93.75
10000	-100	-100

4.3.2.8 POR Enable

POR enables the above power on reset functionality for the individual output.

1 Disabled

0 Enabled

Data Length: 1 bit

Resolution: 2 states / 1 bit 0 offset

Data Range: 0 to 1 Operational Range: same as data range

Type: Status (command)

PGN: PGN 61184 – [Configure Output Channels](#)

4.3.2.9 Command Type

Command type determines if the loss of CAN feature is enabled or disabled.

0 Enabled

1 Disabled

Data Length: 1 bit

Resolution: 2 states / 1 bit 0 offset

Data Range: 0 to 1 Operational Range: same as data range

Type: Status (command)

PGN: PGN 61184 - [Configure Output Channels](#)

4.3.2.10 Motor Braking

Motor braking for H-bridge controlled outputs. This enables motor braking for the specific H-Bridge pair.

0 Disabled

1 Enabled

Data Length: 1 bit

Resolution: 2 states / 1 bit 0 offset

Data Range: 0 to 1 Operational Range: same as data range

Type: Status (command)

PGN: PGN 61184 – [Configure Output Channels](#)

4.3.2.11 LSC Digital Input

Specifies the Digital Input number that is associated with the output channel for the LSC mode.

- 0 Channel 1
- 1 Channel 2
- 2 Channel 3
- 3 Channel 4
- 4 Channel 5
- 5 Channel 6
- 15 (0xF) LSC disabled (default)

NOTE: When not using LSC, all 4 bits must be 1111 (0x15). The two bits associated with calibration time below, since it is unsupported, must be 11. The two bits associated with Response below must also be 11. Therefore, when not using LSC, Byte 8 must be 0xFF.

Data Length: 4 bits
Resolution: NA 0 offset
Data Range: 0-5, 15 Operational Range: same as data range
Type: Status (command)
PGN: PGN 61184 – [Configure Output Channels](#)

4.3.2.12 Calibration Time

Calibration time. This feature is not currently supported.

- 0 Override Fixed (always 0 for H-bridge)
- 1 Override Calibration Time

NOTE: Since this feature is unsupported, these two bits must always be 11.

Data Length: 2 bits
Resolution: 2 states / 2 bits 0 offset
Data Range: 0 to 1 Operational Range: same as data range
Type: Status (command)
PGN: PGN 61184 – [Configure Output Channels](#)

4.3.2.13 Response

Response indicates how the output channel turns-on depending on the input is active low, high or both (either low or high).

- 00 Reserved
- 01 Active Low
- 10 Active High
- 11 Active Low or High

Data Length: 2 bits
Resolution: 2 states / 2 bits 0 offset
Data Range: 0 to 1 Operational Range: same as data range
Type: Status (command)
PGN: PGN 61184 – [Configure Output Channels](#)

4.3.3 Configure Output Channels

The following CAN message also configures the outputs in two groups.

Configure Output Channels is a message sent to the HCPDM to set up the high-current output channels as a single high-side output or as an H-bridge pair. It also sets the current limit and reset behavior. Depending on the output configuration identifier, the message applies to either output channels 1-4 or 5-8 respectively.

Note: When channels are set to H-bridge pair, they are paired consecutively (i.e. 1 and 2, 3 and 4, etc.).

Transmission Repetition	On change of state (at least one time, < 1 sec)	
Data Length	8 bytes	
Data Page	0	
PDU Format (PF)	239	Proprietary A, PDU1 format
PDU Specific (PS)	40 (28h) or as set	DA (Source Address of the PDM)
Priority	5	
Parameter Group Number	61184 (EF00h)	

Start Position	Length	Parameter Name	Reference
1	1 byte	Output Channel Group Identifier	4.3.2.1
2.5	4 bits	Current Limit (Output Channel 1 or 5)	4.3.2.2
2.3	2 bits	Feedback Type (Output Channel 1 or 5)	4.3.2.3
2.2	1 bit	Automatic Reset (Output Channel 1 or 5)	4.3.2.3
2.1	1 bit	High-Side or H-Bridge (Output Channel 1 or 5)	4.3.2.5
3.5	4 bits	Current Limit (Output Channel 2 or 6)	4.3.2.2
3.3	2 bits	Feedback Type (Output Channel 2 or 6)	4.3.2.3
3.2	1 bit	Automatic Reset (Output Channel 2 or 6)	4.3.2.3
3.1	1 bit	High-Side or H-Bridge (Output Channel 2 or 6)	4.3.2.5
4.5	4 bits	Current Limit (Output Channel 3 or 7)	4.3.2.2
4.3	2 bits	Feedback Type (Output Channel 3 or 7)	4.3.2.3
4.2	1 bit	Automatic Reset (Output Channel 3 or 7)	4.3.2.3
4.1	1 bit	High-Side or H-Bridge (Output Channel 3 or 7)	4.3.2.5
5.5	4 bits	Current Limit (Output Channel 4 or 8)	4.3.2.2
5.3	2 bits	Feedback Type (Output Channel 4 or 8)	4.3.2.3
5.2	1 bit	Automatic Reset (Output Channel 4 or 8)	4.3.2.3
5.1	1 bit	High-Side or H-Bridge (Output Channel 4 or 8)	4.3.2.5

6.5	4 bits	Current Limit (Output Channel 5 or 11)	4.3.2.2
6	1 byte	Not used	
7	1 byte	Not used	
8	1 byte	Reserved (FFh)	

4.3.2.2. Output Channel Group Identifier

This identifier is a secondary address that determines which set of outputs will be configured.

Identifier:	6 Output Channels 1-4 7 Output Channels 5-8		
Data Length:	1 byte		
Resolution:	2 states / 1 byte	0 offset	
Data Range:	0	Operational Range:	same as data range
Type:	Status (command)		
PGN:	PGN 61184 – Configure Output Channels		

4.3.3.2 Current Limit

Current Limit sets the steady-state, over-current shutdown level starting at 5.0A in 2.5A increments.

- 0 – 0 A
- 1 – 5.0 A
- 2 – 7.5 A
- 3 – 10.0 A
- 4 – 12.5 A
- 5 – 15.0 A
- 6 – 17.5 A
- 7 – 20.0 A
- 8 – 22.5 A
- 9 – 25.0 A
- 10 – 27.5 A
- 11 – 30.0 A
- 12 – 32.5 A
- 13 – 35.0 A
- 14 – 37.5 A
- 15 – 40.0 A

Data Length:	4 bits		
Resolution:	16 states / 4 bits	0 offset	
Data Range:	0 A – 40 A	Operational Range:	same as data range
Type:	Status (command)		
PGN:	PGN 61184 – Configure Output Channels		

4.3.3.3 Feedback Type

Feedback type is usually set to Current. Position feedback is a special application use case in the marine market. The other modes are not supported on the HCPDM.

- 00 Position feedback (special use case for marine)
- 01 Rate feedback (not supported on the HCPDM)
- 10 Power feedback (not supported on the HCPDM)
- 11 Current feedback (always)

Data Length: 2 bits
Resolution: 4 states / 2 bits 0 offset
Data Range: 3 Operational Range: same as data range
Type: Status (measured)
PGN: PGN 61184 [Configure Output Channels](#) or [Output Configuration Handshake](#)

4.3.3.4 Automatic Reset

Automatic Reset specifies if the PDM shall autonomously reset the output or remain in the OFF state during an over-current event. Once an output is turned OFF by the PDM, the output needs to be commanded OFF prior to commanding the output.

- 0 Automatic reset (5 attempts to reset before remaining OFF) Is this the correct number of retries?
- 1 No automatic reset (remain in OFF state)

Data Length: 1 bit
Resolution: 2 states / 1 bit 0 offset
Data Range: 0 Operational Range: same as data range
Type: Status (command)
PGN: PGN 61184 – [Configure Output Channels](#) or [Output Configuration Handshake](#)

4.3.3.5 High-Side or H-Bridge

High-side or H-Bridge configures either a single output for driving discrete loads or assigns a pair of outputs for directional motor control. H-Bridge pairs are grouped as follows: 1 and 2, 3 and 4, 5 and 6, etc.

Note: When configuring the output for H-bridge operation, the second channel in the pair (even number) must have the configuration byte set to 255 in the Configuration message.

0 High-Side (single)
1 H-Bridge (dual)

Data Length: 1 bit
Resolution: 2 states / 1 bit 0 offset
Data Range: 0 Operational Range: same as data range
Type: Status (command)
PGN: PGN 61184 – [Configure Output Channels](#)

4.3.4 Configuring Analog Input Channels

The following CAN message configures the input channels

Configure Analog CH 1-6 is a message sent to the HCPDM to set up each of the inputs. There are 5 configurable input type options available.

Transmission Repetition On change of state (at least one time, < 1 sec)
Data Length 8 bytes
Data Page 0
PDU Format (PF) 239 Proprietary A, PDU1 format
PDU Specific (PS) 40 (28h) or as set DA (Source Address of the PDM)
Priority 5
Parameter Group Number 61184 (EF00h)

Start Position	Length	Parameter Name	Reference
1	1 byte	Message Identifier	4.3.3.1
2.3	3 bits	Input Channel 1 Configuration	4.3.3.2
3.3	3 bits	Input Channel 2 Configuration	4.3.3.2
4.3	3 bits	Input Channel 3 Configuration	4.3.3.2
5.3	3 bits	Input Channel 4 Configuration	4.3.3.2

6.3	3 bits	Input Channel 5 Configuration	4.3.3.2
7.3	3 bits	Input Channel 6 Configuration	4.3.3.2
8	1 byte	Reserved (FFh)	

4.3.4.1 Message Identifier

This identifier is a secondary address that indicates the type of message, in this case analog input configuration.

Identifier:	8 Configuration Analog 1 - 6		
Data Length:	1 byte		
Resolution:	9 states / 1 byte	0 offset	
Data Range:	0	Operational Range:	same as data range
Type:	Status (command)		
PGN:	PGN 61184 – Configure Motor Model & Output		

4.3.4.2 Analog Input Channel Configuration

The 6 analog inputs are configured using the first 3 bits of the associated byte. The configuration options are as follows on a per channel basis: 0 – Voltage, 1 – Current, 2 – Resistance, 3 – Digital High, 4 – Digital Low.

4.3.5 Configuring MISC

The following CAN message configures sensor supply and ignition input

Configure MISC is a message sent to the HCPDM to set up the sensor supply and the ignition input.

Transmission Repetition	On change of state (at least one time, < 1 sec)		
Data Length	8 bytes		
Data Page	0		
PDU Format (PF)	239	Proprietary A, PDU1 format	
PDU Specific (PS)	40 (28h) or as set	DA (Source Address of the PDM)	
Priority	5		
Parameter Group Number	61184 (EF00h)		

Start Position	Length	Parameter Name	Reference
1	1 byte	Message Identifier	4.3.4.1
2.1	1 bit	Sensor Supply (ignored – always 5V)	
3.1	1 bit	Sensor Supply Enable	4.3.4.2
4.1	1 bit	Ignition Enable	4.3.4.3
5	1 byte	Not used	

6	1 byte	Not used
7	1 byte	Not used
8	1 byte	Not used

[Error! Reference source not found.](#)

4.3.5.1 Message Identifier

This identifier is a secondary address that indicates the type of message, in this case configuring miscellaneous.

Identifier:	10 Configuring miscellaneous	
Data Length:	1 byte	
Resolution:	NA	0 offset
Data Range:	0	Operational Range: same as data range
Type:	Status (command)	
PGN:	PGN 61184 – Configure Motor Model & Output	

This message identifier is the secondary address that signifies the type of message, in this case the configuration for the sensor supply and ignition enable. Sensor Supply is enabled with 1, disabled with 0. The Ignition is enabled with 1, disabled with 0.

4.3.5.2 Sensor Supply Enable

Sensor Supply is enabled with 1, disabled with 0.

4.3.5.3 Ignition Enable

The Ignition is enabled with 1, disabled with 0. This is used to wake the HCPDM from sleep.

4.3.6 Configuring Position

The following CAN message configures the position feedback

Configure Position is a message sent to the HCPDM to set up each of the outputs using position feedback. There are 6 configurable parameter options available.

Transmission Repetition	On change of state (at least one time, < 1 sec)	
Data Length	8 bytes	
Data Page	0	
PDU Format (PF)	239	Proprietary A, PDU1 format
PDU Specific (PS)	40 (28h) or as set	DA (Source Address of the PDM)
Priority	5	
Parameter Group Number	61184 (EF00h)	

Start Position	Length	Parameter Name	Reference
1	1 byte	Message Identifier	4.3.5.1
2	1 byte	Output Channel #	4.3.5.2
3	1 byte	Position Hysteresis	4.3.5.3
4	1 byte	Stalled Resistance LSB	4.3.5.4
5	1 byte	Stalled Resistance MSB	4.3.5.4
6	1 byte	Gain LSB	4.3.5.5
7	1 byte	Gain MSB	4.3.5.5
8	1 byte	Position (0 – 100%)	4.3.5.6

4.3.6.1 Message Identifier

This identifier is a secondary address that indicates the type of message, in this case configure position.

Identifier:	11 Configuration Position
Data Length:	1 byte
Resolution:	NA 0 offset
Data Range:	0 Operational Range: same as data range
Type:	Status (command)
PGN:	PGN 61184 – Configure Motor Model & Output

This message identifier is the secondary address that signifies the type of message, in this case the configuration for the position. Sensor Supply is enabled with 1, disabled with 0. The Ignition is enabled with 1, disabled with 0.

4.3.6.2 Output Channel

This specifies which output channel, 1 - 8, is configured by the message.

1 = Channel 1, 2 = Channel 2, 3 = Channel 3, etc.

Data Length:	1 byte
Resolution:	8 states / 1 byte 0 offset
Data Range:	1 to 8 Operational Range: same as data range
Type:	Status (command)
PGN:	PGN 61184 – Configure Motor Model & Output

4.3.6.3 Position Hysteresis

This specifies the output channel position % hysteresis.

1/16% per LSB.

Data Length: 1 byte
Resolution: 255 states / 1 byte (0.0625%/bit) 0 offset
Data Range: 0 to 15.9375 Operational Range: same as data range
Type: Status (command)
PGN: PGN 61184 – [Configure Motor](#) Model & Output

4.3.6.4 Stalled resistance

This specifies the motor stalled resistance value in ohms for the load that is connected at the output.

Data Length: 2 byte
Resolution: 1/512Ω per bit 0 offset
Data Range: 0 to 128 Ω Operational Range: same as data range
Type: Status (command)
PGN: PGN 61184 – [Configure Motor](#) Model & Output

4.3.6.5 Gain

This specifies the gain value used in the position mode (this is experimentally derived).

Data Length: 2 bytes
Resolution: 16 bit 0 offset
Data Range: 1 to 65535 Operational Range: same as data range
Type: Status (command)
PGN: PGN 61184 – [Configure Motor](#) Model & Output

4.3.6.6 Position

This specifies the position value as a 0 – 100% of range used to set position. (note FF ignores this value).

Data Length: 1 byte
Resolution: 1%/bit 0 offset
Data Range: 1 to 100 Operational Range: same as data range
Type: Status (command)
PGN: PGN 61184 – [Configure Motor](#) Model & Output

4.4 Commanding

After the configuration is complete, the HCPDM outputs can be commanded. The following message type defines how to command the PDM:

- [Command Output Channels](#)

4.4.1 Command Output Channels

The command output channels message sets the PWM value of each output channel. The message bytes refer to outputs 1-4 or 5-8, depending on the value of the identifier in the first byte.

NOTE: A Command message must be broadcast to the PDM at least once every second. Otherwise the PDM enters the Loss of Communication state.

CAN message sent to the PDM to drive the outputs.

Transmission Repetition	20 – 500 ms	
Data Length	6 bytes	
Data Page	0	
PDU Format (PF)	239	Proprietary A, PDU1 format
PDU Specific (PS)	40 (28h) or as set	DA (Source Address of the PDM)
Priority	5	
Parameter Group Number	61184 (EF00h)	

Start Position	Length	Parameter Name	Reference
1	1 byte	Output Command Identifier	4.4.1.1
2	1 byte	Command (Output Channel 1 or 5)	4.4.1.2
3	1 byte	Command (Output Channel 2 or 6)	4.4.1.2
4	1 byte	Command (Output Channel 3 or 7)	4.4.1.2
5	1 byte	Command (Output Channel 4 or 18)	4.4.1.2
6	1 byte	Not used (FF)	4.4.1.2
7	1 byte	Not used (FF)	4.4.1.2
8.1	1 bit	Enable (Output Channel 1 or 5)	4.4.1.3
8.2	1 bit	Enable (Output Channel 2 or 6)	4.4.1.3
8.3	1 bit	Enable (Output Channel 3 or 7)	4.4.1.3

8.4	1 bit	Enable (Output Channel 4 or 8)	4.4.1.3
8.5	1 bit	Not used always 1	4.4.1.3
8.6	1 bit	Not used always 1	4.4.1.3
8.7	2 bits	HCPDM Transmit Rate Command ID4/ Unused Command ID5	4.4.1.4

4.4.1.1 Output Command Identifier

This value defines which output channels the Command Output Channels message is referencing.

Identifier:	4 Output Channels 1-4 5 Output Channels 5-8		
Data Length:	1 byte		
Resolution:	2 states / 1 byte	0 offset	
Data Range:	4 or 5	Operational Range:	same as data range
Type:	Status (command)		
PGN:	PGN 61184 – Command Output Channels		

4.4.1.2 Command

This value defines the output channel's PWM value as a percentage. This is a signed 8 bit value (MSB is the sign bit). Note: special case when set for position, the resolution is 1%/LSB and the range is 0 -100%.

Note: When an output is either disabled or the second channel in an H-bridge pair, the command should be set to 0 for that channel.

0	0%
1	+0.78125%
...	
127	+100%
128	-100%
...	
255	-0.78125%

Data Length:	1 byte		
Resolution:	0.78125 % / LSB	0 offset	
Data Range:	-100% to +100%	Operational Range:	same as data range
Type:	Status (command)		
PGN:	PGN 61184 – Command Output Channels		

IMPORTANT: It may be necessary to turn on the outputs in a staggered manner when multiple high-current loads need to be energized due to the high inrush current.

4.4.1.3 Enable

This value defines whether the specified channel is enabled or disabled.

NOTE: When a channel is disabled, it must have configuration byte set to 255 (FFh).

0 Disabled
1 Enabled

Data Length: 1 bit
Resolution: 2 states / 1 bit 0 offset
Data Range: 0 or 1 **Operational Range:** same as data range
Type: Status (command)
PGN: PGN 61184 – [Command Output Channels](#)

4.4.1.4 Module Transmit Rate

This value defines the repetition rate that the PDM will transmit the feedback and diagnostics.

00 500ms
01 250ms
02 50ms
03 10ms

Data Length: 2 bits
Resolution: 4 states / 2 bits 0 offset
Data Range: 0 to 3 **Operational Range:** same as data range
Type: Status (command)
PGN: PGN 61184 – [Command Output Channels](#)

4.4.2 Command High Side Output

The Command High Side Output message is used to energize/de-energize either of the 2 low current digital outputs.

NOTE: A Command message must be broadcast to the PDM at least once every second. Otherwise the PDM enters the Loss of Communication state.

CAN message sent to the HCPDM to energize the outputs.

Transmission Repetition	20 – 500 ms	
Data Length	3 bytes	
Data Page	0	
PDU Format (PF)	239	Proprietary A, PDU1 format
PDU Specific (PS)	40 (28h) or as set	DA (Source Address of the PDM)
Priority	5	
Parameter Group Number	61184 (EF00h)	

Start Position	Length	Parameter Name	Reference
1	1 byte	Output Command Identifier	4.4.2.1
2.1	1 bit	HS Out CH 1	4.4.2.2
3.1	1 bit	HS Out CH 2	4.4.2.2
4	1 byte	Not used (FF)	
5	1 byte	Not used (FF)	
6	1 byte	Not used (FF)	
7	1 byte	Not used (FF)	
8	1 byte	Not used (FF)	

4.4.2.1 Output Command Identifier

This value defines which output channels the Command Output Channels message is referencing.

Identifier: 9 Command High Side Output
Data Length: 1 byte
Resolution: NA 0 offset
Data Range: 9 Operational Range: same as data range
Type: Identifier
PGN: PGN 61184 – [Command Output Channels](#)

4.4.2.2 HS Out CH command

This value defines whether the specified channel is enabled or disabled. There are 2 available channels

0 Off
1 On

Data Length: 1 bit
Resolution: 2 states / 1 bit 0 offset
Data Range: 0 or 1 Operational Range: same as data range
Type: Status (command)
PGN: PGN 61184 – [Command Output Channels](#)

4.5 Feedback and Diagnostics

The HCPDM will periodically transmit feedback messages with the measured analog values and handshake.

The following message type defines how to interpret information received from the HCPDM:

- [Analog Inputs Feedback](#)
- [Diagnostics Outputs 1 - 8](#)
- [HCPDM Status](#)
- [Feedback](#)
- [Motor Model Handshake](#)
- [Output Configuration Handshake](#)

4.5.1 Analog Inputs Feedback

The analog channel feedback is the 16 bit value of the input signal on the respective channel with 10 bit resolution. There are 2 messages (128 & 129) that support the 6 channels

CAN message sent by the HCPDM to communicate the measured values.

Transmission Repetition	50 ms minimum (5x the base rate)	
Data Length	8 bytes	
Data Page	0	
PDU Format (PF)	239	Proprietary A, PDU1 format
PDU Specific (PS)	17 (11h)	DA (Source Address of the configuring display or controller)
Priority	5	
Parameter Group Number	61184 (EF00h)	

Start Position	Length	Parameter Name	Reference
1	1 byte	Feedback and Diagnostics Identifier	0
2	1 byte	Analog CH 1 or 4 LSB	4.5.1.2
3	1 byte	Analog CH 1 or 4 MSB	4.5.1.2
4	1 byte	Analog CH 2 or 5 LSB	4.5.1.2
5	1 byte	Analog CH 2 or 5 MSB	4.5.1.2
6	1 byte	Analog CH 3 or 6 LSB	4.5.1.2
7	1 byte	Analog CH 3 or 6 MSB	4.5.1.2
8	1 byte	Not used FF	

Regardless of the Source Address of the configuring and controlling device, that device must listen for feedback messages addressed to Source Address 17 (11h).

4.5.1.1 Feedback and Diagnostics Identifier

All feedback and diagnostic messages contain a unique identifier which determines the associated information.

- 128 (80h) Analog Inputs 1-3
- 129 (81h) Analog Inputs 4-6
- 130 (82h) Diagnostics 1-8
- 131 (83h) SW version, power supply status, 5V status, battery voltage
- 132 (84h) Outputs 1-4 Feedback
- 133 (85h) Outputs 5-8 Feedback
- 134 (86h) Motor Model Handshake
- 135 (87h) Output Configuration Handshake Channels 1-4
- 136 (88h) Output Configuration Handshake Channels 5-8

Data Length: 1 byte
Resolution: 1 state / 1 byte 0 offset
Data Range: 0 Operational Range: same as data range
Type: Status (command)
PGN: PGN 61184 – [Feedback and Diagnostics](#)

4.5.1.2 Analog Inputs

Each analog input is represented by a 16-bit value. The associated engineering units are dependent upon the configuration of the input. Note that the input range exceeds the limits of what the inputs are capable of handling in some instances.

LSB (8 bits)
MSB (8 bits)

Data Length: 2 bytes
Resolution: 12 bits 0 offset
Data Range: 0-65535, 0 or 1 Operational Range: same as data range
Type: Status (command)
PGN: PGN 61184 – [Feedback and Diagnostics](#)

Voltage: millivolts, 0 – 65535 mV (dynamic range adjustment between 5V & 32V range)
Current: microamps, 0 – 65535 μ V
Resistance: Ω 0 – 65535 Ω (dynamic range adjustment using 1k Ω & 22.1k Ω pull-up resistors to 5VDC)
Digital High Side: 1 = input grounded
Digital Low Side: 1 = input tied to Vbatt

4.5.2 Diagnostics Outputs 1 - 8

The output diagnostics indicate: no fault, a short-circuit, an over-current condition, or an open-circuit on each of the 8 high current outputs.

CAN message sent by the HCPDM to communicate the status of the individual outputs.

Transmission Repetition	20 – 500 ms	
Data Length	8 bytes	
Data Page	0	
PDU Format (PF)	239	Proprietary A, PDU1 format
PDU Specific (PS)	17 (11h)	DA (Source Address of the configuring display or controller)
Priority	5	
Parameter Group Number	61184 (EF00h) - Feedback and Diagnostics	

Start Position	Length	Parameter Name	Reference
1	1 byte	Feedback and Diagnostics Identifier	4.5.1.1
2.7	2 bits	Output 1 Diagnostic	4.5.2.1
2.5	2 bits	Output 2 Diagnostic	4.5.2.1
2.3	2 bits	Output 3 Diagnostic	4.5.2.1
2.1	2 bits	Output 4 Diagnostic	4.5.2.1
3.7	2 bits	Output 5 Diagnostic	4.5.2.1
3.5	2 bits	Output 6 Diagnostic	4.5.2.1
3.3	2 bits	Output 7 Diagnostic	4.5.2.1
3.1	2 bits	Output 8 Diagnostic	4.5.2.1
4	1 byte	Unused FF	
5	1 byte	Unused FF	
6	1 byte	Unused FF	
7	1 byte	Unused FF	
8	1 byte	Unused FF	

4.5.2.1 Output Diagnostic

Output channel diagnostic status.

- 00 No faults
- 01 Short-circuit
- 10 Over-current
- 11 Open-circuit

Data Length: 2 bits
Resolution: 4 states / 2 bits 0 offset
Data Range: 0-3 Operational Range: same as data range
Type: Status (measured)
PGN: PGN 61184 – Feedback and Diagnostics

4.5.3 HCPDM Status

The HCPDM Status message includes the following: Power supply status, Battery voltage measurement, 5V supply status, and software revision.

CAN message sent by the HCPDM to communicate the status and measured value.

Transmission Repetition	20 – 500 ms	
Data Length	8 bytes	
Data Page	0	
PDU Format (PF)	239	Proprietary A, PDU1 format
PDU Specific (PS)	17 (11h)	DA (Source Address of the configuring display or controller)
Priority	5	
Parameter Group Number	61184 (EF00h) - Feedback and Diagnostics	

Start Position	Length	Parameter Name	Reference
1	1 byte	Feedback and Diagnostics Identifier	4.5.1.1
2.1	1 bit	Power supply status total current too high	4.5.3.1
2.2	1 bit	Power supply status OK	4.5.3.1
3	1 byte	Software revision LSB	4.5.3.2
4	1 byte	Software revision MSB	4.5.3.2
5.1	1 bit	5V supply status too low	4.5.3.3
5.2	1 bit	5V supply status too high	4.5.3.3

6	1 byte	Battery voltage LSB	4.5.3.4
7	1 byte	Battery voltage MSB	4.5.3.4
8	1 byte	Unused FF	

4.5.3.1 Power Supply Status

This bit monitors the total current consumption of the HCPDM.

- 0 Total current is too high
- 1 Total current is OK

Data Length: 1 bit
Resolution: 1 0 offset
Data Range: 0-1 Operational Range: same as data range
Type: Status
PGN: PGN 61184 – [Feedback and Diagnostics](#)

This bit indicates the power supply is functioning correctly.

- 0 Power supply is not OK
- 1 Power supply is OK

Data Length: 1 bit
Resolution: 1 0 offset
Data Range: 0-1 Operational Range: same as data range
Type: Status
PGN: PGN 61184 – [Feedback and Diagnostics](#)

4.5.3.2 Software Revision

The software version number is represented by a 16 bit value.

Data Length: 2 bytes
Resolution: - 0 offset
Data Range: - Operational Range: same as data range
Type: Status (measured)
PGN: PGN 61184 – Feedback and Diagnostics

4.5.3.3 5V Supply Status

This bit monitors the 5V supply voltage.

- 0 Voltage is too low
- 1 Voltage is OK

Data Length: 1 bit
Resolution: 1 0 offset
Data Range: 0-1 Operational Range: same as data range
Type: Status
PGN: PGN 61184 – [Feedback and Diagnostics](#)

This bit also monitors the 5V supply voltage

- 0 Voltage is too high
- 1 Voltage is OK

Data Length: 1 bit
Resolution: 1 0 offset
Data Range: 0-1 Operational Range: same as data range
Type: Status
PGN: PGN 61184 – [Feedback and Diagnostics](#)

4.5.3.4 Battery Voltage

The measured value of the battery voltage.

Data Length: 2 bytes
Resolution: 10 bits (62.5mV/bit) 0 offset
Data Range: 0-63.999 V Operational Range: same as data range
Type: Status (measured)
PGN: PGN 61184 – [Feedback and Diagnostics](#)

4.5.4 Feedback

CAN message sent by the HCPDM to communicate output feedback measurement. The output feedback is the 8 bit value of the output measurement on the respective channel with 8 bit resolution. There are 2 messages (132 & 133) that support the 8 channels.

WARNING: Closed-loop proportional control is not recommended due to the limited measurement precision and non-deterministic nature of the CAN bus.

Transmission Repetition	20 – 500 ms	
Data Length	8 bytes	
Data Page	0	
PDU Format (PF)	239	Proprietary A, PDU1 format
PDU Specific (PS)	17 (11h)	DA (Source Address of the configuring display or controller)
Priority	5	
Parameter Group Number	61184 (EF00h) - Feedback and Diagnostics	

Start Position	Length	Parameter Name	Reference
1	1 byte	Feedback and Diagnostics Identifier	4.5.1.1
2	1 byte	Output Feedback CH 1 or 5	4.5.4.1
3	1 byte	Output Feedback CH 2 or 6	4.5.4.1
4	1 bytes	Output Feedback CH 3 or 7	4.5.4.1
5	1 byte	Output Feedback CH 4 or 8	4.5.4.1
6	1 byte	Not used FF	
7	1 byte	Not used FF	
8	1 byte	Not used FF	

4.5.4.1 Current, Power, Position or Rate Feedback

Note: Current feedback is supported. Position feedback is a special use case intended for the marine market.

Current Feedback: resolution of 0.125 A / LSB (0 – 31A)
 Power Feedback: 1 W / LSB (Not supported)
 Position Feedback: 1% / LSB, offset 75%, range of -75 to 180%
 Rate Feedback: 0.25 % / sec / LSB, range 0 to 63.75% (Not supported)

Data Length: 1 byte
Resolution: See above 0 offset
Data Range: See above Operational Range: same as data range
Type: Status (measured)
PGN: PGN 61184 – [Feedback and Diagnostics](#)

4.5.5 Motor Model Handshake

The handshake message is sent back every time a configuration message is received as an acknowledgement of the output channel setup. The handshake message is also sent once per second thereafter for a means of checking the output configuration.

CAN message sent by the HCPDM to communicate the output channel number, soft-start parameters, motor/lamp mode, loss of communication and other output controls.

Transmission Repetition On receipt of configuration message or 1,000 ms
Data Length 8 bytes
Data Page 0
PDU Format (PF) 239 Proprietary A, PDU1 format
PDU Specific (PS) 17 (11h) DA (Source Address of the configuring display or controller)
Priority 5
Parameter Group Number 61184 (EF00h) - [Feedback and Diagnostics](#)

Start Position	Length	Parameter Name	Reference
1	1 byte	Feedback and Diagnostics Identifier	4.5.1.1
2	1 byte	Channel Number	4.3.1.2
3	1 byte	Soft-Start Step Size	4.3.1.3
4	1 byte	Motor/Lamp Mode	4.3.1.4
5	1 byte	Loss of Communication	4.3.1.5

6	1 byte	Command Mode	4.3.1.6
7.4	5 bits	Power On Reset Command	4.3.1.7
7.3	1 bit	Power On Reset Enable	4.3.1.8
7.2	1 bit	Command Type	4.3.1.9
7.1	1 bit	Motor Braking	4.3.1.10
8.5	4 bits	Digital Input	4.3.1.11
8.3	2 bits	Calibration Time	4.3.1.12
8.1	2 bits	Response	4.3.1.13

4.5.6 Output Configuration Handshake

After the output channels settings are sent to the HCPDM, the stored settings are then broadcast back to the configuring device in order to verify the intended configuration. Only after the settings are in agreement should the output be enabled.

CAUTION: Use this message to verify the output settings prior to enabling any output.

This CAN message is broadcast by the HCPDM to communicate the settings of a group of output channels. Depending on the Feedback and Diagnostics Identifier byte, the message pertains to Output Channels 1-4 or 5-8 respectively.

Transmission Repetition	20 – 500 ms	
Data Length	8 bytes	
Data Page	0	
PDU Format (PF)	239	Proprietary A, PDU1 format
PDU Specific (PS)	17 (11h)	DA (Source Address of the configuring display or controller)
Priority	5	
Parameter Group Number	61184 (EF00h) - Feedback and Diagnostics	

Start Position	Length	Parameter Name	Reference
1	1 byte	Feedback and Diagnostics Identifier (135 or 136)	4.5.1.1
2.5	4 bits	Current Limit (Output Channel 1 or 5)	4.3.2.2
2.3	2 bits	Feedback Type (Output Channel 1 or 5)	4.3.2.3
2.2	1 bit	Automatic Reset (Output Channel 1 or 5)	4.3.2.3
2.1	1 bit	High-Side or H-Bridge (Output Channel 1 or 5)	4.3.2.5
3.5	4 bits	Current Limit (Output Channel 2 or 6)	4.3.2.2
3.3	2 bits	Feedback Type (Output Channel 2 or 6)	4.3.2.3
3.2	1 bit	Automatic Reset (Output Channel 2 or 6)	4.3.2.3
3.1	1 bit	High-Side or H-Bridge (Output Channel 2 or 6)	4.3.2.5
4.5	4 bits	Current Limit (Output Channel 3 or 7)	4.3.2.2
4.3	2 bits	Feedback Type (Output Channel 3 or 7)	4.3.2.3
4.2	1 bit	Automatic Reset (Output Channel 3 or 7)	4.3.2.3
4.1	1 bit	High-Side or H-Bridge (Output Channel 3 or 7)	4.3.2.5
5.5	4 bits	Current Limit (Output Channel 4 or 8)	4.3.2.2
5.3	2 bits	Feedback Type (Output Channel 4 or 8)	4.3.2.3

This CAN message is broadcast by the HCPDM to communicate the settings of a group of output channels. Depending on the Feedback and Diagnostics identifier byte, the message pertains to Output Channels 1-4 or 5-8 respectively.

Transmission Repetition	20-500ms	
Data Length	8 bytes	
Data Page	0	
PDU Format (PF)	239	Proprietary A, PDU1 format
PDU Specific (PS)	17 (11h)	DA (Source Address of the configuring display or controller)
Priority	5	
Parameter Group Number	61184 (EF00h)	Feedback and Diagnostics

Start Position	Length	Parameter Name	Reference
5.2	1 bit	Automatic Reset (Output Channel 4 or 8)	4.3.2.3
5.1	1 bit	High-Side or H-Bridge (Output Channel 4 or 8)	4.3.2.5
6	1 byte	Not used FF	
7	1 byte	Not used FF	

Start Position	Length	Parameter Name	Reference
8	1 byte	Reserved (always FFh)	

4.6 Example Messages

4.6.1 Arbitration Field

The HCPDM follows SAE J1939-21, which defines proprietary Parameter Group Numbers (PGNs). The Protocol Data Unit (PDU) is the bit arbitration field of every message on the CAN bus.

The first three bits are the Priority (P) of the message. The recommended value is 5h (5). When combined with the Reserved (R) bit and Data Page (DP) bit, the value becomes 14h (20).

NOTE: Your application may require adjusting the priority based on other devices on the CAN bus.

The PDU1 format is followed, and the PDU Format (PF) is always set to EFh (239), which is reserved for proprietary use.

The PowerView display or CAN bus controller sends messages to the PDM at Destination Address 28h (40), which is the same as the PDM Source Address.

The PDM broadcasts messages to Destination Address 11h (17) regardless of the actual Source Address of the PowerView display or CAN bus controller.

The resulting arbitration headers of the messages sent to and from the PDM would look like the following.

J1939 29 bit Identifier (Arbitration field)

J1939	SOF	ID (11 bits)											SRR	SRR	IDE	IDE	ID Extension (18 bits)																	RTR															
		Priority	R	DP	PDU Format				PF	DA							SA																																
Frame Format	1	2	3	2	1	5	6	7	8	7	6	5	4	3	2	1	16	15	14	13	12	11	10	9	8	7	6	5	4	3	2	1	30	29	28	27	26	25	24	23	22	21	20	19	18	17	33		
29 Bit ID Position		28	27	26	25	24	23	22	21	20	19	18	17	16	15	14	13	12	11	10	9	8	7	6	5	4	3	2	1	30	29	28	27	26	25	24	23	22	21	20	19	18	17	33					
Message Sent		14h				EFh (239)											28h (40)							11h (17)																									
to PDM	1	0	1	0	0	0	0	1	1	1	1	1	1	1	1	1	0	0	1	0	1	0	0	0	0	0	0	0	0	0	0	0	0	0	0	0	0	0	0	0	0	0	0	0	0	0	0	1	
Message Sent		14h				EFh (239)											11h (17)							28h (40)																									
from PDM	1	0	1	0	0	0	1	1	1	1	1	1	1	1	1	1	0	0	0	0	1	0	0	0	1	0	0	1	0	0	0	0	0	0	0	0	0	0	0	0	0	0	0	0	0	0	0	0	0

The eight data bytes from the various PGNs follow the respective header.

4.7 Example Pseudo Code

These are example program flows to configure, command and read the feedback messages.

4.7.1 Configure and Verify Outputs

The following pseudo code outlines the possible steps to take in configuring the PDM:

```
FOR Outputs 1-8
    CONFIGURE Output n function
    READ Output n function handshake
    VERIFY Output n function
ENDFOR

FOR Output Groups 1-4 and 5-8
    CONFIGURE Output Group
    READ Output Config Handshake Message
ENDFOR
```

4.7.2 Command Outputs

The following pseudo code outlines the possible steps to command the PDM:

```
SEQUENCE
    COMMAND Outputs 1-4
    COMMAND Outputs 5-8

    READ AI 1-3
    READ AI 4-6
    READ Diagnostics
    READ HCPDM Status
    READ Outputs 1-4 Feedback
    READ Outputs 5-8 Feedback

    IF Error
        Take Action
    ENDIF
```

4.7.3 Read Diagnostics

```
SEQUENCE
    READ AI 1-2 and DIs
    READ AI 3-4 and Output Diagnostics
    READ AI 5-6 and Supplies
    READ AI 7-8
```

5 Troubleshooting

5.1 Output Does Not Respond

Check the battery or power supply connection.

Check the power supply rating.

- The HCPDM switches a high amount of current. Many power supplies are incapable of sourcing adequate current. Using a battery is the preferred method for powering the HCPDM.

Check the CAN bus and messaging.

5.2 HCPDM Does Not Function

Check the battery or power supply connection.

Check the external circuit breaker or fuse.

Check the power supply connection to the HCPDM.

- Verify by connecting a voltmeter to the 5V Sensor Supply and determine if the unit has power. If the Sensor Supply is not providing 5V, continue to next step.

HCPDM has been damaged.

- If the HCPDM is subjected to an extreme over-current event and has no response, replace the unit.

6 Specifications

Operating Voltage:

12V nominal (6 -16 V)
Reverse polarity protection

Operating Current:

Total: 200 A, simultaneous active outputs
Standby (idle) current draw: <170 mA typical (current consumed when no outputs are driven).
Sleep current draw: < 2 mA typical (sleep occurs after 20 minutes with no CAN communications and no outputs driven when configured for wake on CAN).

Inputs:

Analog:

6 analog support for voltage (0 – 5 VDC or 0 – 32 VDC dynamically adjusted), current (4 – 20mA), resistive (1 k Ω or 22.1k Ω dynamically adjusted pull-up to 5 V), digital high side, and digital low side. These inputs have 12 bit resolution

Outputs:

8 Digital High current (40 A maximum each, 200 A total)
Configurable as high-side switch, open-loop PWM or up to 4 H-bridge pairs
PWM frequency: 500 Hz
Maximum off state leakage current: <0.1 mA
Open Load Detection: 0.2 A minimum, 0.5 A typical
2 Digital high-side (100 mA each), these are crank ride through protected

Sensor Supply: 5 VDC at 400 mA

LED Indicators: 3 – Green (power status), Red (active fault), Blue (communications)

Ignition/sleep pin: Control of wake & sleep function, optionally configurable to wake on CAN

CAN Interface: CAN 2.0B Active, SAE J1939 Proprietary A messaging, 250 kbps

Housing: E-coated cast aluminum enclosure with plastic connectors

Dimensions: 350 mm (L) x 192 mm (W) x 69 mm (H)

Weight: 8.136 lbs (3694 gram)

Mating Connectors: Inputs: CAN, & Sensor Supply: One 18 way TE 934457151
Outputs: Four 2 way DTE 1355328-1
Power Supply: Two female threaded lugs with Cross-Head Hex bolts (1 M8 for – and 1 M12 for +)

Environmental Ratings & Testing:

Operating Temperature: -40°C to +85°C (-40°F to +185°F)

Storage Temperature: -40°C to +105°C (-40°F to +221°F)

Ingress Protection: IP 67 & 69K

Dust: SAE J1455 Section 4.7.3 IEC529

Shock: SAE J1455 Section 4.10.4.6, 6 pulses (+/-50 G, 6ms on each axis)

Vibration: ISO 16750-3 Section 4.1.2.7 Random 5.82G, 8 hours/axis

Transit shock: SAE J1455 Section 4.11.3.2 Test of HCPDM shipment packaging

Handling drop: SAE J1455 Section 4.11.3.1, 1 meter drop on concrete each of 6 box faces

Initial conditioning: 24 hours @ -40°C, 48 hours @ +105°C

Ignition cycling: 10,000 cycles @ maximum supply voltage

Thermal shock: SAE J1455 Section 4.1.3.2 5 cycles of 2 hours at -40°C and 2 hours at +105°C

Humidity/temperature cycling: SAE J1455 Section 4.2.3, 36 six hour cycles of -50°C to 90°C @ 90% RH

High temperature endurance: +125°C for 200 hours unpowered followed full function test

Tri-temperature functional: Single 24 hour cycle from -40°C to +105°C

Brine ingestion: 8 cycles of 1 hour @ 105°C followed by 1 hour @ 13°C

Ice: 3 cycles stabilize @ -20°C, submerge in 0°C, then -20°C

Salt fog: ASTM B117 96 hours @ 35°C in 5% NaCl

Steam clean: 5.7liter/min 2.41 MPa 20 – 30 cm for 375 cycles

Fluid compatibility: SAE J1455 Section 4.4.1

Hot plugging: 5 connection/disconnection cycles while powered

Maximum voltage: Power with maximum rated voltage for 168 hours @ +105°C

Electrical Testing:

General:

Power up and 24 hour operation at extreme temperature

ISO 16750-2 Jump start forward & reverse voltage

ISO 16750-2 Short circuit protection power outputs & signal lines

Immunity:

ISO 16750-2 test 4.3 Full field alternator

SAE J1113-4 Bulk current Injection

SAE J1113-11 Pulse 1 Supply disconnection from inductive loads

SAE J1113-11 Pulse 2a Interruption of current in an inductive harness due to load disconnection

SAE J1113-11 Pulse 2b Transient from DC motor acting as generators

SAE J1113-11 Pulse 3a Negative switching spikes

SAE J1113-11 Pulse 3b Positive switching spikes
SAE J1113-12 Pulse 2a Negative slow transient
SAE J1113-12 Pulse 2b Positive slow transient
SAE J1113-12 Pulse 3a Negative fast transient
SAE J1113-12 Pulse 3b Positive fast transient
SAE J1113-12 Chattering relay coupled to signal lines
SAE J1113-12 Chattering relay loop antenna
SAE J1113-13 ESD powered
SAE J1113-13 ESD unpowered
SAE J1113-26 Radiated immunity – AC electric fields from power lines
ISO 16750-2 Pulse 4 Starter motor engagement disturbance
ISO 16750-2 Pulse 5a Load dump unsuppressed @ 4Ω
ISO 11452-2 ALSE with ground plane
ISO 11452-8 Radiated immunity magnetic fields (in-house environmental field)
ISO 11452-8 Radiated immunity magnetic fields (external field)
ISO 11452-9 Radiated immunity portable transmitters
ISO 11452-10 Conducted immunity on power leads
EN 61000-4-2 ESD powered direct & indirect
EN 60945 & EN 61326-1 ESD
EN 60945 & EN 61326-1 Radiated immunity
EN 60945 & EN 61326-1 Fast transients – power lines
EN 60945 & EN 61326-1 Fast transients – signal lines
EN 60945 & EN 61326-1 Conducted immunity – surge on power lines
EN 60945 & EN 61326-1 Conducted immunity – RF disturbance
EN 61326-1 Magnetic immunity

Emissions:

CISPR 25 Section 6.2 Conducted emissions – power lines
CISPR 25 Section 6.3 Conducted emissions – signal lines
CISPR 25 Section 6.4 Radiated emissions
EN 60945 Conducted emissions
EN 60945 Sec. 9.3 / CISPR 11 Class A Radiated emissions
ISO 13766-1 Radiated emissions – broadband
ISO 13766-1 Radiated emissions – narrowband

7 Condensed Message & Byte Definition

Message Definitions								
PDM Rx Message Name	Byte 1	Byte 2	Byte 3	Byte 4	Byte 5	Byte 6	Byte 7	Byte 8
Configuration Motor Model	0 (0x00)	Channel #	Soft Start Step Size	Motor/Bulb Mode	Loss of Comm	Command Mode	Brake_Cmd, POR	Switch Control
Command CH1-4	4 (0x04)	Command CH1	Command CH2	Command CH3	Command CH4	Not Used	Not Used	Enable Bits CH 1-4
Command CH5-8	5 (0x05)	Command CH5	Command CH6	Command CH7	Command CH8	Not Used	Not Used	Enable Bits CH 5-8
Configuration CH 1-4	6 (0x06)	Configuration CH 1	Configuration CH 2	Configuration CH 3	Configuration CH 4	Not Used	Not Used	FF
Configuration CH 5-8	7 (0x07)	Configuration CH 5	Configuration CH 6	Configuration CH 7	Configuration CH 8	Not Used	Not Used	FF
Configuration Analog CH 1-6	8 (0x08)	Configuration CH1	Configuration CH2	Configuration CH3	Configuration CH4	Configuration CH5	Configuration CH6	FF
Command High Side Output	9 (0x09)	HS Out Ch1	HS Out Ch2	Not Used	Not Used	Not Used	Not Used	Not Used
Configuration MISC	10 (0x0A)	Sensor Supply	Sensor Supply Enable	Ignition Enable				
Configuration Position	11(0x0B)	Channel #	Position Hysteresis	Stalled Resistance LSB	Stalled Resistance MSB	Gain LSB	Gain MSB	Position (0-100%)
PDM Tx Message Name, Byte 1	Byte 2	Byte 3	Byte 4	Byte 5	Byte 6	Byte 7	Byte 8	
Analog 1-3	128	CH 1 LSB	CH 1 MSB	CH 2 LSB	CH 2 MSB	CH 3 LSB	CH 3 MSB	
Analog 4-6	129	CH 4 LSB	CH 4 MSB	CH 5 LSB	CH 5 MSB	CH 6 LSB	CH 6 MSB	
Diagnostic 1-8	130	Diagnostic CH1-4	Diagnostic CH 5-8					
SW Ver, PS Stat, SV Stat, Battery Vc	131	Power Supply Status	Software Rev LSB	Software Rev MSB	SV Status	Battery Voltage LSB	Battery Voltage MSB	
Feedback CH 1-4	132	Feedback CH 1	Feedback CH 2	Feedback CH 3	Feedback CH 4	Not Used	Not Used	FF
Feedback CH 5-8	133	Feedback CH 5	Feedback CH 6	Feedback CH 7	Feedback CH 8	Not Used	Not Used	FF
Motor Model Handshake	134	Channel #	Soft Start Step Size	Motor/Bulb Mode	Loss of CAN	Command Mode	Brake_Cmd, POR	Switch Control
CH1-4 Config Handshake	135	Configuration CH 1	Configuration CH 2	Configuration CH 3	Configuration CH 4			FF
CH5-8 Config Handshake	136	Configuration CH 5	Configuration CH 6	Configuration CH 7	Configuration CH 8			FF

NOTE: Packets 128-131 are sent 5x the base rate (50 msec @ the fastest rate), Packets 132-133 are sent at 10x the base rate, Packets 134-136 are set at boot and thereafter at 1 Hz or after a configuration change is received.

Byte Definitions								
Byte Name	Bit 8	Bit 7	Bit 6	Bit 5	Bit 4	Bit 3	Bit 2	Bit 1
Brake_Cmd, POR (CH7_MCFG_cmd)			Power On Reset			POR Enable	Command Bit	Brake
Switch Control (CH7_SWSrc_cmd)		Dig In #			Cal Time		Response	
Enable Bits CH 1-4		PDM Tx Rate		Not Used, Always 11	Enable CH 4	Enable CH 3	Enable CH 2	Enable CH 1
Enable Bits CH 5-8		Not Used, Always 11		Not Used, Always 11	Enable CH 8	Enable CH 7	Enable CH 6	Enable CH 5
Configuration CH X		Overcurrent Shutdown Level				Feedback Type		H-Bridge
Diagnostic CH 1-4		Diagnostic Bits CH 1		Diagnostic Bits CH 2		Diagnostic Bits CH 3	Diagnostic Bits CH 4	
Diagnostic CH 5-8		Diagnostic Bits CH 5		Diagnostic Bits CH 6		Diagnostic Bits CH 7	Diagnostic Bits CH 8	
SV Status				Not Used, Always 111111			SV High	SV Low
Power Supply Status				Not Used, Always 111111			Power Supply OK	Current High

8 Condensed Message Variable Definition

Variable Definitions	
Variable Name	Definition
Brake	Braking for H-Bridge, 0 = Braking Disabled, 1 = Braking Enabled.
Power on Reset	Power On Reset Value, 5-bit signed, Resolution 6.25% / lsb, special case 01111 = 100% (see Table Power on Reset Key below)
POR Enabled	0 = POR Enabled, 1 = POR Disabled
Command Bit	1 = Loss of Can Feature Disabled, 0 = Loss of Can Feature Enabled (Recommended setting = 0)
Loss of Comm	Loss of Communication Setting, 00 = CH Unchanged (Last Comanded), 01 = CH -100% (H-Bridge Only), 10 = CH +100%, 11 = CH 0% (off).
Response	Response for Switch Source, 00 = No Response, 01 = Low Only, 10 = High Only, 11 = either High or Low.
Cal Time	Switch Source Cal Time, 0 = Override Fixed, 1 = Override Cal Time, always 0 for H-Bridge (ALWAYS 0)
Dig In #	Digital Input CH #, Range 0-5 (CH #1 = 0, CH #6 = 101)(If Switch Source Response > 0).
Normal/Cal Mode	1 = normal mode, 0 = calibration mode, position or switch commands disabled
Soft Start Step Size (CH?_pos)	0-100% (0-01111111); Resolution = .78125 % / LSB, Range - 0% thru 98.4375%, Special case = 01111111 = +100%, ignore if 0xFF
Motor/Bulb Mode CH X (CH?_TF_cmd)	1 = Motor Mode, 0 = Bulb Mode
PDM Tx Rate	PDM Tx Rate, 00 = 500ms, 01 = 250ms, 10 = 50ms, 11 = 10ms.
Enable CH X	Enable Output CH, 0 = Disabled, 1 = Enabled.
Command CH X (CH?_pos_cmd or CH?_PWM_input)	PWM Output Command, Resolution = .78125 % / LSB, Range -100% - 98.4375%, Special case = 01111111 = +100%. Position Command, 1% / LSB, range is 0 - 100 % NOTE: Command byte should be set to 0 for any channel whose Configure byte is set to 255 (either disabled or 2nd channel in H-Bridge pair)
H-Bridge	H-Bridge or High Side Drive, 0 = High Side Drive, 1 = H-Bridge .
Overcurrent Retry	Overcurrent Retry, 0 = Output will retry autonomously (5 retries before staying off then waits for off/on command transition), 1 = Output will stay off until off/on command transition.
Feedback Type	Feedback type, 00 = Position feedback, 01 = Rate feedback, 10 = Power feedback, 11 = Current feedback (ALWAYS 11)
Overcurrent Shutdown Level	Overcurrent shutdown level, 0 = 0.1 = 5A, 2 = 7.5A...15 = 40A. Range = 0 - 40A.
Configuration CH X	NOTE: Configure byte should be set to 255 is channel is to be disabled or is the 2nd channel in an H-Bridge pair
5V Low	5V Low, 0 = 5V Output Low, 1 = 5V Output OK(Not Low).
5V High	5V High, 0 = 5V Output High, 1 = 5V Output OK(Not High).
Current High	Total Current High, 0 = Total Current High, 1 = Total Current OK(Not High).
Power Supply OK	Power Supply, 0 = Power Supply Not OK, 1 = Power Supply OK.
Digital Input	Digital Input, 00 = Open Circuit, 01 = Short to Ground, 10 = Short to Battery, 11 = Not Available
Command Mode	0 = PWM, 1 = Position
Position Hysteresis	Percentage of position to use as hysteresis value. This value is a [4.4] number. Each lsb = 1/16
Position	Used to set position, 0-100%, 0xFF is ignored
Stalled Resistance	Stalled resistance of motor, used in conjunction with the gain to control position. 1/512/Ohm per bit. This value along with gain must be empirically tweaked to control position. There is no feedback, so the control is gross.
Gain	This number must be determined somewhat empirically to control position.
Diagnostic Bits CH X	Diagnostic Bits, 00 = No Faults, 01 = Short Circuit, 10 = Overcurrent, 11 = Open Circuit
Feedback CH X	Position Feedback, 1% / LSB, offset 75%, range -75 to 180% Rate Feedback, .25%/sec / LSB, range 0 to 63.75% Power Feedback, 1W / LSB Current Feedback, Resolution = 0.125A / lsb
Analog Ch 1-6	Voltage Input, millivolts, 0-65535 mV Current Input, uAmps, 0-65535 uA Resistance, Ohms 0-65535 Ohms Digital High - 1 indicates input grounded Digital Low - 1 indicates input tied to Vbatt
Sensor Supply	0 for 5V, 1 for 10V. Ignored on 12V version, always 5 V.
Sensor Supply Enable	1 for Enable 0 for Disable
Ignition Enable	0 Disables 1 Enables
Analog CH 1-6 Configuration	0 for Voltage In 1 For Current In 2 for resistance in 3 for digital high (digital input pulled high) 4 for digital low (digital input pulled low)
HS CH1 & CH2	0 for off, 1 for on
Battery Voltage	Millivolts

9 Power on Reset Key

Power On Reset Commands	Commanded PWM	Actual PWM
01111	93.75%	100%
01110	87.50%	87.50%
01101	81.25%	81.25%
01100	75.00%	75.00%
01011	68.75%	68.75%
01010	62.50%	62.50%
01001	56.25%	56.25%
01000	50.00%	50.00%
00111	43.75%	43.75%
00110	37.50%	37.50%
00101	31.25%	31.25%
00100	25.00%	25.00%
00011	18.75%	18.75%
00010	12.50%	12.50%
00001	6.25%	6.25%
00000	0.00%	0.00%
11111	-6.25%	-6.25%
11110	-12.50%	-12.50%
11101	-18.75%	-18.75%
11100	-25.00%	-25.00%
11011	-31.25%	-31.25%
11010	-37.50%	-37.50%
11001	-43.75%	-43.75%
11000	-50.00%	-50.00%
10111	-56.25%	-56.25%
10110	-62.50%	-62.50%
10101	-68.75%	-68.75%
10100	-75.00%	-75.00%
10011	-81.25%	-81.25%
10010	-87.50%	-87.50%
10001	-93.75%	-93.75%
10000	-100%	-100%

In order to consistently bring you the highest quality, full-featured products, we reserve the right to change our specifications and designs at any time. MURPHY products and the Murphy logo are registered and/or common law trademarks of Enovation Controls, LLC. This document, including textual matter and illustrations, is copyright protected by Enovation Controls, LLC, with all rights reserved. (c) 2023 Enovation Controls, LLC. A copy of the warranty may be viewed or printed by going to www.enovationcontrols.com/warranty

ENOVATION CONTROLS CORPORATE HEADQUARTERS
5311 S 122ND EAST AVENUE
TULSA, OK 74146

ENOVATION CONTROLS LTD. – UNITED KINGDOM
CHURCH ROAD LAVERSTOCK
SALISBURY SP1 1QZ UK

SUN MURPHY INTERNATIONAL TRADING (SHANGHAI) CO., LTD
815 ROOM, 6# BUILDING, 351 SIZHUAN ROAD
SONGJIANG DISTRICT, SHANGHAI 201601, CHINA

ENOVATION CONTROLS INDIA PVT. LTD.
PLOT NO. 146, SECTOR 10, PCNTDA
BHOSARI, PIMPRI CHINCHWAD
PUNE - 411026
MAHARASHTRA, INDIA

U.S. SALES & SUPPORT

PHONE: 918 317 4100
EMAIL: SALES@ENOVATIONCONTROLS.COM
WWW.ENOVATIONCONTROLS.COM

CONTACT US



INTERNATIONAL SALES & SUPPORT

EUROPE, MIDDLE EAST, AFRICA
PHONE: +44 1722 410055
EMAIL: EMEASALES@ENOVATIONCONTROLS.COM

CHINA
PHONE: +86 21 6237 5885
EMAIL: APACSALES@ENOVATIONCONTROLS.COM

INDIA
PHONE: +91 91581 37633
EMAIL: INDIASALES@ENOVATIONCONTROLS.COM



FM 28221 (Tulsa, OK - USA)
FM 29422 (UK)



1022QAP07 (India)