

# EMS Pro

## Engine Monitoring System Controller

The EMS PRO is a flexible all-in-one customizable unit that meets the needs of engine-driven pumping equipment applications.

The EMS PRO is a dedicated microprocessor-based, single-engine controller. It offers field-adjustable operating parameters that can be changed without the need for a computer. It is also able to support both mechanical and J1939 electronic engines.

The EMS PRO has selectable auto start/stop features with several throttling options. The auto start/stop options (single contact, floats, momentary, transducer and clock) are available at the touch of a button. The transducer start/stop option includes three settings: pressure, level and temperature. In addition, there are many performance-enhancing features, all of which are available through an operator interface that is easy to learn and use. The EMS PRO is ideal for use with a remote modem or in a SCADA system offering MODBUS RTU protocol on either the RS232 or RS485 port.

The EMS PRO has the ability to withstand a wide ambient temperature range, comes standard in a NEMA 4 rated enclosure and is secured by four rubber shock mounts. Inside is a backlit graphical display that is visible day or night in all conditions.

Additional features include:

- Shut-down history file
- First-out shutdowns and/or alarm indicating LEDs
- Supports TSC1 throttle messaging
- Wide operating temperature range
- IP66 rated
- Internet ready utilizing MODBUS RTU with auxiliary equipment
- Real-time clock in 24-hour format
- NEMA 4 enclosure with optional clear door

### Communications

The EMS PRO has RS485, RS232 and J1939 CAN communication ports. The standard unit uses RS485 or RS232 for MODBUS RTU. At the same time, the CAN port allows J1939 communication with the engine ECU to display engine parameters and control the throttle via TSC1, if supported by the engine.

Shown  
with optional  
clear door.



\*Approved by CSA for Non-hazardous locations (Group Safety Publication IEC 61010-1)

### Specifications

**Operating Voltage (12 and 24 systems):** 8 VDC minimum to 32 VDC maximum

#### Environmental

**Operating Temperature:** -40° to 176°F (-40° to 80°C)

**NOTE:** Care should be taken when selecting the clear door option when used in applications involving sunlight exposure. Direct sunlight can cause premature component failure by allowing the sealed enclosure temperature to exceed the rated 80°C/175°F.

**Storage Temperature:** -40° to 176°F (-40° to 80°C)

**Environmental Sealing:** IP66

**NOTE:** Meets IP66 when the door is closed and latched.

**Relative Humidity:** 95%RH @ 60°C

**Standby Current:**

(@ 12VDC) 220mA

(@ 24VDC) 255mA

**CAN bus:** SAE J1939 compliant

**Enclosure:** Polycarbonate NEMA 4 (UL Certified)

#### Inputs

**Analog Inputs:** (12) designated via program; sender/ground digital, 4 -20mA, 0-5 VDC.

**Digital Inputs:** (8) high/low

**Frequency:** 1 optically-isolated input for speed reference, magnetic pick-up. (2VAC-50VAC RMS)

**Fuel Sender Input:** 33 Ohm full, 240 Ohm empty

#### Outputs

**Digital Outputs:** (3) FET B+ (rated at 1A)

**Relays:** 1 SPDT and 8 SPST 5 Amp pilot relays (maximum relay ground current limited to 23 amps).

**User Interface:** (8) button membrane switch

**Connectors:** 21 pin and 31 pin Deutsch HDP20 Series

**Mounting:** 4 isolated .75 inch rubber shock mounts

**Shipping Weight:** 11 lb. (5 kg.)

**Shipping Dimensions (all models):** 15 x 15 x 11 in. (381 x 381 x 279.4 mm)

# Dimensions

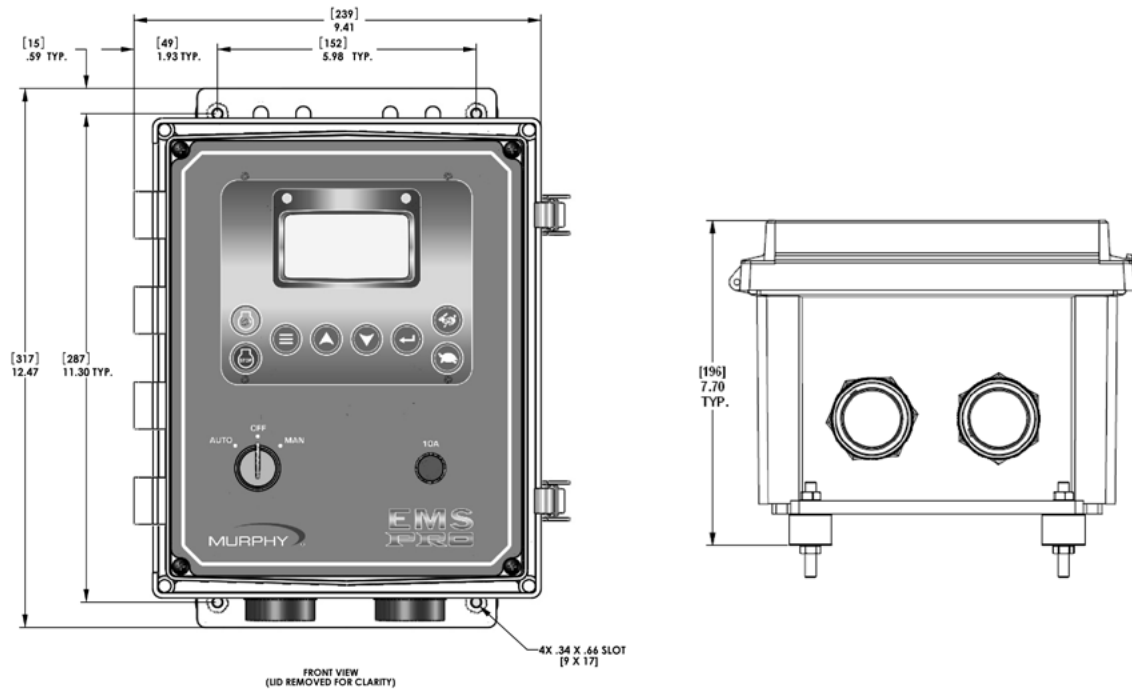

# How to Order

Part Number	Description	Notes
40700301	EMS Pro	
40700302	EMS Pro with optional clear door*	
40000479	21-pin and 31-pin connector kit	Accessories
40000480	Deutsch HDP 10' 21-pin and 31-pin harness kit	
40000481	10' 31-pin I/O harness	
Contact Industrial Panel Sales	MIH	
	MIH harness	

\* Care should be taken when selecting the optional clear door when used in applications involving direct sunlight exposure. Direct sunlight can cause premature component failure by allowing the sealed enclosure temperature to exceed the rated 175°F/80°C.