



by **ENOVATION** CONTROLS



PowerView[®] Model PV1200

Installation Manual

00-02-1021
2019-04-24
Section 78

In order to consistently bring you the highest quality, full-featured products, we reserve the right to change our specifications and designs at any time. The latest version of this manual can be found at enovationcontrols.com.

Warranty - A limited warranty on materials and workmanship is given with this Murphy product. A copy of the warranty may be viewed or printed by going to www.enovationcontrols.com/warranty



Please read the following information before installing.

BEFORE BEGINNING INSTALLATION OF THIS MURPHY PRODUCT:

Read and follow all installation instructions.

Please contact Enovation Controls immediately if you have any questions.

Table of Contents

Hardware Installation.....	5
Inspecting Package Contents.....	5
Dash-Mounted Installation.....	5
Preparing the Dash.....	6
Mounting the Unit.....	7
Available Accessories for the PV1200.....	7
Wiring Information	8
Pinout Specifications.....	8
Configuration Information	10
Wiring Schematics – Black Connector	12
Wiring Schematics – Gray Connector	13
Specifications	14
Dimensions	16

THIS PAGE INTENTIONALLY LEFT BLANK

Hardware Installation

The following instructions will guide you through installing the PowerView display.

Inspecting Package Contents

Before attempting to install the product, it is recommended that you ensure all parts are accounted for and inspect each item for damage (which sometimes occurs during shipping). The items included in the box are:

- PV1200 unit
- Installation manual web reference insert

Dash-Mounted Installation

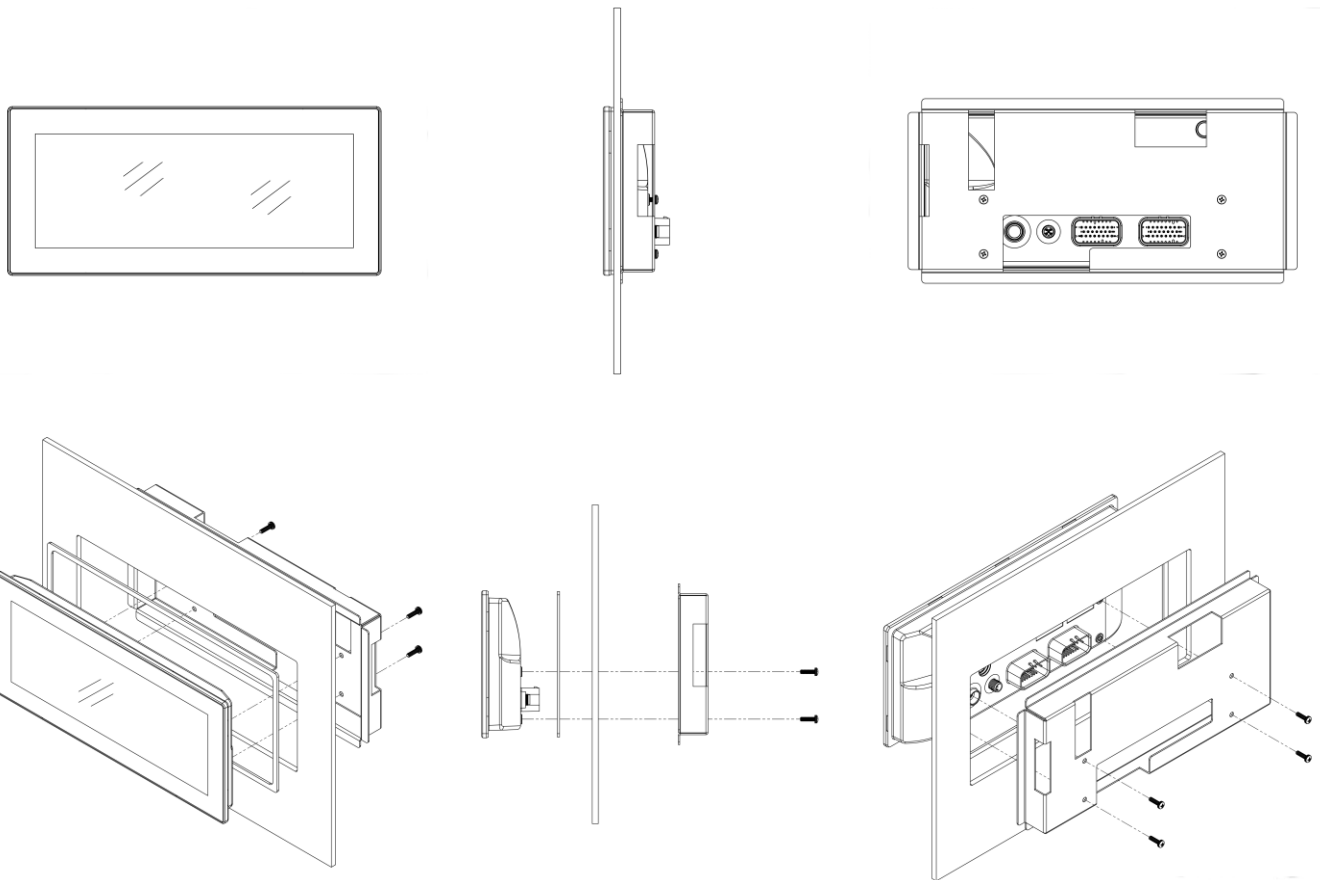

Installation Kit – P/N 78-00-1294 includes

- Bracket
- Panel Seal
- Four 8-32 machine screws

Tools needed.

- Drill with 7/32 in. size bit
- Jigsaw
- Screw Driver

Preparing the Dash

Determine the location of the PV1200 in the dash. Cut a hole in the dash to these dimensions: (For actual cutout template, see support.enovationcontrols.com, then search for PV1200)

- (recessed mounting): 13.1" x 5.62" (332.74 mm x 142.74 mm)

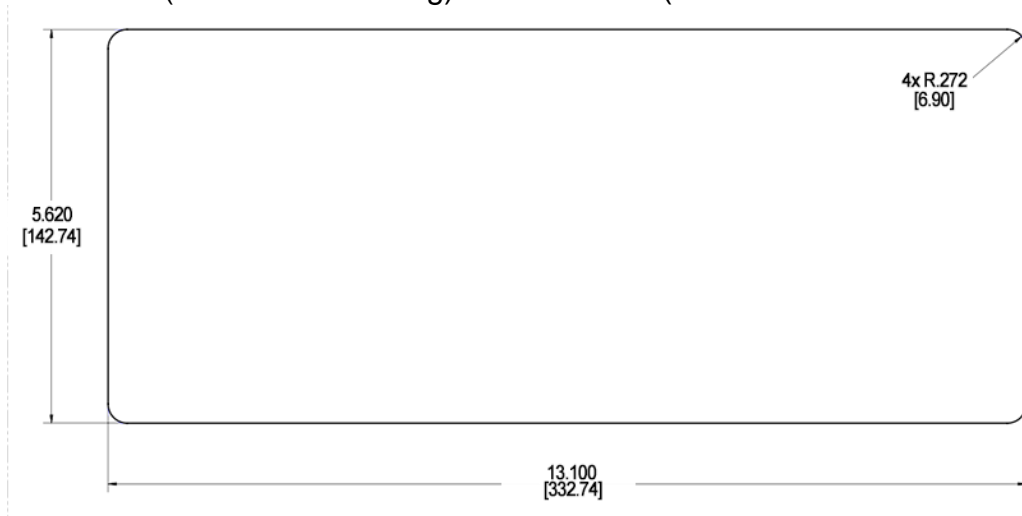

RECESSED MOUNT PANEL CUTOUT DIMENSIONS
FULL SCALE

- (surface mounting): 7.480 x 1.575 (190.00 mm x 40.00 mm)

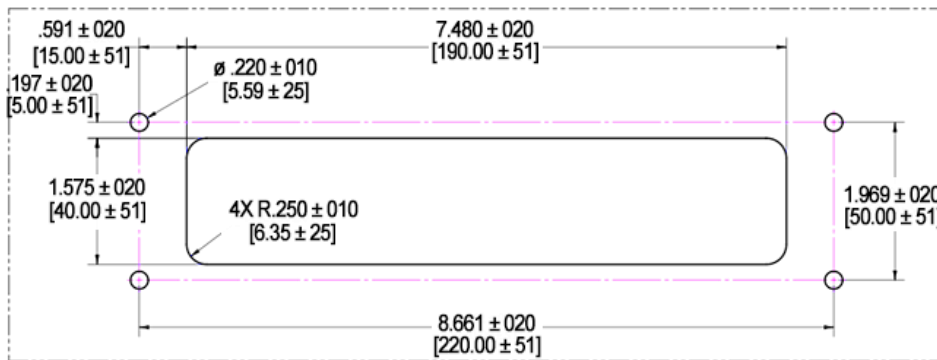

SURFACE MOUNT PANEL CUTOUT DIMENSIONS
FULL SCALE

Mounting the Unit

1. Place the back side of the display through the opening in the dash.
2. Use the four included screws from the mounting kit (78-00-1294) to attach the unit to the bracket and torque to 10 inch-pounds.

Available Accessories for the PV1200

The following PV1200 accessories are available through Enovation Controls:

Part Number	Description	Order Details
78700634	PV1200, Non-touch, Non-connected	Display
78700633	PV1200-T, Touch, Non-connected	Display
78090098	Programming Kit, PV780/PV1200	Accessories
78001294	Kit, Mounting Bracket, PV1200	
78001055	Harness, Gray Connector, USB	
78001056	Harness, Gray Connector, Flying Leads	
78001057	Harness, Black Connector, Flying Leads	
78001017	Harness, Black Connector, Development	
78001018	Harness, Gray Connector, Development	
78090069	Harness, PV750/PV1200 Conversion, Power/CAN	Service

Wiring Information

Pinout Specifications

Black Connector	
1	Digital Input 1
2	Analog Input 3
3	Analog Input 2
4	Analog Input 1
5	CAN1 Low
6	CAN1 High
7	Battery
8	Ground
9	Analog Input 3 Ground
10	Analog Input 2 Ground
11	Analog Input 1 Ground
12	Digital Input 3
13	Digital Input 2
14	Frequency Output 1
15	Ignition Input
16	No Connect
17	No Connect
18	CAN2 Low
19	CAN2 High
20	Digital Input 4
21	Digital Input 5
22	Digital Output
23	Frequency Output 2

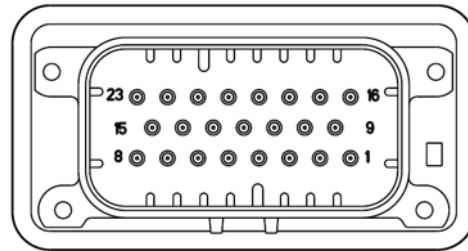

AMP 770680-1

Gray Connector	
1	Video Input 1
2	Video Input 2
3	Video Input 3
4	RS-485 High
5	RS-485 Low
6	No Connect
7	No Connect
8	No Connect
9	Video Input 1 Ground
10	Video Input 2 Ground
11	Video Input 3 Ground
12	No Connect
13	Frequency Input
14	Frequency Return
15	No Connect
16	USB D-
17	USB D+
18	USB 5V
19	USB Ground
20	USB Shield
21	No Connect
22	No Connect
23	No Connect

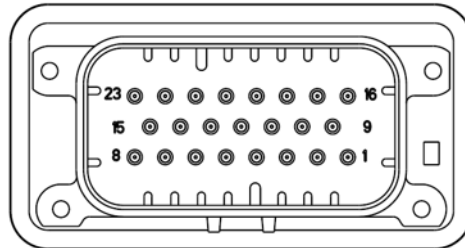

AMP 770680-4

Ethernet (M12) Connector	
1	Ethernet TX+
2	Ethernet RX+
3	Ethernet TX-
4	Ethernet RX-
5	Ethernet Ground

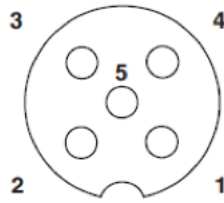

M-12, 5-pos, A-coded,
Plastic Knurl Connector Only

NOTE: Ethernet connectivity is optional.

Configuration Information

Follow these steps to download a custom configuration to the PV1200 display:

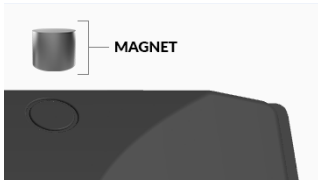
Step	Action
1	Turn off the display.
2	<p>Insert the USB drive that contains the new configuration file into the display's attached USB pigtail.</p> <p>NOTE: The model number 78700634 is Non-Touch only. To update the display an automatic updater is built into the bootloader. For the PV1200 Non-Touch unit only, rename the configuration file to 78700634-autoupload.pv1. Place only the 78700634-autoupload.pv1 onto the USB drive. When the unit is in bootloader mode, the file will be recognized and the display will be automatically updated.</p>
3	<p>Place a magnet onto the spot shown here on the upper right side of the back of the display:</p> 
4	Power the display back on, continually holding the magnet in place.
5	Remove the magnet when the display shows the utility for loading new software.
6	Touch the arrow keys on the screen to select the configuration file from the USB to be loaded into the display. The PV1200 Non-Touch unit will automatically boot into its auto-update file.

Step	Action
7	Start the configuration load by pressing the right arrow/green arrow key on the screen twice.
8	Once completed, the unit will reboot into the loaded application.

Wiring Schematics – Black Connector



WARNING: Failure to install the unit per the specified wiring diagrams may cause damage to the unit. **DO NOT** connect power to the video ground. Warranty is void for damage caused by incorrect wiring.

J1 (BLACK CONNECTOR)

Analog Inputs

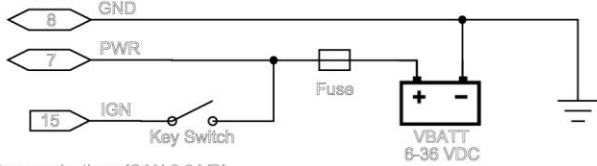

NOTES:

- Mating connector AMPSEAL 770680-1 plug with 770854-3 sockets
- Use 20 to 16 AWG (0.5 to 1.4 mm²)
- Wire diameter of 1.7 to 2.7 mm.
- Install seal plug 770678-1 in perforated connector wire cavities
- An ISO8820 certified automotive fuse rated for no more than 5A shall be used to power the unit.

Communications (CAN 2.0A/B)

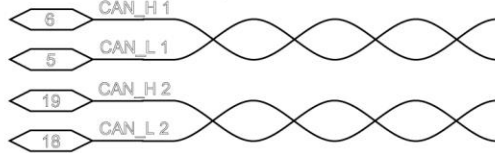

Wire per J1939-11 (STP) or J1939-15 (UTP)

- J1939-11: Keep stub <1m length; up to 30 nodes; 40m max length
- J1939-15: Keep stub <3m length; up to 10 nodes; 40m max length
- Locate display node >0.1m from nearest node
- Space nodes unequally
- Keep CANbus trunk as linear as possible
- Type I - Use external 120 ohm terminator
- Type II - Enable internal terminator

Analog Inputs

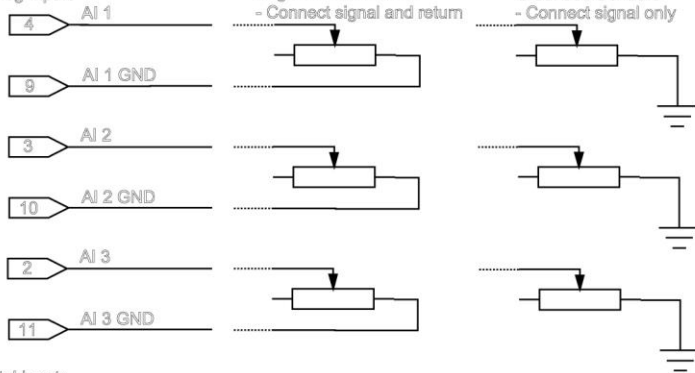

0-5 VDC Sensors

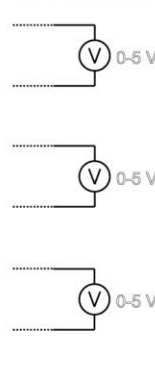

4-20 mA Sensors

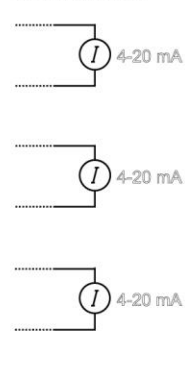

Digital Inputs

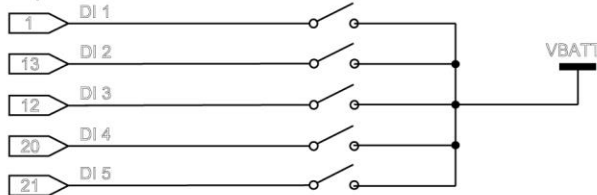

Digital Output

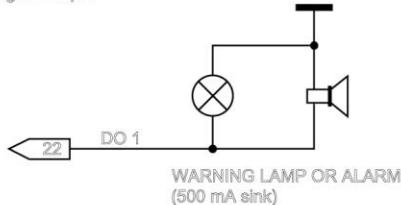

Frequency Output



Wiring Schematics – Gray Connector



WARNING: Failure to install the unit per the specified wiring diagrams may cause damage to the unit. **DO NOT** connect power to the video ground. Warranty is void for damage caused by incorrect wiring.

J2 (GRAY CONNECTOR)

- NOTES:
- Mating connector AMPSEAL 770880-4 plug with 770854-3 sockets
 - Use 20 to 16 AWG (0.5 to 1.4 mm²)
 - Wire diameter of 1.7 to 2.7 mm.
 - Install seal plug 770878-1 in perforated connector wire cavities

USB (Programming and Data Logging)

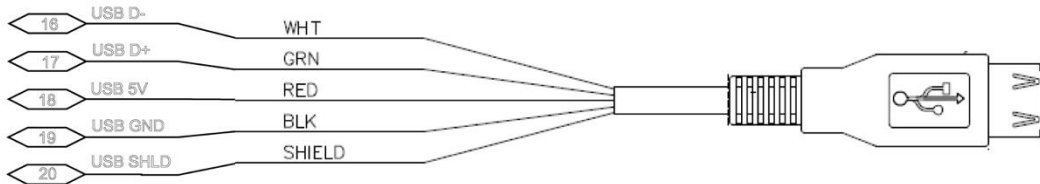

Video Inputs



- VIDEO CAMERA NOTES
- NTSC or PAL format
 - Do not mix camera types
 - Follow camera manufacturer specifications for power
 - Do not power camera using VIDEO GND

Frequency Input (Engine or Shaft Speed from mag pick-up)

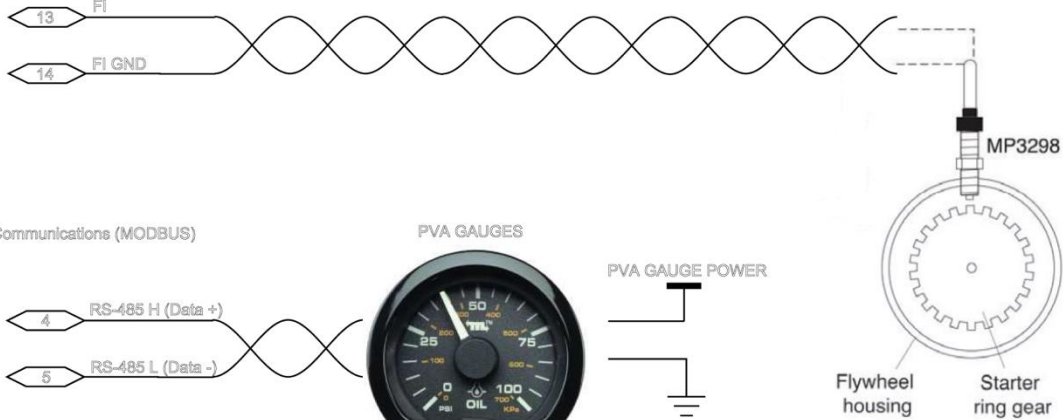

Communications (MODBUS)



Specifications

Computing	
Main Processor:	Renesas® R-Car M2 with Arm® Cortex-A15 dual core processor @ 1.5 GHz (32-bit)
Operating System:	QNX® Real-time Operating System
Storage:	8 GB Flash memory
Ram:	512 MB DDR3-SDRAM
Graphics:	Renesas graphics processor
Display	
Type:	12.3" [320 mm (H) X 130 mm (W)] viewable area, LVDS IPS LCD with LED backlight, 24-bit color
Resolution:	1280 x 480 pixels
Contrast Ratio:	800:1 (typical)
Brightness:	1000 cd/m ²
Surface:	Anti-glare
Touch Panel:	Projected capacitive (PCAP) with glove touch
Hardware	
Real-time Clock:	Available with battery backup
Connectors:	(2) Ampseal 23 pin (Main) (1) M12, 5-pin [Ethernet (Optional)] (1) USB pigtail
Video Inputs:	(3) NTSC/PAL
Communication	
CAN:	(2) CAN 2.0B according to ISO 11898-2, J1939 and proprietary messaging
Serial:	(1) RS-485 serial (Modbus: Master/Slave)
USB:	(2) USB 2.0 full speed host
Ethernet:	(1) Ethernet 10/100 Base-T (optional)
Wi-Fi:	802.11 b/g radio (optional)
Bluetooth:	Fully integrated Bluetooth 2.1, Class 1 (optional)

Electrical	
Operating Volts:	6-36 VDC, reverse polarity protected
Outputs:	(1) 500 mA switched low-side (1) Frequency output (2Hz – 3KHz)
Inputs:	(3) Analog 0-5 VDC, 4-20mA, resistive, 10-bit resolution (5) Discrete digital, active high (1) Frequency in (2Hz – 10KHz) 5V pk-pk min, 49V pk-pk max
Environmental	
Operating Temperature:	-40°C to +70°C (-40°F to +158°F)
Storage Temperature:	-40°C to +85°C (-40°F to +185°F)
Protection:	IP66 and IP67, front and back, for outdoor use
Vibration:	3.9 Grms (10 – 350Hz), 3 axes (ISO15003)
Shock:	±50G in 3 axes
EMC/EMI:	SAE J1113, ISO 13766, CE per 2014/30/EU

Dimensions

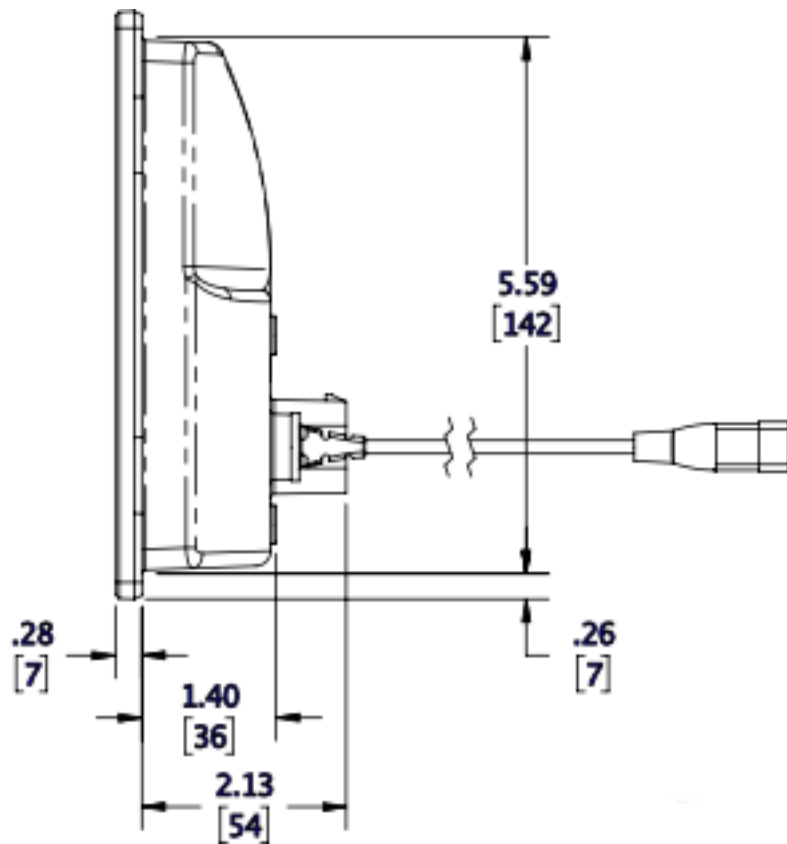
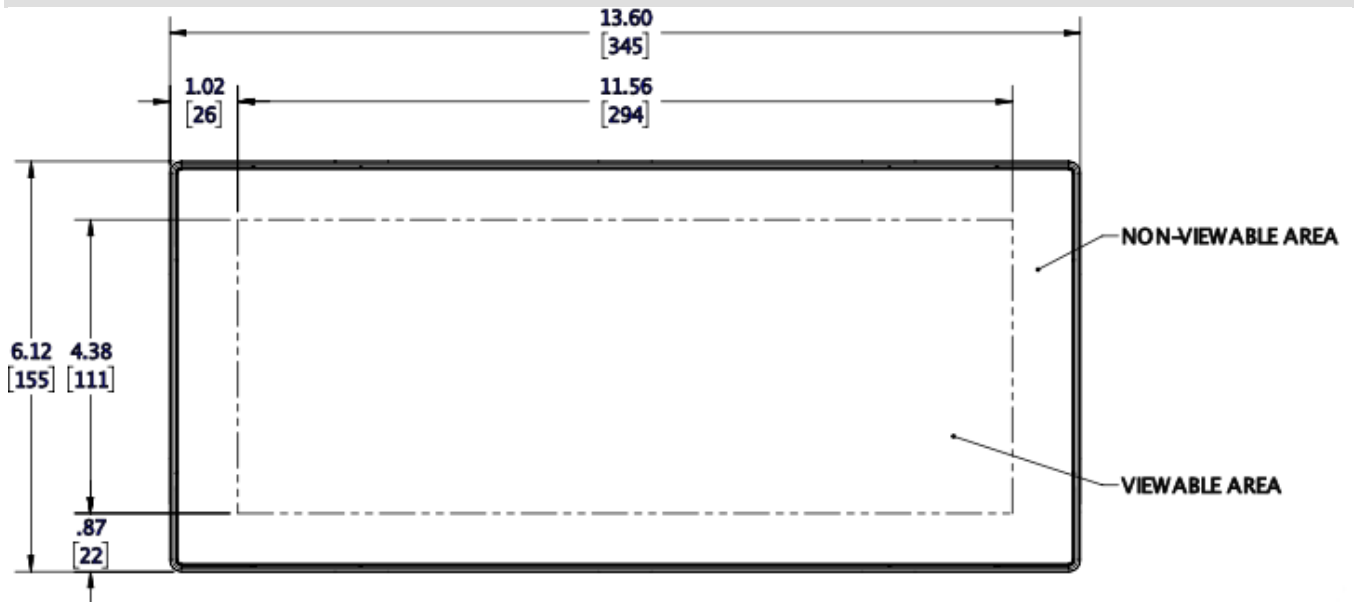

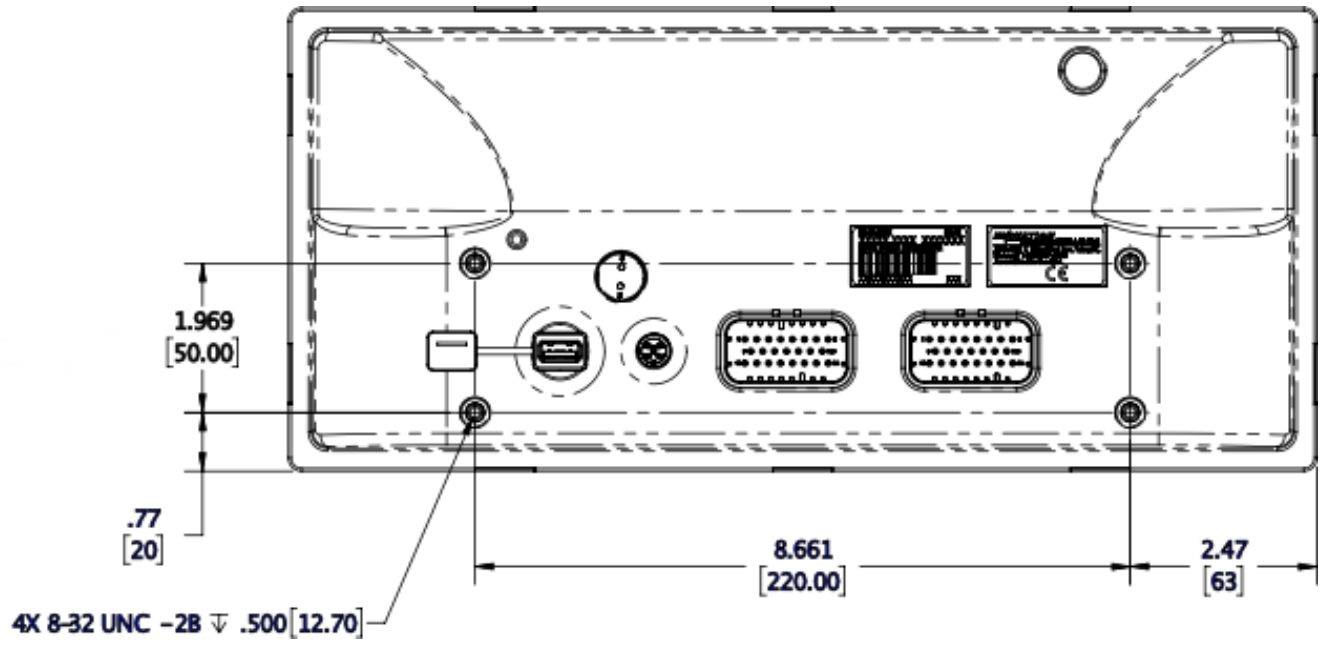

In order to consistently bring you the highest quality, full-featured products, we reserve the right to change our specifications and designs at any time. MURPHY products and the Murphy logo are registered and/or common law trademarks of Enovation Controls, LLC. This document, including textual matter and illustrations, is copyright protected by Enovation Controls, LLC, with all rights reserved. (c) 2019 Enovation Controls, LLC. A copy of the warranty may be viewed or printed by going to www.enovationcontrols.com/warranty

ENOVIATION CONTROLS CORPORATE HEADQUARTERS

5311 S 122ND EAST AVENUE
TULSA, OK 74146

ENOVIATION CONTROLS LTD. – UNITED KINGDOM

CHURCH ROAD LAVERSTOCK
SALISBURY SP1 1QZ UK

SUN MURPHY INTERNATIONAL TRADING (SHANGHAI) CO., LTD

B15 ROOM, 6# BUILDING, 351 SIZHUAN ROAD
SONGJIANG DISTRICT, SHANGHAI 201601, CHINA

ENOVIATION CONTROLS INDIA PVT. LTD.

301, 3RD FLOOR, KRISNA CHAMBERS,
11 GALAXY GARDENS, NORTH MAIN ROAD,
KOREGAON PARK, PUNE 411001,
MAHARASHTRA, INDIA

U.S. SALES & SUPPORT

PHONE: 918 317 4100
EMAIL: SALES@ENOVIATIONCONTROLS.COM
WWW.ENOVIATIONCONTROLS.COM

MURPHY INDUSTRIAL PANEL DIVISION

PHONE: 918 317 4100
EMAIL: IPDSALES@ENOVIATIONCONTROLS.COM

INTERNATIONAL SALES & SUPPORT

EUROPE, MIDDLE EAST, AFRICA

PHONE: +44 1722 410055
EMAIL: SALES@ENOVIATIONCONTROLS.EU

CHINA

PHONE: +86 21 6237 5885
EMAIL: APSALES@ENOVIATIONCONTROLS.COM

INDIA

PHONE: +91 91581 37633
EMAIL: INDIASALES@ENOVIATIONCONTROLS.COM



FM 28221 (Tulsa, OK - USA)
FM 29422 (UK)