

Installation of Digital Tach/Hourmeter with Overspeed Trip Point

Models: SHD30 and SHD30-45

Please read the following information before installing. A visual inspection for any damage which may have occurred during shipping is recommended. It is your responsibility to have a qualified person install the unit, and make sure it conforms with NEC and local codes.

WARNING

BEFORE BEGINNING INSTALLATION OF THIS PRODUCT

- ✓ Disconnect all electrical power to the machine
- ✓ Make sure the machine cannot operate during installation
- ✓ Follow all safety warnings of the machine manufacturer
- ✓ Read and follow all installation instructions

Description

The SHD30 and SHD30-45 models are microprocessor-based digital tachometers with hourmeter and overspeed trip point. The overspeed trip point can be connected as either a form C relay output or as a normally open SCR output.

In Class I, Div. 2, hazardous locations the SHD30 form “C” relay contact is restricted for use with FW Murphy non-incendive or intrinsically-safe instruments. In non-hazardous locations the relay contact may be used to switch resistive loads not exceeding 0.5 A @ 30 VDC or 125 VAC.

When connected as a normally open SCR, the output is rated 0.5 A, 350 VDC continuous and can switch up to 3 A @ 350 VDC momentary. The SCR output may be used to switch designated normally open sensor inputs.

Specifications

Power input:

- CD ignition: 90 to 350 VDC, 150 μ A typical @ 90 VDC; 300 μ A @ 350 VDC.
- Magnetic Pickup: 5 to 120 Vrms.
- 325 μ A typical @ 5 Vrms, 100 Hz; 450 μ A typical @ 5 Vrms, 1 kHz;
- 1 mA typical @ 5 Vrms, 5 kHz; 2 mA typical @ 5 Vrms, 10 kHz;
- 15 mW max. @ 5 Vrms, 10 kHz; 2.8 W max. @ 120 Vrms, 10 kHz.

Backup Battery: 2 replaceable, long life Lithium batteries, Panasonic CR2032 or equivalent, 3 V, 220 mAh power.

Operating Temperature: -4° to 158° F (-20° to 70° C).

Storage Temperature: -40° to 300° F (-40° to 150° C).

Ignition Frequency Range: 3 to 666 Hz.

Magnetic Pickup Frequency Range: 1 to 10 kHz.

Overspeed Output:

- Connected to S.C.R. (Silicon Controlled Rectifier) terminals:
0.5 A, 350 VDC continuous.
- Connected to Form C Relay terminals:
Relay Contact, 0.5 A, 30 VDC, 125 VAC resistive.

Tachometer Accuracy: $\pm 0.5\%$ of the display reading or ± 1 RPM whichever is greater.

Hourmeter Range: 0 to 65535 hrs.

Hourmeter Accuracy: ± 15 minutes per year.

Approvals: CSA approved for Cl. I, Div. 2, Grps. C & D hazardous areas.

Mounting

The SHD30 is designed for installation in panels from 0.032 to 0.125 in. (1 to 3 mm) thick. A round hole, 3-1/8 in. (79 mm) in diameter is needed for mounting. Install the unit within a weatherproof enclosure to protect it from the elements. Keep the unit away from ignition coils and coil leads; a minimum of 12 in. (305 mm) is recommended.



Approved for Class I, Division 2, Groups C & D Hazardous Areas when installed per Drawing 20-08-0258



SHD30 Dimensions

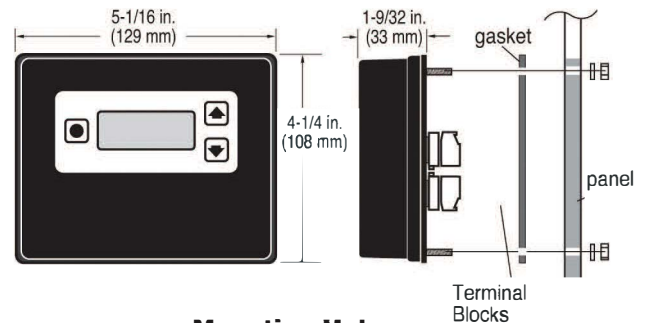

Mounting Hole

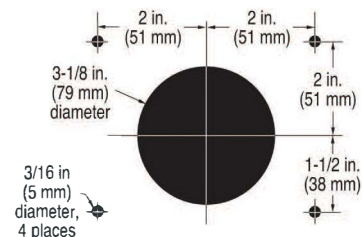

SHD30-45 Dimensions/Mounting

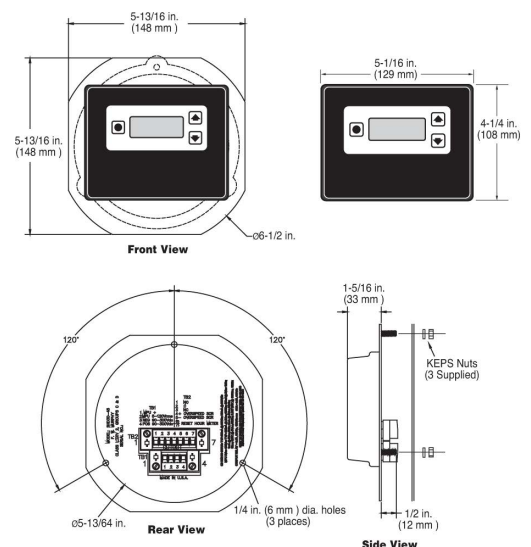

TYPICAL WIRING



WARNING: PERFORM THE WIRING INSTALLATION WITH THE POWER SOURCE OFF. NEVER ROUTE THE SHD30 MODELS OVERSPEED OUTPUT LEADS WITH PRIMARY IGNITION WIRING.

Connecting the Magnetic Pickup

Connect the magnetic pickup cable conductors to the 4-conductor terminal strip as shown in **Figure 2**. Use a two conductor shielded cable between the SHD30 models and the magnetic pickup.

Figure 2: SHD30 models to magnetic pickup typical wiring

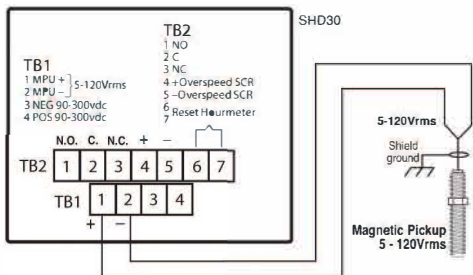

Table 1: Output Voltage & Polarity of Common CD Ignitions

Ignition MFG & Series	Ground Polarity	Peak Output Voltage	Use Figure
Altronic I & V	Negative	120	3
Altronic III	Negative	225	3
Altronic II	Positive	350	4
Bendix S-1800, BLAR	Negative	250	3
Bendix Side-winder	Positive	300	4
Fairbanks Morse SCSA	Positive	180	4
Fairbanks Morse 3000 & 9000	Negative	225	3
American Bosch Magtronic	Negative	165	3

Connecting to CD Ignition

Before wiring the SHD30 models, determine the output voltage and ground polarity of the ignition. **Table 1** (below, left) lists the Peak Output Voltage and Ground Polarity of some common ignitions.

Connect the SHD30 models to a positive or a negative ground CD ignition as shown in **Figures 3 or 4**.

Figure 3: SHD30 models typical wiring for NEGATIVE ground ignition

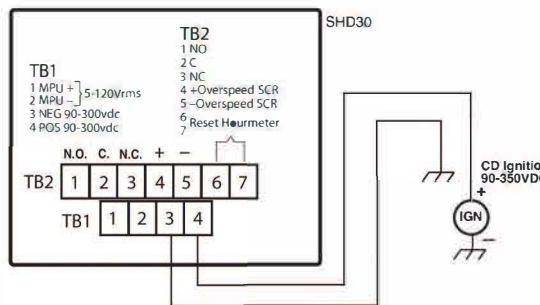
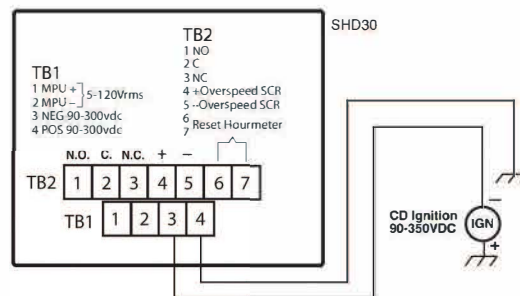

Figure 4: SHD30 models typical wiring for POSITIVE ground ignition



OVERSPEED OUTPUT WIRING

Connecting the Overspeed Output

A 7-conductor terminal strip, on the back of the SHD30 models, is provided for connection of the overspeed output. Terminals C., and N.C. are used for connecting the output as a normally closed relay contact. Terminals (+) and (-) are used for connecting the output as a normally open SCR. Shown in **Figure 5** is a typical wiring installation of the SHD30 models normally closed relay output connected to a FW Murphy MARK III digital annunciator. **Figure 6** shows a typical

Figure 5: SHD30 models Normally Closed Relay output to MARK III

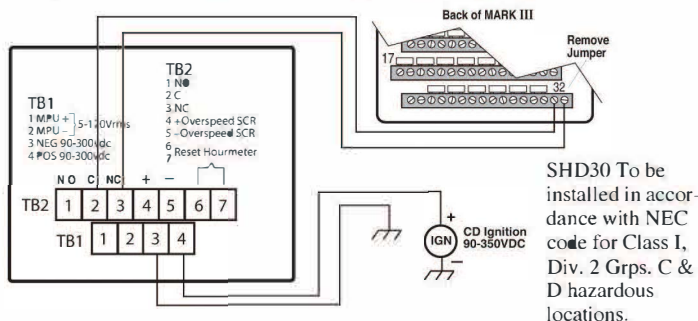

SHD30 To be installed in accordance with NEC code for Class I, Div. 2 Grps. C & D hazardous locations.

wiring of the SHD30 models normally open SCR output connected to a FW Murphy MARK III digital fault annunciator. **Figure 7** displays a typical wiring of the SHD30 models normally open SCR output to a FW Murphy MARK IV annunciator. **Figure 8** displays a typical wiring of the SHD30 models normally closed relay output to a FW Murphy LCDT-NC annunciator. **Figure 9** displays a typical wiring of the SHD30 models normally open SCR output to a FW Murphy LCDT-NO annunciator.

Figure 6: SHD30 models Normally Open SCR output to MARK III

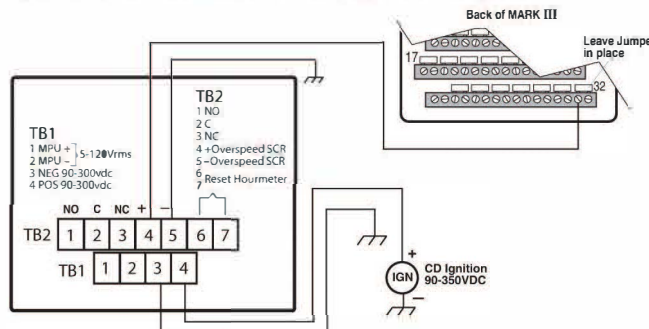

SHD30 models To be installed in accordance with NEC code for Class I, Div. 2 Grps. C & D hazardous locations.



WARNING: Overspeed relay contact for use with FW Murphy non-incendive or intrinsically safe products only.

OVERSPEED OUTPUT WIRING *continued*



WARNING: PERFORM THE WIRING INSTALLATION WITH THE POWER SOURCE OFF.
NEVER ROUTE THE SHD30 MODELS OVERSPEED OUTPUT LEADS WITH PRIMARY IGNITION WIRING.

Figure 8: SHD30 models Normally Closed Relay output to LCDT-NC

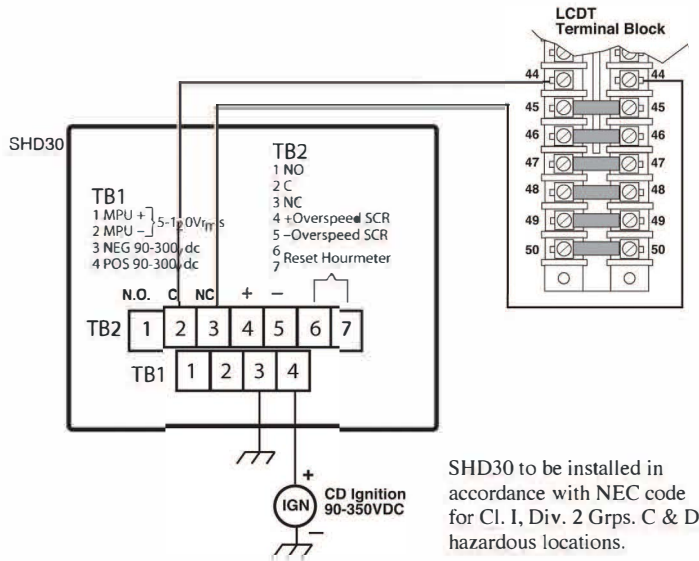

WARNING: Overspeed relay contact for use with FW Murphy non-incendive or intrinsically safe products only.

Figure 7: SHD30 models Normally Open SCR output to MARK IV

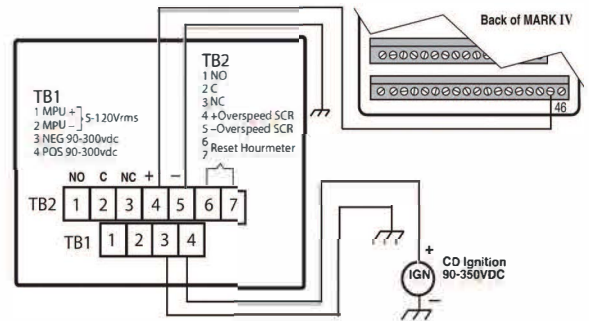

SHD30 models to be installed in accordance with NEC code for Cl. I, Div. 2 Grps. C & D hazardous locations.

Figure 9: SHD30 models Normally Open S.C.R. output to LCDT-NO

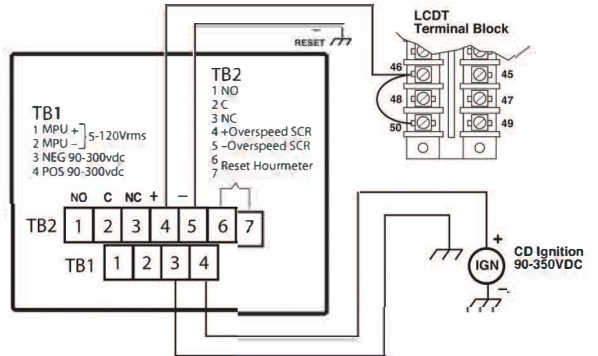

SHD30 models to be installed in accordance with NEC code for Cl. I, Div. 2 Grps. C & D hazardous locations.

TYPICAL WIRING FOR CONTROL PANEL

Shown below is the SHD30 models with SCR output connected to TATTLETALE[®] magnetic switches and SWICHGAGE[®] instruments using an

Figure 10: SHD30 models with Normally Open S.C.R. output typical wiring for negative ground ignition systems.

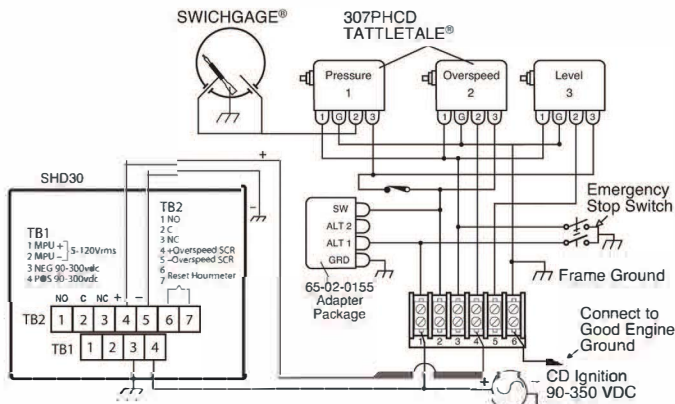

SHD30 models to be installed in accordance with NEC code for Class I, Div. 2 Grps. C & D hazardous locations.

Tattle tale and Swichgag are trademarks of Enovation Controls LLC.

adapter package. **Figure 10** shows a typical wiring for negative ground ignition. **Figure 11** shows a typical wiring for positive ground ignition.

Figure 11: SHD30 models with Normally Open S.C.R. output typical wiring for positive ground ignition systems.

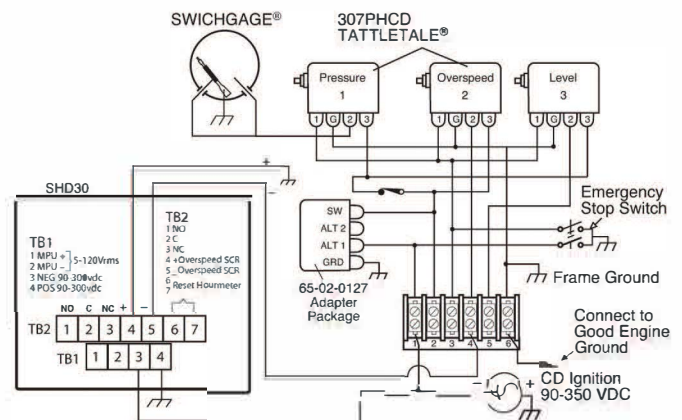

SHD30 models to be installed in accordance with NEC code for Class I, Div. 2 Grps. C & D hazardous locations.

CALIBRATING AND OPERATING THE SHD30

Resetting the Run Hours

To reset the Run hours to zero, place a jumper between terminals #6 and #7 (7-point terminal block). Press and hold the Reset Relay Read Hours key on the SHD30 models faceplate for 5 seconds. The Run Hours will be reset to zero.

Presetting the Run Hours

To preset the run hours first you must reset the run hours (see the above paragraph). After resetting the hours continue to hold the Reset Relay Read Hours key for another 5 seconds. The run hours will flash 3 times. At this point the hours can be preset in hours using the up/down keys to increase or decrease the hours. When the desired preset run hours is reached, continue holding the Reset Relay Read Hours key for another 5 seconds. The run hours will flash 3 times indicating the run hours value has been saved.

Pulses Per Revolution Adjustments

The SHD30 models measures RPM based on the number of pulses per engine revolution. Pulses can come from either an ignition or a magnetic pickup. For an ignition, the number of pulses per revolution is determined by the number of cylinders and cycles, refer to **Table 2**.

For magnetic pickup, the number of pulses per revolution is simply the number of teeth on the gear. To adjust the pulses per revolution do the following:

1. Press and hold the Reset Relay Read Hours key. Run hours will be displayed. Continue to hold the Reset Relay Read Hours key.
2. Press the DOWN key and hold for 5 seconds. The current pulses per revolution value will flash indicating that it now can be changed.
3. Continue to hold the Reset Relay Read Hours key. Use the UP/DOWN keys to increase and decrease the number of pulses per revolution. Once the desired value is displayed, continue holding Reset Relay key for 5 seconds, the display will flash 3 times indicating that the new value is saved (the display MUST flash 3 times for the new value to be saved).

Table 2: Cylinders, Cycles, Pulses Per Revolution

NOTE: Divide the number of cylinders by 2 for split capacitor ignitions. Multiply the number of cylinders by 2 for throw away spark ignitions.

Cylinders	Cycles	Pulses	Cylinders	Cycles	Pulses
1	2	1	6	2	6
2	2	2	6	4	3
2	4	1	8	2	8
3	2	3	8	4	4
4	2	4	10	4	5
4	4	2	12	4	6
5	2	5	16	4	8

Overspeed Set Point Adjustments

To adjust the overspeed set point perform the following steps:

1. Press and hold the Reset Relay Read Hours key. Run hours will be displayed. Continue to hold the Reset Relay Read Hours key.
2. Press the UP key and hold for 5 seconds. The current overspeed set point value will flash indicating that it now can be changed.
3. Continue to hold the Reset Relay Read Hours key. Use the UP/DOWN keys to increase and decrease the value of overspeed set point. Once the desired value is displayed, continue holding the Reset Relay Read Hours key for 5 seconds, the display will flash 3 times indicating that the new value is saved (the display MUST flash 3 times for the new value to be saved).

Operation Sequence

When the SHD30 models receive a tach signal, it begins displaying RPM. When the RPM reading is flashing, it means that the overspeed setting has been tripped (see *Overspeed Output Tripped*, below).

Run Hours Display

To display the run hours, press Reset Relay Read Hours key. The run hours will be displayed for 5 seconds before returning to RPM.

To configure the SHD30 models to automatically toggle between displaying rpm and run hours, press the Reset Relay Read Hours key twice quickly. The display will toggle between displaying rpm for 6 seconds, and run hours for 2 seconds. The setting is saved and the display will toggle every time the unit is powered up. Press the Reset Relay Read Hours key twice again to return to the rpm display.

Overspeed Set Point Display

To display the overspeed set point, press the UP key. The current overspeed set point will be displayed for 5 seconds before returning to RPM.

Overspeed Output Tripped

When RPM exceeds the overspeed setting, the normally open SCR output trips and latches, and the normally closed relay output opens. To reset the relay output, press the Reset Relay Read Hours key after the RPM has fallen below overspeed set point. The current through the SCR must be broken to allow the SCR to reset in addition to pressing the Reset Relay Read Hours key.

Pulses Per Revolution Display

To display the pulses per revolution, press the DOWN key. Current pulses per revolution will be displayed for 5 seconds before returning to RPM.

Replacing the Backup Batteries

Backup batteries are provided to allow display of the run hours and for resetting the overspeed relay after power is lost. To replace the batteries, first disconnect the terminal block plugs and remove the SHD30 models from the panel. Remove the 3 small screws located on the back of the SHD30 models and VERY CAREFULLY remove the circuit board. Replace the existing batteries with new ones (see specifications). Replace the circuit board and the screws. Remount the SHD30 models on the panel.

In order to consistently bring you the highest quality, full-featured products, we reserve the right to change our specifications and designs at any time. FW MURPHY product names and the FW MURPHY logo are proprietary trademarks. This document, including textual matter and illustrations, is copyright protected with all rights reserved. (c) 2019 FW MURPHY. A copy of our typical warranty may be viewed or printed by going to www.fwmurphy.com/warranty.

FW MURPHY PRODUCTION CONTROLS

SALES, SERVICES & ACCOUNTING
4646 S. HARVARD AVE.
TULSA, OK 74135

CONTROL SYSTEMS & SERVICES
105 RANDON DYER ROAD
ROSENBERG, TX 77471

MANUFACTURING
5757 FARINON DRIVE
SAN ANTONIO, TX 78249

DOMESTIC SALES & SUPPORT

FW MURPHY PRODUCTS
PHONE: 918 957 1000
EMAIL: INFO@FWMURPHY.COM
WWW.FWMURPHY.COM

FW MURPHY CONTROL SYSTEMS & SERVICES
PHONE: 281 633 4500
EMAIL: CSS-SOLUTIONS@FWMURPHY.COM

INTERNATIONAL SALES & SUPPORT

CHINA
PHONE: +86 571 8788 6060
EMAIL: INTERNATIONAL@FWMURPHY.COM

LATIN AMERICA & CARIBBEAN
PHONE: +1 918 770 8775
EMAIL: INTERNATIONAL@FWMURPHY.COM

SOUTH KOREA
PHONE: +82 70 7951 4100
EMAIL: INTERNATIONAL@FWMURPHY.COM



FM 668576 (San Antonio, TX - USA)
FM 668933 (Rosenberg, TX - USA)



FM 523851 (China) TS 589322 (China)