

# AC Current Overload Relay

## OLR600



- **AC over current protection**
- **Adjustable full load setting, with proportional current / time response**
- **Adjustable 'Instant trip' setting**
- **DIN rail / surface mountable**

### Description

The OLR600 is a relay-based device, used for protecting mains or generator AC supplies against overload or short circuit faults. An internal digital counter/timer provides an accurate, measured response, giving an instant trip for large over-current faults and longer time delays for less severe overloads.

The unit operates with three external current transformers (not supplied). These are wired in star formation to give between 3 and 5 Amps at system full load current. (Current transformers with 5 Amp secondary coils are normally therefore used.)

The front facia 'Set Full Load' potentiometer is set (between 3 and 5 Amps) to match the CT secondary current at full AC load. With DC power applied and all three phase currents below the 'set full load' level, the OLR's relay is energised and the front facia left-hand LED is lit.

The right hand 'full load' LED lights if any phase current rises above the full load setting. If any phase current increases to above 110% of full load, the OLR starts its internal counter/timer. Sustained overloads cause the count to increase (more quickly for higher currents) and the relay will de-energise if the counter becomes full: see overleaf for a current/time response curve. If, however, the current returns below the full load level, the count will decrease (more quickly for lower currents), the relay will remain energised and the counter will eventually reset.

Additional control is provided by a front facia 'set instant trip' potentiometer, expressed in multiples of the full load current. If the measured current exceeds this level, the OLR trips instantly, regardless of the normal current/time curve.

Once the relay de-energises and the load current reduces, the counter/timing circuit ensures that the relay does not re-energise for some time: the actual time is again dependent on the level of measured load current (typically 15 seconds if the load current falls to zero).

### Product specification

<b>power supply:</b>	
operating voltage range	12 V units: 9 - 15 V DC 24 V units: 18 - 30 V DC
power consumption	< 1.5 W
<b>AC input</b>	3 phase, star connected current transformers (5 Amp secondary coil)
<b>trip adjustment:</b>	
full load adjustment	3 – 5 Amps (secondary coil current)
instant trip adjustment	1 – 3 times full load
<b>relay output:</b>	
contact type	DPDT (volt free)
current rating	5A max. @ 240 VAC (resistive)
rated operations	2 x 10 <sup>5</sup> operations
trip time	load variable (curve overleaf)
<b>general:</b>	
operating temperature	-10 to +55 °C
weight	approx. 360 g
dimensions (w x h x d)	50 x 75 x 110 mm

The OLR600 is powered using a battery/DC supply, 12V or 24V (please specify). The unit is housed in a robust polycarbonate case, designed for DIN rail or surface mounting.

### Warranty

A two year limited warranty on materials and workmanship is given with this Murphy product. Details are available on request and are packed with each unit.

## Electrical connection

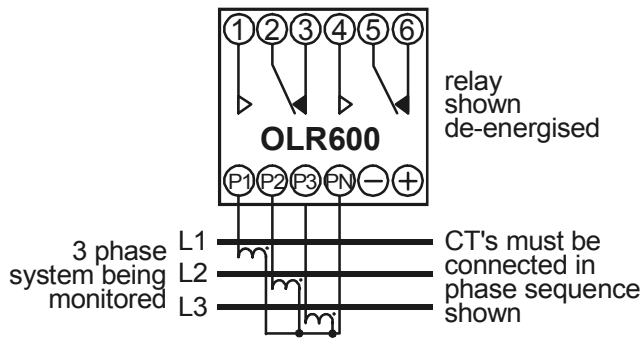

## Trip current / time response

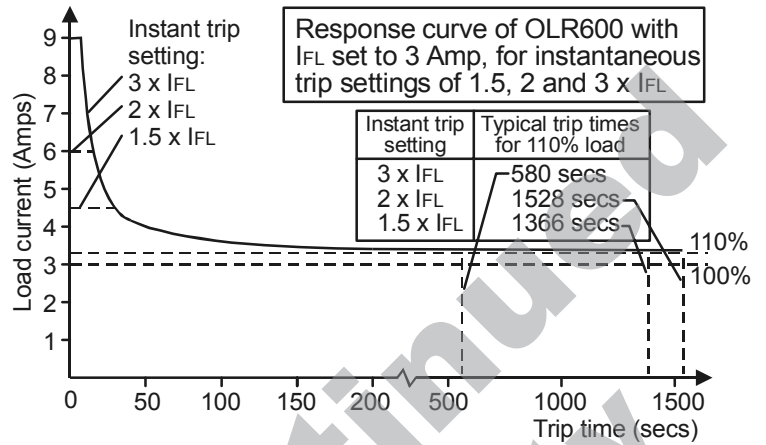

## How to order

Stock code	Model, description
76.70.0046	OLR600/A, 12 VDC supply
76.70.0032	OLR600/B, 24 VDC supply

## Dimensions

(mm)

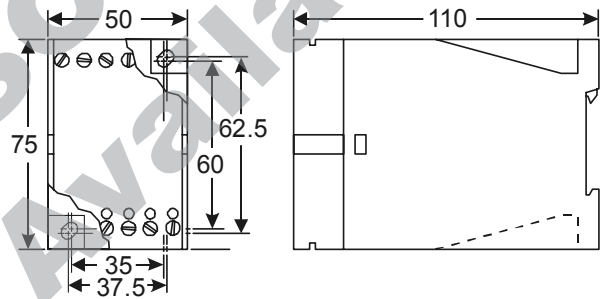

### FWMurphy

PO Box 470248  
Tulsa, Oklahoma 74147, USA  
tel: +1 918 317 4100  
fax: +1 918 317 4266  
email: sales@fwmurphy.com  
web: www.fwmurphy.com

**CONTROL SYSTEMS AND SERVICES DIVISION**  
PO Box 1819, Rosenberg, Texas 77471, USA  
tel: +1 281 342 0297  
fax: +1 281 341 6006  
email: sales@fwmurphy.com

**MURPHY DE MEXICO S.A. DE C.V.**  
Blvd. Antonio Rocha Cordero 300, Fracción del Aguaje  
San Luis Potosí, S.L.P. México 78384  
tel: +52 444 8206264  
fax: +52 444 8206336  
Villahermosa office tel: +52 993 3162117  
email: ventasmex@murphymex.com.mx  
web: www.murphymex.com.mx

**FRANK W. MURPHY LTD.**  
Church Rd, Laverstock, Salisbury, SP1 1QZ, UK  
tel: +44 1722 410055  
fax: +44 1722 410088  
email: sales@fwmurphy.co.uk  
web: www.fwmurphy.co.uk

**MURPHY SWITCH OF CALIFORNIA**  
41343 12th Street West,  
Palmdale, CA 93551-1442, USA  
tel: +1 661 272 4700  
fax: +1 661 947 7570  
email: sales@murphyswitch.com  
web: www.murphyswitch.com

**MACQUARRIE CORPORATION**  
1620 Hume Highway,  
Campbellfield, Victoria 3061, Australia  
tel: +61 3 9358 5555  
fax: +61 3 9358 5558  
email: murphy@macquarrie.com.au



USA - ISO9001:2000 FM 28221  
UK - ISO9001:2000 FM 29422

In order to consistently bring you the highest quality, full featured products, we reserve the right to change our specifications and designs at any time.