

# 3ST

## Three Point Speed Trip Relays

### Installation Instructions

Please read the following information before installing. A visual inspection of this product for damage during shipping is recommended before installation. It is your responsibility to ensure that qualified mechanical and electrical technicians install this product. If in doubt, please contact your local Murphy or Enovation Controls representative.

### General Information

# WARNING

**BEFORE BEGINNING INSTALLATION OF THIS PRODUCT**

- ✓ Disconnect all electrical power to the machine
- ✓ Make sure the machine cannot operate during installation
- ✓ Follow all safety warnings of the machine manufacturer
- ✓ Read and follow all installation instructions

The 3ST provides three independent speed relays in one compact unit. The module can be used in the control and protection of engines, generators, pumps, or any moving machinery that requires the monitoring of engine speed and controlled tripping.

This document provides installation and calibration details for standard 3ST/1 and 3ST/2 models. Additional information about the 3ST may be found in the following documents:

Doc. ref.	Title
ms5885	3ST sales bulletin

The above information is available on request from your Enovation Controls or Murphy representative, or from the 'products' section of our support website <http://support.enovationcontrols.com>

For further details of non-standard units (with model references other than 3ST/1 or 3ST/2), please contact your local Enovation Controls or Murphy representative.



### Specifications

#### Power supply

##### Operating voltage, steady state:

3ST/1 (24V DC): 16 to 32 V DC  
3ST/2 (12V DC): 8 – 16 V DC

**Power consumption:** 4W (typ.)

#### Input

**Voltage range:** 0.5 – 80 V AC rms

**Nominal ( $f_0$ ) frequency range:** 1 – 8 kHz

#### Trip relay settings

**S1 (Crank) range:** 10 – 45% of  $f_0$

**S2 (Underspeed) range:** 50 – 95% of  $f_0$

**S3 (Overspeed) range:** 100 – 130% of  $f_0$

#### Outputs

**Relays:** SPNC (S1) and SPDT (S2 & S3) volt-free/dry contacts, rated 5A max. @ 24V DC (resistive load),  $2 \times 10^5$  operations

**Tacho/calibration:** 0 – 1mA into a 75 Ohm moving coil meter.

Output at normal engine speed = 0.75mA

#### Physical

**Operating temperature:** –10 to +55 °C / 14 to +131 °F

**Dimensions (W x D x H):** 50 x 75 x 110 mm / 1.97 x 2.95 x 4.33 in.

**Weight:** approx. 190g / 0.42 lb.

## General Information (cont.)

### Operation

The 3ST is designed to work with an engine speed transducer, typically a magnetic pickup or tacho generator. The 3ST measures the transducer signal frequency (which is proportional to engine speed) and compares this with the three pre-set trip levels. The three non-latching relays then activate or deactivate as appropriate.

On standard units, the trip relay functions are:

- S1 (Crank) Controls the automatic release of an engine starter motor.
- S2 (Underspeed) Controls protection or load switching equipment as the engine approaches or falls away from normal speed.
- S3 (Overspeed) Controls a warning circuit or shutdown of the plant on engine overspeed or open-circuit speed sensor.

Each relay has an associated front face red LED that lights when the relay is energised. For correctly calibrated standard units, all three relays are energised and all LEDs are lit when the engine is running at normal speed. The engine status can therefore be read from the front facia indicators:

S1	○	○	☀	☀	☀	CRANK	
S2	○	○	○	☀	☀	UNDERSPEED	
S3	○	☀	☀	☀	○	OVERSPEED	
	power off		power on - engine stationary/cranking		engine running but below underspeed settings	normal running	overspeed or open circuit input

Speed calibration is set using four front face, multi-turn potentiometers – see 'calibration' overleaf. The 3ST also features a 'meter' output, which may be used to assist calibration or, with a suitably scaled meter, to give indication of engine speed.

### Unpacking and familiarisation

For each 3ST ordered, the following is supplied:

- 1 x 3ST module
- (for stock units) 1 x loose, blank calibration label & 1 x clear adhesive cover

The 3ST is housed in a robust polycarbonate case, designed for DIN rail or surface mounting. The model reference and electrical connection details are labelled on the lower side of each unit (as shown right). Standard models are:

- 3ST/1 Standard unit, 24VDC power supply
- 3ST/2 Standard unit, 12VDC power supply

Each 3ST may be supplied from stock with standard calibration i.e. requiring customer set-up, or may be supplied factory calibrated to customer specifications.

On factory-calibrated units, the calibration frequencies are written on the upper side label. On stock units (order reference 3ST/1SET4 or 3ST/2SET4), this calibration label is supplied blank and loose with a clear plastic cover, to be completed and affixed after customer set-up.

### Front View

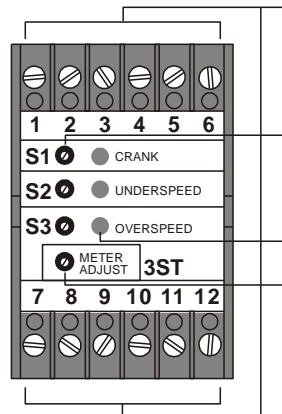

12 x screw terminals

S1, S2 and S3 speed trip settings (20 turn potentiometers)

3 x relay indicating LEDs (red)

'Meter Adjust' nominal speed calibration (20 turn potentiometer)

### Lower Side View

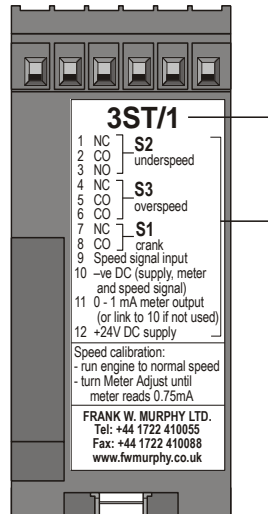

Model reference

Electrical connection details

### Upper Side View

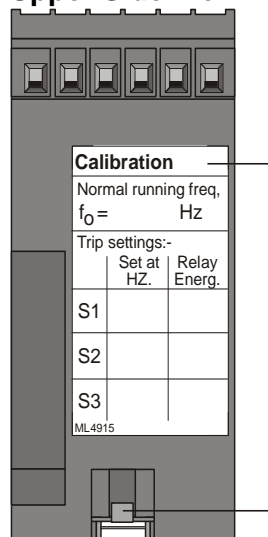

Calibration label

DIN rail clip

## Mounting

The 3ST may be mounted either directly on to a standard DIN rail, or to a flat surface via two fixing holes at the rear. Care should be taken to install the unit in a position free from ingress of water, dust or excessive moisture and temperature.

### DIN rail mounting

The rear of the case has a recessed slot and clip. Locate the slot lower groove under the lower edge of the DIN rail (A), then tilt the front of the case upwards/backwards (B) until the securing clip clicks on to the DIN rail top edge.

To remove, support the 3ST from underneath, then insert a flat head screwdriver along the top side of the case and into the securing clip (C). Use the screwdriver (D) to lever the clip upwards (E) until the case releases forward off the DIN rail (F).

### Surface mounting

Two holes at the rear of the case (dimensions right) allow the 3ST to be surface mounted. Use M5 nuts and bolts or equivalent screws.

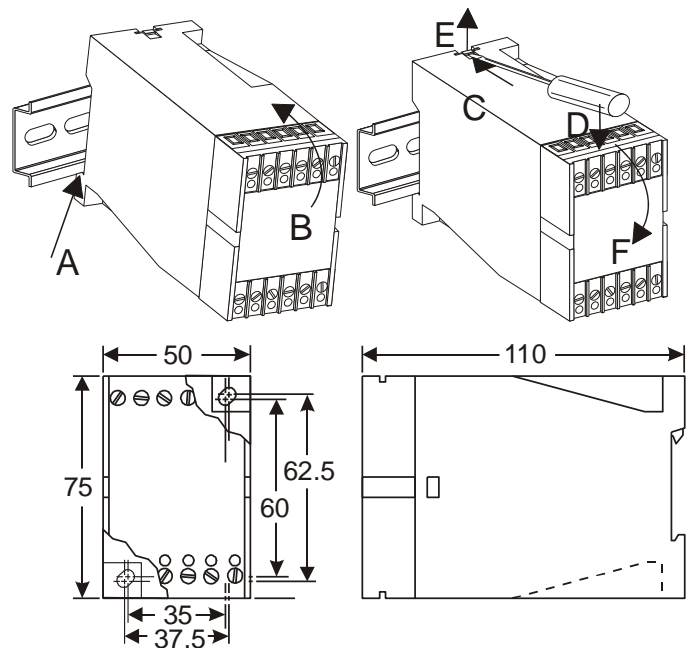

## Electrical Connection

### General

Connection to control panel wiring is through 12 screw terminals at the top and bottom of the front facia.

- Use a 3mm flat head screwdriver to loosen each terminal.
- Insert pre-stripped wires or narrow blade crimps from above or below, ensuring that the wires or crimps are fully home in the terminal holes
- Re-tighten each terminal screw and check that the wiring is secure.

General connection recommendations:

### Battery chargers

Some battery chargers feature significant ripple and switching noise on the DC output. This electrical interference can be imposed on the panel power supply and speed signal wires, with the potential to cause faulty operation of (and in extreme cases damage to) electronic control equipment.

Minimise the effects of charger output noise by using separate wiring 1) between charger output and battery terminals and 2) between battery terminals and panel DC supply rail.

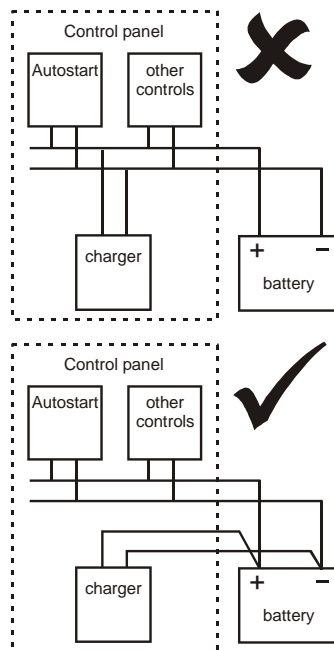

**External Slave Relays** are a recommended for all outputs (as shown right), either to achieve the required load switching capability, or to reduce wear and tear on internal relay contacts.

**Slave relay and solenoid coils** will naturally emit voltage spikes when de-energising, with the potential to cause faulty operation of, or damage to, electronic equipment.

Suppress relay and solenoid coils at source, using the manufacturer's recommended suppression network. DC coil relays may also be suppressed using a reversed biased flywheel diode as shown right.

### Positive outputs

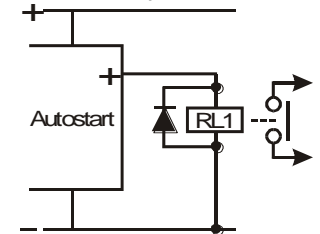

### Negative outputs

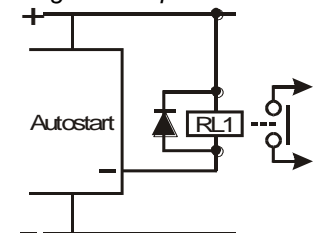

## Electrical Connection (cont.)

A typical connection of the 3ST is as follows:

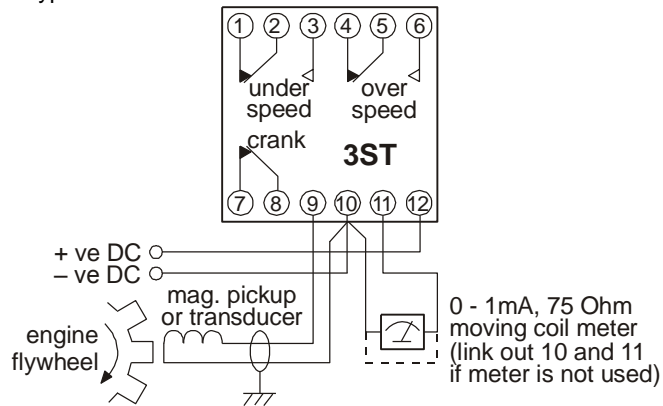

The functions of each terminal are:

### Pin Function/description

- 1 Underspeed (S2) Relay, Normally closed contact**
- 2 Underspeed (S2) Relay, Change-over contact**
- 3 Underspeed (S2) Relay, Normally open contact**

On standard units (where S2 is 'energised high'), the underspeed relay energises (2 closes to 3) and LED S2 lights when the actual speed is higher than the S2 setting.

When correctly calibrated, the relay will therefore de-energise (2 closes to 1) and LED S2 will go out during engine underspeed conditions. The relay is non-latching in operation.

The contacts may be used to drive generator contactor, fuel shutoff or alarm circuits. When using the output to provide fault alarm/shutdown, external provision must be made (e.g. using a timer) to override alarm activation during normal engine start-up.

- 4 Overspeed Relay (S3), Normally closed contact**
- 5 Overspeed Relay (S3), Change-over contact**
- 6 Overspeed Relay (S3), Normally open contact**

On standard units (where S3 is 'energised low'), this relay energises (5 closes to 6) and LED S3 lights when the actual speed is lower than the S3 setting.

When correctly calibrated, this relay will therefore de-energise (and LED S3 will go out) during overspeed conditions; the relay will also de-energise if the speed sensing input goes open circuit. The relay is non-latching in operation.

- 7 Crank Relay (S1), Normally closed contact**
- 8 Crank Relay (S1), Change-over contact**

On standard units (where S1 is 'energised high'), this relay energises (contacts open) and LED S1 lights when the actual speed is higher than the S1 setting.

This relay is therefore de-energised (contacts closed and LED S3 off) at initial power up, when the engine is stationary.

The closed contacts are typically used to drive a starter motor control circuit. The relay is non-latching in operation: to prevent re-engagement of the starter motor in the event of low engine speed, use an external, latching relay.

### 9 Speed sensing input (pickup or tacho)

Connect pin 9 to the positive/high output of the speed transducer (magnetic pickup or tacho generator). The negative/low transducer output or common return should be connected to the negative DC power supply (e.g. pin 10). Note: if the transducer coil is isolated from its mechanical body and the DC supply, the connection polarity is not normally important.

To minimise speed signal interference, the transducer wiring to pins 9 and 10 should use two core and shield cable, with the shield connected to ground at one end only.

The 3ST will operate with transducer signals of 0.5 to 80 VAC rms. For standard 3ST/1 and 3ST/2 units, the nominal transducer frequency (when the engine is running normally) may be between 1 and 8 kHz. For transducers with lower nominal frequencies, 'M' or 'L' variants of the 3ST are available to special order (see specification for frequency ranges).

### 10 Negative DC power supply / speed input / meter

### 12 Positive DC power supply

Connect these terminals to the DC power supply:  
18 – 32 VDC for 3ST/1 units  
9 – 16 VDC for 3ST/2 units

Pin 10 / battery negative must also be connected with the return wiring of the speed signal transducer and (if fitted) the calibration/RPM meter.

### 11 Calibration/RPM meter output

This output is designed for connection to an external meter, which may be used for two purposes: a) during set-up, as an aid to accurate calibration, and b) during normal operation, to indicate engine running speed.

Pin 11 gives a pulse width modulated signal, with the pulse width (and average current) increasing proportionately with speed transducer frequency. The circuit is designed to operate with a 0 – 1 mA, 75 Ohm (analog) moving coil meter. Digital meters are not recommended, because of the possibility of variable results when used with the pulse width modulated output.

When the 3ST is correctly calibrated and the engine is running normally, pin 11 gives a 0.75mA output. See section below for full details about calibration.

**Important:** Where a meter is not used (either when calibrating or in normal operation), pin 11 must be connected to battery negative, e.g. using a short wire link to pin 10.

# Speed Calibration

The 3ST measures engine/machine speed via a remote transducer, e.g. a magnetic pickup located next to an engine flywheel/gearwheel, or a tachometer generator.

The transducer output frequency is always proportional to engine or machine speed, but different transducers and engine types (e.g. with different speeds and numbers of flywheel teeth) will each give a different 'nominal' output frequency ('nominal' being the output frequency when the engine/machine is running at its normal speed).

Before use, each 3ST **MUST** therefore be calibrated for the specific engine/machine being used.



**WARNING: incorrect calibration may result in faulty operation of the 3ST and plant, with subsequent risk of personal injury and damage to plant machinery.**

Speed calibration is set using the four potentiometers on the front fascia. Calibration may be set a) during engine commissioning, using the actual speed transducer, or b) 'on the bench', using a signal generator to simulate the speed transducer at different engine speeds

Calibration is a two-stage process:

- 1) Calibration of the 3ST to the nominal transducer frequency ( $f_0$ ) using the **METER ADJUST** potentiometer. Accurate calibration requires the use of a suitable meter (as detailed in pin 11 electrical connection) but rough calibration can be achieved without a meter: both methods are detailed below.
- 2) Setting the crank release, underspeed and overspeed relay trip levels using potentiometers **S1**, **S2** and **S3**.

## Initial Set-up

- If calibrating 'on the engine', ensure that the engine/machine is stopped and cannot start (e.g. by isolating the engine starter motor).
- Connect the speed input, i.e. the transducer if calibrating on the engine, or an isolated signal generator if calibrating on the bench. Connect the positive/high signal to pin 9 and the negative/low signal to pin 10.
- Connect a calibration meter, if available - meter positive to pin 11 and meter negative to pin 10. If a meter is not available, connect pin 11 to pin 10 or negative DC
- Connect the (isolated) DC power supply; DC/battery positive to pin 12 and DC/battery negative to pin 10.

Note: leave the relay outputs (pins 1 to 8) open circuit.

## Nominal frequency calibration

The nominal calibration frequency ( $f_0$ ) is set using the front fascia **METER ADJUST** potentiometer. Adjustment of this pot. also affects the frequency settings and adjustment ranges of S1, S2 and S3. It is therefore important that the **METER ADJUST** potentiometer is set correctly, before any adjustment of the other 3 pots:

- Switch on the DC power supply.
- Manually start the engine and run it at normal speed, or switch on the signal generator and adjust the frequency to simulate the speed transducer output at normal

running speed: e.g. for a magnetic pickup, the nominal transducer frequency ( $f_0$ , in Hz) can be calculated as:

$$f_0 = \frac{\text{normal engine speed (RPM)} \times \text{no. of flywheel teeth}}{60}$$

For a stock 3ST,  $f_0 = 3000\text{Hz}$  (equivalent to a 1500RPM engine with a magnetic pickup and 120 teeth).

For accurate recalibration of  $f_0$ , use a meter (type and connection as detailed above):

- Turn the **METER ADJUST** potentiometer until the meter reads 0.75mA. Meter readings of less than 0.75mA indicate that the calibrated frequency is too high - turn the **METER ADJUST** pot. clockwise. Readings greater than 0.75mA mean that calibration is low - turn anticlockwise.

Where a meter is not available,  $f_0$  can be roughly set as follows:

- Turn potentiometer S2 (underspeed) 20 turns clockwise. This sets relay S2 to trip at around 100% of the nominal calibration.
- Turn potentiometer S3 (overspeed) 20 turns anti-clockwise. This sets relay S3 to trip at around 100% of the nominal calibration.
- Run the engine or switch on the signal generator and turn the **METER ADJUST** potentiometer until the S2 and S3 LEDs are just lighting/extinguishing. If only LED S2 is lit, the nominal calibration is likely to be too low - turn the **METER ADJUST** pot. anti-clockwise. If only LED S3 is lit, the nominal calibration is likely to be too high - turn the **METER ADJUST** pot. clockwise. If both or neither LEDs S2 or S3 are lit, the nominal calibration is roughly correct.

## Setting the trip relays

Adjustment of the three relay trip frequencies is via front fascia potentiometers S1, S2 and S3. Each is a 20-turn potentiometer: turn clockwise to increase the trip frequency.

In *percentage* terms, the adjustment range of each relay is fixed in relation to the nominal calibration ( $f_0$ ):

Trip relay	Adjustment range
S1 (CRANK):	10 – 50% of $f_0$
S2 (UNDERSPEED):	50 – 95% of $f_0$
S3 (OVERSPEED):	100 - 130% of $f_0$

The *absolute* settings and adjustment ranges (in Hz) therefore rise and fall with the setting of **METER ADJUST** potentiometer. Stock units are typically set as follows:

Trip relay	Nominal stock setting
S1 (CRANK):	35% of $f_0$
S2 (UNDERSPEED):	90% of $f_0$
S3 (OVERSPEED):	110% of $f_0$

If these percentage trip levels (with respect to the nominal calibration) are acceptable for the application, stock units' potentiometers S1, S2 and S3 will need little or no adjustment. (This assumes that the **METER ADJUST** pot is correctly set using a calibration meter, and that S1, S2 and S3 are not adjusted in the process.)

## Speed Calibration (cont.)

If, however, the S1, S2 or S3 trip levels do require adjustment or fine-tuning:

- **UNDERSPEED (S2):**  
Turn down the engine speed to the required underspeed trip level, or adjust the signal generator to simulate the transducer frequency. Turn S2 anti-clockwise (lowering the trip frequency) until LED S2 is lit, then clockwise until the LED just goes out.
- **OVERSPEED (S3):**  
Turn up the engine speed to the required overspeed trip level, or adjust the signal generator to simulate the transducer frequency. Turn S3 clockwise (increasing the trip frequency) until LED S3 is lit, then anti-clockwise until the LED just goes out (relay de-energised).
- **CRANK (S1):**  
Turn down the engine speed to the required crank cut-out level, or adjust the signal generator to simulate the transducer frequency. Adjust S1 anti-clockwise (decreasing the trip frequency) until LED S1 goes off, then clockwise until the LED just lights (relay energised).

### Completing set-up

After calibration 'on the bench', the 3ST may be disconnected. The calibration settings are retained as long as the potentiometers remain unadjusted.

If calibration is carried out during engine or panel commissioning, the following further connections must be made before operation:

- **Relay Outputs.** Connect the relay outputs (pins 1 to 8) to the appropriate control circuits (for crank release, underspeed trip and overspeed trip).
- **Meter.** If a meter has been used for calibration, it may be replaced with a short wire link (or connect pin 11 to DC negative). If a meter is suitably scaled, it can be used to indicate engine RPM during normal operation. The meter must be scaled to indicate 0 RPM at 0mA and normal running speed at 0.75mA.
- **Calibration label.** Stock units are supplied with a blank calibration label. If the calibration frequencies (in Hz) are known, write these figures on the label for future reference. The label and clear plastic cover should be fitted to the top side of the 3ST case.
- **Final checks.** With all control panel wiring connected, check that the 3ST and engine/machine operate as intended.

## Maintenance

Maintenance is limited to keeping the unit free from build-up of dust, dirt or moisture. The unit may be wiped with a clean, lint-free cloth, taking care not to adjust the front face potentiometers.

The 3ST contains no user serviceable parts and no attempt should be made to dismantle the unit. Attempts to dismantle the 3ST may result in internal component damage and will invalidate any outstanding warranty.

If the 3ST is moved to another control panel or used to control a different type of engine, note that the calibration settings and labelling are likely to need adjustment.

**ENOVATION CONTROLS CORPORATE HEADQUARTERS**  
5311 S 122ND EAST AVENUE  
TULSA, OK 74146

**ENOVATION CONTROLS LTD. – UNITED KINGDOM**  
CHURCH ROAD, LAVERSTOCK  
SALISBURY, SP1 1QZ, UK

**SUN MURPHY INTERNATIONAL TRADING (SHANGHAI) CO., LTD**  
B15 ROOM, 6# BUILDING, 351 SIZHUAN ROAD  
SONGJIANG DISTRICT, SHANGHAI 201601, CHINA

**ENOVATION CONTROLS INDIA PVT. LTD.**  
301, 3RD FLOOR, KRSNA CHAMBERS,  
11 GALAXY GARDENS, NORTH MAIN ROAD,  
KOREGAON PARK, PUNE 411001,  
MAHARASHTRA, INDIA

### U.S. SALES & SUPPORT

PHONE: 918 317 4100  
EMAIL: SALES@ENOVATIONCONTROLS.COM  
WWW.ENOVATIONCONTROLS.COM

### MURPHY INDUSTRIAL PANEL DIVISION

PHONE: 918 317 4100  
EMAIL: IPDSALES@ENOVATIONCONTROLS.COM

### INTERNATIONAL SALES & SUPPORT

**EUROPE, MIDDLE EAST, AFRICA**  
PHONE: +44 1722 410055  
EMAIL: SALES@ENOVATIONCONTROLS.EU

**CHINA**  
PHONE: +86 21 6237 5885  
EMAIL: APSALES@ENOVATIONCONTROLS.COM

**INDIA**  
PHONE: +91 91581 37633  
EMAIL: INDIA SALES@ENOVATIONCONTROLS.COM



FM 28221 (Tulsa, OK - USA)  
FM 29422 (UK)