

S10 series

Automatic Battery Chargers

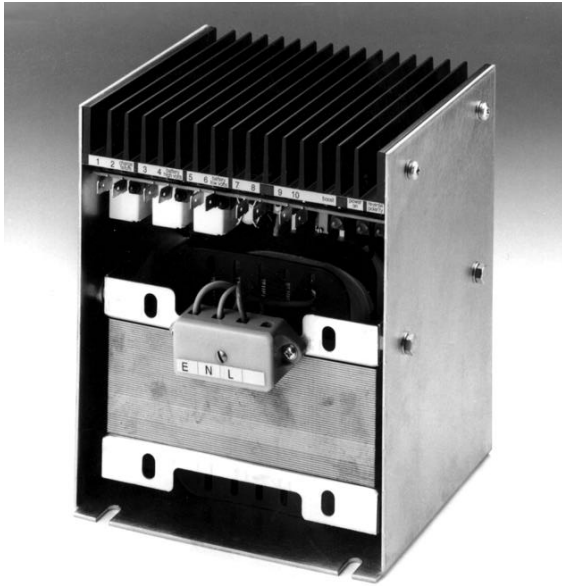

Description

The S10 is a fully automatic battery charger, designed specifically for the rapid charge recovery of standby engine battery packs.

When battery voltage is low, the S10 delivers a constant current to the battery, up to a maximum of 10 Amps. Optimum current is maintained until the battery voltage has recovered to the required 'float' level. The charger then reverts to constant voltage mode, maintaining the battery at float voltage without overcharging, and supplying any DC static load current.

The S10 also features a 'boost' mode, which increases the DC output voltage. Boost mode is selected by linking two terminals, and is indicated by an amber LED.

Protection against reverse polarity DC connection is by use of a fuse and red warning LED. Output short-circuit protection is also fitted as standard.

Three relay outputs and LED indicators provide signalling of 'low battery volts', 'high battery volts' and 'charge fail' faults. The low battery volts output has an on-board time delay, preventing fault signalling during normal engine cranking.

The S10 has an anodised steel, open chassis case, designed for mounting in an enclosed control panel. Electrical connection of the DC output, boost link and fault relays is via 1/4 inch (6.3mm) blade terminals on the main circuit board. AC power supply is 110 VAC or 240 VAC (please specify), connected through a separate, shrouded screw terminal block.

Applications

The S10 is primarily designed for use with standby engine/generator batteries, but may be used to maintain battery charge in a wide range of unattended DC power applications. Note: the S10 should *not* be used with low capacity (less than 50 A/h) batteries or sealed (recombination type) lead acid cells.

- **Rapid charge recovery:
10 Amp maximum output**
- **Design optimised for standby engine applications**
- **12V or 24V, lead acid or Ni-Cd**
- **Boost mode**
- **3 fault relay outputs**

Product Specification

Power supply:	
operating voltages	240 V AC or 110 V AC (specify), +/- 10%, 50/60 Hz.
DC charge output:	
nominal output voltage	12 or 24 VDC (specify), see chart overleaf for calibration
voltage stability	+/- 1% of nominal
maximum current output	10 Amps
current stability	+/- 2% of nominal
Fault relay outputs: <i>(ratings for resistive load)</i>	
charge fail and low battery volts	volt free SPNC contacts
high battery volts	volt free SPNO contacts
	all rated 5 A @ 30 V DC see chart overleaf for trip level calibration
General:	
operating temperature	-10 to +55 °C
overall dimensions (h x l x d)	185 x 145 x 155 mm
weight	approx. 8.0 Kg

Warranty

A two year limited warranty on materials and workmanship is given with this Murphy product. Details are available on request and are packed with each unit.

Electrical connection

F1 ratings (type T, anti-surge):

S1012, 240V: 1.5A
110V: 3.15A
S1024, 240V: 3.15A
110V: 6.3A

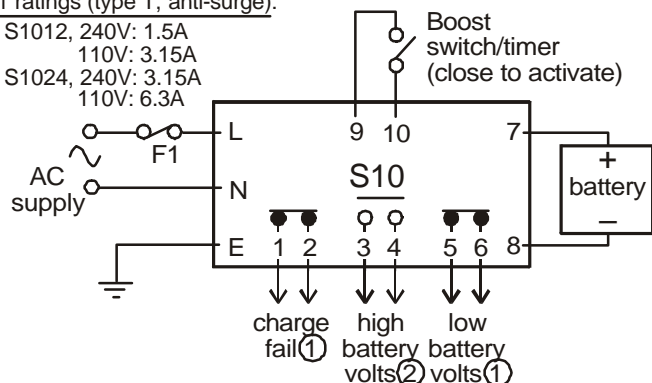

- ① Relay de-energises (contacts close) on fault
② Relay energises (contacts close) on fault

Calibration

Battery type		float volts (VDC)	boost volts (VDC)	low volts fault output (VDC)	high volts fault output (VDC)
12V	Lead acid (6 cells)	13.6	14.1	10.0	15.1
	Ni-Cd (10 cells)	14.2	15.6	10.0	16.6
24V	Lead acid (12 cells)	27.2	28.4	20.0	29.4
	Ni-Cd (18 cells)	25.6	28.1	20.0	29.1
	Ni-Cd (20 cells)	28.4	31.2	20.0	32.2

How to order

When ordering, please specify:-

Stock Number	Model	Supply voltage, calibration
41.70.0003	S1012/CLA	110VAC, 12V lead acid
41.70.0088	S1012/CNC10	110VAC, 10 cell NiCd
41.70.0004	S1012/DLA	240VAC, 12V lead acid
41.70.0043	S1012/DNC10	240VAC, 10 cell NiCd
41.70.0005	S1024/CLA	110VAC, 24V lead acid
41.70.0089	S1024/CNC18	110VAC, 18 cell NiCd
41.70.0090	S1024/CNC20	110VAC, 20 cell NiCd
41.70.0006	S1024/DLA	240VAC, 24V lead acid
41.70.0066	S1024/DNC18	240VAC, 18 cell NiCd
41.70.0015	S1024/DNC20	240VAC, 20 cell NiCd

Dimensions

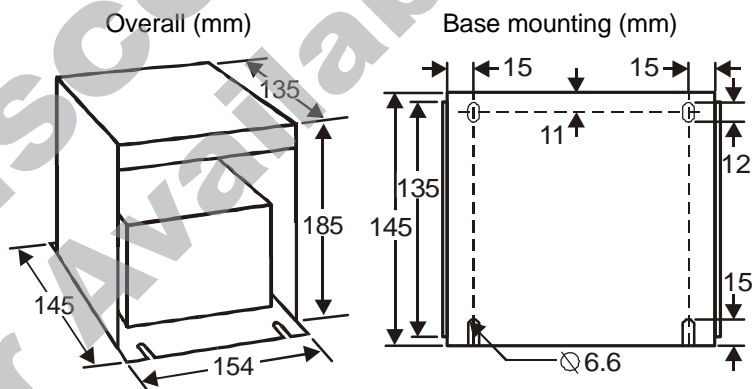

FWMurphy

PO Box 470248
Tulsa, Oklahoma 74147, USA
tel: (918) 627 3550
fax: (918) 664 6146
email: sales@fwmurphy.com
web: www.fwmurphy.com



CONTROL SYSTEMS AND SERVICES DIVISION
PO Box 1819, Rosenberg, Texas 77471, USA
tel: (281) 342 0297
fax: (281) 341 6006
email: sales@fwmurphy.com

MURPHY DE MEXICO S.A. DE C.V.
Blvd. Antonio Rocha Cordero 300, Fracción del
Aguaje San Luis Potosí, S.L.P. México 78384
tel: + 52 48 206264
fax: + 52 48 206336
email: ventasmex@murphymex.com.mx
web: www.murphymex.com.mx

FRANK W. MURPHY LTD.
Church Rd, Laverstock, Salisbury, SP1 1QZ, UK
tel: +44 1722 410055
fax: +44 1722 410088
email: sales@fwmurphy.co.uk
web: www.fwmurphy.co.uk

For service in French:-
Pour service en français:-
tél: +44 1722 410697
fax: +44 1722 410088
email: france@fwmurphy.co.uk
web: www.fwmurphy.co.uk/francais.htm

MURPHY SWITCH OF CALIFORNIA
41343 12th Street West,
Palmdale, CA 93551-1442, USA
tel: (661) 272 4700
fax: (661) 947 7570
email: sales@murphyswitch.com
web: www.murphyswitch.com

MACQUARRIE CORPORATION
1620 Hume Highway,
Campbellfield, Victoria 3061, Australia
tel: +61 3 9358 5555
fax: +61 3 9358 5558
email: murphy@macquarrie.com.au

In order to consistently bring you the highest quality, full featured products, we reserve the right to change our specifications and designs at any time.