

Autostart AS730S Generator Controller V1.05 – V1.09(a)

mi5264
revision E, 29th July 2005
catalogue section 75

Installation Instructions

Section A: Installation and Wiring



Please read the following information before installing. A visual inspection of this product for damage during shipping is recommended before installation. It is your responsibility to ensure that qualified mechanical and electrical technicians install this product. If in doubt, please contact your local Murphy representative.

GENERAL INFORMATION

WARNING

BEFORE BEGINNING INSTALLATION OF THIS MURPHY PRODUCT

- ✓ Disconnect all electrical power to the machine
- ✓ Make sure the machine cannot operate during installation
- ✓ Follow all safety warnings of the machine manufacturer
- ✓ Read and follow all installation instructions



Description

The Autostart AS730S is part of the AS7XX family of controls, designed for the automatic or manual control of a standby diesel generator. The unit features over 50 programmable settings - timers, inputs, outputs, control options and fault protections - allowing it to be used in a wide variety of generator applications.

Operator control is by 4 front facia push keys, with a backlit liquid crystal display (LCD) for indication of plant status, measured parameters and fault conditions. All units feature an RS232 communication port, providing optional monitoring, control and programming from Murphy software (running on a local or remote PC).

The AS730 is designed for front-of-panel mounting through a DIN standard aperture, 140mm (5½") wide by 92mm (3⅝") tall. Electrical connection is at the rear, via 'two-part' type terminal blocks.

This document details the panel installation and electrical connection of the AS730S fitted with firmware versions V1.05 - V1.09(a), standard models as detailed opposite. Additional information on the operation, specification and programming of the AS730 and AS7xx family of controls may be found in the following documents:-

Doc. ref.	Title
ms5261	AS730 bulletin and specification
mi5265	AS7xx installation section B: programming
mi5266	AS7xx and AS7CK PC software

The above information is available on request from your Murphy representative, or from the 'products' section of our website www.fwmurphy.co.uk.



FW Murphy
PO Box 470248
Tulsa, Oklahoma 74147, USA
tel: +1 918 317 4100
fax: +1 918 317 4266
email: sales@fwmurphy.com
web: www.fwmurphy.com

CONTROL SYSTEMS & SERVICES DIVISION
PO Box 1819, Rosenberg, Texas 77471, USA
tel: +1 281 633 4500
fax: +1 281 633 4588
email: sales@fwmurphy.com

MURPHY DE MEXICO S.A. DE C.V.
Blvd. Antonio Rocha Cordero 300, Fracción del
Aguaje San Luis Potosí, S.L.P. México 78384
tel: +52 444 8206264
fax: +52 444 8206336
Villahermosa office tel: +52 993 3162117
email: ventas@mex.murphy.com
web: www.murphy.com.mx

INDUSTRIAL PANEL DIVISION
PO Box 470248
Tulsa, Oklahoma 74147, USA
tel: +1 918 317 4100
fax: +1 918 317 4266
email: sales@fwmurphy.com
web: www.fwmurphy.com

FRANK W. MURPHY LTD.
Church Rd, Laverstock, Salisbury, SP1 1QZ, UK
tel: +44 1722 410055
fax: +44 1722 410088
email: sales@fwmurphy.co.uk
web: www.fwmurphy.co.uk



GENERAL INFORMATION (cont.)

Familiarisation

Unpacking

Each AS730 is supplied complete with:-

- 2 terminal blocks (connected into the rear of the unit)
- 2 mounting clamps
- these instructions

Model numbers

The model reference is labelled on the top side of each unit (as shown below): this should be checked before installation to ensure compatibility with the application.

Standard units have model reference AS730S. Non-standard variations have a numbered suffix to the model reference (e.g. AS730S/001). For full technical details of AS730 special variations, please contact your local Murphy representative.

Front Facia



32 character, back-lit LCD (Liquid Crystal Display)

LED indicators: Auto (green), Manual (amber)

Operator control keys:-

On/mode: turns on unit and allows selection of Auto or manual modes

Page: used for scrolling of display information

Select: used during program mode

Off: powers down unit and resets a fault condition

Rear Facia

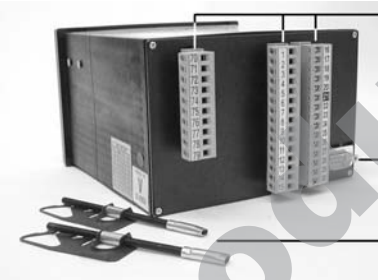

3 x connectors (two-part, screw terminal blocks), numbered 1 – 15, 16 – 30 and 70 – 79.

Communication port

Mounting clamps x 2

Top Facia Labelling



Model reference

Electrical connection details

Specifications

Power supply:

Operating voltage: steady state range	5 – 40 V DC continuous
crank brown-out	to 0 V for >=100mS
Current consumption	typically 200 mA

Inputs:

DC inputs:-	
positive input defined as:	80% to 100% of battery +ve
negative input defined as:	-1V to +2V w.r.t. battery -ve
Input 1 (oil pressure) and	switch (open or closed) or analogue
Input 2 (engine temperature)	(Murphy, Datcon, VDO 5 or 7 bar),
	wired to -ve DC
Inputs 3 - 5	switch (open or closed),
	wired to +ve or -ve DC
Generator AC inputs:-	
operating voltage range	90 – 300 V AC rms L-N
gen. frequency measurement range	0 – 99 Hz.
gen. frequency display accuracy	<= 2% of full scale
gen. frequency display resolution	1 Hz.
Magnetic pickup:	
operating voltage range	7 – 80 V AC rms
frequency measurement range	0 – 10 kHz.
generator RPM display accuracy	<= 2% of full scale
generator RPM display resolution	10 RPM
AC current sensing inputs:	
operating range	designed for use with 5 Amp CT's
	primary ratings 10 to 5000 Amps

Outputs:

Start and fuel relays	SPNO contacts (switched +ve)
	rated 16 A max. @ 24 V DC
Programmable outputs 1 – 3	- ve DC (open collector transistor)
	250 mA max. @ 33 V DC
Programmable output 4	- ve DC (switched relay)
	5 A max. @ 24 V DC
Programmable output 5	+ ve DC (switched relay)
(default setting: Common Alarm)	5 A max. @ 24 V DC
Programmable output 6	volt free SPNO relay
(default setting: Gen. Contactor)	5 A max. @ 240 V AC

Physical:

Overall dimensions (W x H x D)	144 x 96 x 162 mm
Panel cut-out size (W x H)	DIN standard 140 x 92 mm
Weight	approx. 720 g
Operating ambient temperature	-10 to +55 °C

INSTALLATION INFORMATION

Panel Mounting

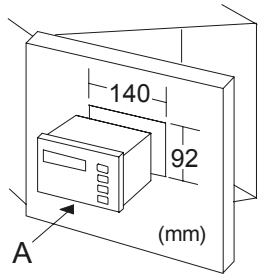

The AS730 is mounted in the front of a control panel through a DIN standard aperture, 140mm (5½") wide by 92mm (3⅝") tall.

With the mounting clamps removed, insert the unit through the front of the panel cut-out (A).

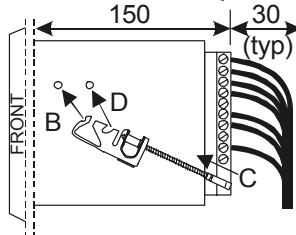

The case extends to 150mm (6") behind the panel front; an extra 30mm (1.25") minimum should typically be allowed for the connection of the wiring harness.

Working behind the panel front, fit both mounting clamps to pairs of studs on each side of the case. Locate the clamp on to the front stud (B), compress the clamp by pushing on the screw (C) and push the clamp upwards to locate on to the rear stud (D).

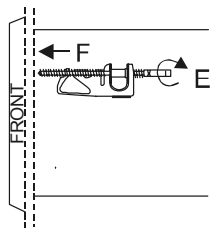

With both clamps fitted, tighten the screwed pins (E) so that they move forward and secure the unit to the rear of the panel facia (F). The case design allows a panel thickness of up to 8mm.

Programming

The AS730 has over 50 programmable options, including settings for timers, trip levels, alarms and control options. These **MUST** be programmed correctly before the Autostart can be tested or used to control an engine.



WARNING: Failure to correctly program each unit can result in damage to Autostart, engine and other equipment.

The AS730 may be programmed in one of two ways:-

1) Using the front facia keys

To access 'program mode':-

- Connect the DC power supply (negative to pin 1, positive to pin 3)
- Press the ON/MODE key.
- Immediately after the display lights, press and hold the SELECT key.
- If the display reads 'Enter PIN' (personal identification number), use the \triangleright , \triangle and \triangleright keys to change the display to the correct PIN, then press \triangleleft .
- Once the correct PIN is entered (or if no PIN entry is required), Autostart displays the first programmable function ('Start delay').
- Use the display and front facia keys (indicated by red arrows) to step through and edit each function in turn.

2) Using Murphy PC software model AS7CK

The PC software allows program 'profiles' to be created, edited and downloaded to the AS710 over a communication link, quickly and error free. The PC communication link is made through the D-connector at the rear, and requires an RS232 interface unit and lead (supplied separately):-

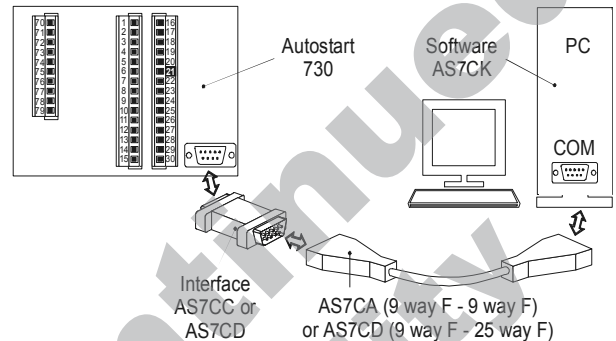

For detailed information about program functions and options, please refer to document mi5265. For information about communication links and PC software, please see document mi5266.

Electrical Connection

General

Electrical connection is through 3 screw terminal blocks at the rear of the unit; the 3 connectors are of a 'two-part' construction, labelled 1 -15, 16 - 30 and 70 - 79. Use a 3mm (1/8") flat head screwdriver to loosen and tighten each screw terminal.

Before connection or disconnection, ensure the unit is switched off and that all DC and AC power supplies are isolated.



WARNING: connection to or disconnection from live wiring can cause damage to internal components.

General wiring recommendations

Murphy make the following recommendations:-

Terminal blocks

- Ensure that no more than 2 wires are inserted into each screw terminal
- Ensure that terminal blocks are fully pushed home into Autostart rear facia receptacles.

Battery chargers

Some battery chargers feature significant ripple and switching noise on the DC output. This electrical interference can be imposed on the panel power supply and control lines, with the potential to cause mal-operation of (and in extreme cases damage to) electronic control equipment.

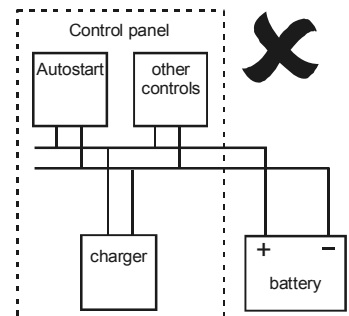

INSTALLATION INFORMATION (cont.)

Minimise the effects of charger output noise by using separate wiring 1) between charger output and battery terminals and 2) between battery terminals and panel DC supply rail.

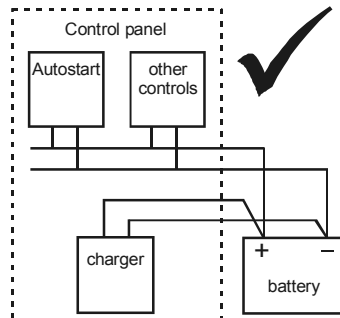

External Slave Relays are a recommended connection on all outputs (as shown right), either to achieve the required load switching capability, or to reduce wear and tear on internal relay contacts.

Slave relay and solenoid coils will naturally emit voltage spikes when de-energising. Suppress this interference at source using the relay manufacturer's recommended suppression network. DC coiled relays can also be suppressed using a reversed biased flywheel diode as shown right.

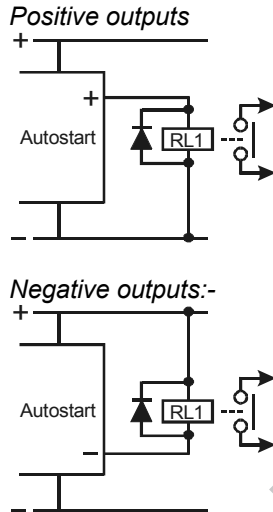

Terminal Functions

A typical wiring diagram for the AS730 is shown on page 5 of this document. The functions of each connection are as follows:-

Terminal block 1 - 15

Pin Function

- 1 Negative DC power supply**
- 3 Positive DC power supply**

Autostart will operate with any clean, noise-free supply in the range 5 to 40 V DC (normally the engine's 12V or 24V battery). Connect a 5 Amp anti-surge fuse in the positive DC line (pin 3). See also 'general wiring recommendations' above regarding battery chargers. In normal operation, Autostart measures its own DC supply voltage and displays this on the front facia. Autostart also provides warnings if the supply falls outside programmed under and over DC voltage limits.

2 Charge fail input

A 'charge fail' warning may occur if pin 2 is switched to negative DC. The following program options are available:-

- a) Charge 'alternator'. Connect pin 2 to the charge alternator warning lamp (WL) terminal – note that Autostart provides the necessary charge excitation current. The 'WL crank cut' program settings allows the option of an automatic crank release above a pre-set charge alternator voltage.

- b) 'Mains charger'. Connect pin 2 to the 'charge fail' output of a Murphy BC700 series charger, or direct to negative DC via relay contacts which close on fault.
- c) 'Not used' (or - -). Use this option if a charge fail alarm is not required, and leave pin 2 open circuit.

4 Positive DC (feed for relays)/Emergency stop

This positive DC connection provides a feed for the Fuel and Start outputs (pins 22 and 23). If required, emergency stop switches (push to break, mechanically latching types) may be wired between positive and pin 4: Autostart shuts down the engine and indicates 'emergency stop' if pin 4 is made open circuit.

5 Magnetic pickup

Allows the optional use of a magnetic pickup (and engine flywheel) for sensing engine speed. Connect one pickup terminal to pin 5, the other terminal to pin 1 or negative DC. Use a two core and shield cable for inter-connection, with the shield grounded at one end only.

Before use, the AS730 must be programmed with the correct number of flywheel teeth, and with correct trip levels (in engine RPM) for crank release, underspeed and overspeed.

6 Programmable output 1

7 Programmable output 2

9 Programmable output 3

10 Programmable output 4

These outputs may be programmed to give a range of signalling and control 'actions', e.g. 'preheat', 'engine running', 'overspeed', etc. Please refer to programming literature mi5265 for full details.

Electrically, all 4 terminals give a negative DC output when active. Outputs 1 to 3 are open collector transistor types, rated to a maximum current of 300mA. Output 4 is relay based, giving a switched negative output of up to 5 Amps.

The connection of slave relays is recommended, as detailed above in 'general wiring recommendations'.

8 A800 enable output

Pin 8 may be used to give a 'seam free' operation with the Murphy A800 alarm/annunciator unit. The output may be connected directly to the A800 enable input: the A800 fault/warning inputs are only then enabled once the Autostart detects that the engine is running. No attempt should be made to connect pin 8 to anything other than an A800 enable circuit.

11 Remote start/mains fail input

Use this input to initiate an automatic engine start in AUTO mode. Connect the switch contact between pin 11 and battery positive, and program the unit to start on opening or closing contact as required.

12 No connection

13 No connection

14 No connection

15 No connection

INSTALLATION INFORMATION (cont.)

Terminal block 16 – 30

16 Input 1: (low) oil pressure (LOP)

17 Input 2: (high) engine temperature (HET)

Sender (analogue) inputs:-

Pins 16 and 17 may be used with one of several types of oil pressure and engine temperature resistive sender - see document mi5265 for details of the sender types permitted.

Two wire senders (not ground return senders) should be used for maximum accuracy. Connect one sender wire to the input; connect the second sender wire to battery negative, as close to Autostart pin 1 as possible.

When senders are used, Autostart displays engine temperature and oil pressure during normal operation, and permits the programming of separate levels for warnings (pre-alarms) and shutdowns.

Switch (digital) inputs:-

The inputs may also be used with fault switch contacts. Connect the contact between each input and battery negative, and program each input to activate on 'closed to negative' or 'open from negative' as required. An active input causes an immediate engine shutdown. Where a fault contact is used, oil pressure and/or engine temperature is not displayed. Senders or switch contacts **MUST** be connected to ensure correct operation. Open circuit senders may result in 'sender fault' warning messages. Autostart also checks the oil pressure input state before cranking: if a 'high oil

pressure' is measured, the AS730 does not crank the engine and displays 'BAD OIL PRESSURE'.

18 Input 3 (programmable)

19 Input 4 (programmable)

20 Input 5 (programmable)

These inputs may be used with switch contacts to trigger a range of programmable 'actions', e.g. shutdown fault, warning fault, lamp test, manual restore (of mains), etc. Full details of program 'actions' can be found in document mi5265.

Connect the switch contact between each input and battery positive or negative, and program each input to activate as required (open/closed/positive/negative).

21 Index pin (no connection)

22 Fuel output

23 Starter output

These are positive DC outputs, rated to 16 Amps, for the control of engine fuel and starter motor circuits. Connection of slave relays is recommended, as detailed above in 'general wiring recommendations'.

24 Programmable output 5

(default setting: 'common alarm')

Pin 24 is a positive DC relay output, rated to 5 Amps. With its default 'common alarm' setting, the output activates during any fault (warning or shutdown). The output can, however, be programmed to give other 'actions', as for inputs 1 to 4.

TYPICAL CONNECTION (mains fail generator application)

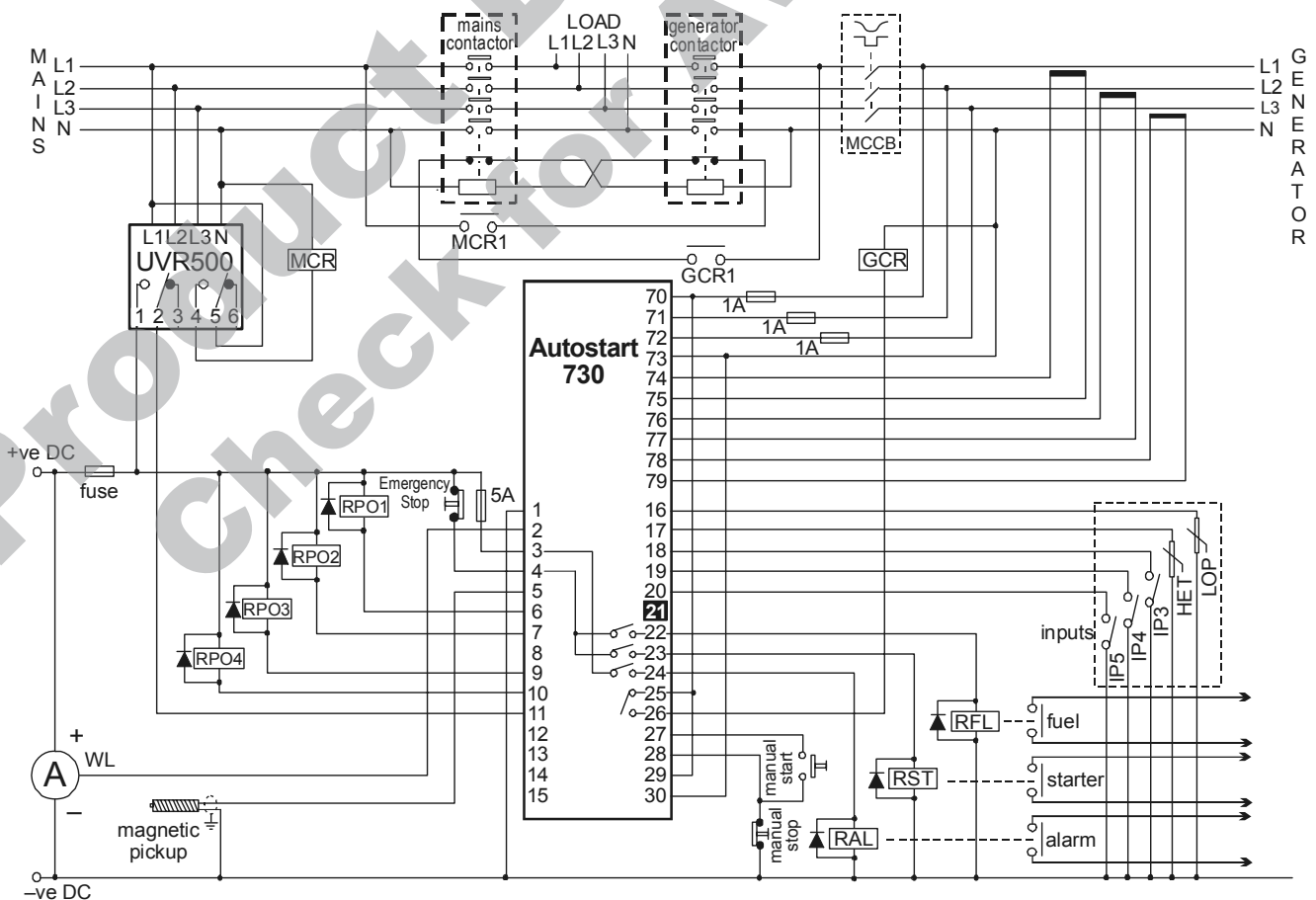

INSTALLATION INFORMATION (cont.)

25 Programmable output 6 (Normally Open contact)

26 Programmable output 6 (Change-over contact) (default setting: 'gen. contactor')

Output 6 is a volt-free set of normally open relay contacts, which can be programmed with the same range of 'actions' as outputs 1 to 5.

With its default 'gen. contactor' action, the output is typically used to control a generator contactor coil circuit. It will activate (contacts close) when:-

- a) generator voltage is above the program trip level
- b) generator frequency/speed is above the programmed trip level
- c) oil pressure is OK, and
- d) after the 'warm-up' delay time has expired.



These terminals may be wired to panel push-buttons as shown above, allowing operator control of engine starting and stopping when the unit is in 'manual' mode. Alternatively, hard-wire pins 27 and 28 to battery negative to give an immediate engine start when selecting manual mode.

29 Generator Live

30 Generator Neutral

Connect these terminals to one phase of the generator AC (50/60Hz). Line to neutral or line to line connections may be used, so long as the voltage does not exceed 300VAC. Connect a 1 Amp anti-surge fuse in series with the generator live terminal (pin 29).

The AS730 uses these terminals to measure generator frequency, which is needed for the correct operation of automatic crank release, the 'generator contactor' output and overspeed trip.

70 Generator volts L1

71 Generator volts L2

72 Generator volts L3

73 Generator Neutral

The AS730 uses these inputs to sense generator AC voltage. The AS730 may be programmed for:-

- 3 phase and neutral systems (connect all terminals),
- 2 phase and neutral (connect pins 70, 71 and 73), or
- single phase (connect pins 70 and 73 only).

An AC neutral must always be connected. The inputs can withstand a maximum phase to neutral voltage of 300 VAC rms. Use a 1 Amp anti-surge fuse in series with each connected phase (pins 70, 71 and 72).

The AS730 may also be programmed to display voltage as 'phase to neutral' (left to right, L1-N, L2-N, L3-N) or 'phase to phase' (left to right L1-L2, L2-L3, L3-L1).

Note: one (any) phase and neutral must also be connected to pins 29 and 30 (for measurement of AC frequency - see section above).

74 CT L1

75 CT L1 return

76 CT L2

77 CT L2 return

78 CT L3

79 CT L3 return

These inputs measure 3 phase generator current.

Each input pair is designed for use with a 5 Amp full scale current transformer (CT). Before the AS730 can correctly measure and display generator current, it must be correctly programmed with the full scale primary rating of the CTs.

Warranty and Maintenance

This unit is supplied with a 2 year warranty on parts and workmanship. Details are available on request and are supplied with each unit.

The AS730 contains no user-serviceable parts. Maintenance is therefore limited to the following preventative checks:-

- Check that the rear terminal blocks are pushed home fully, and that the wiring to screw terminals is secure.
- Check that the Autostart is securely clamped in the front of panel aperture, and kept free from ingress of water or build up of excessive dust/dirt. The front facia label and casing may be wiped with a clean, damp cloth. **Do not** use cleaning solvents.

Fixing clamps and terminal blocks are available as spare components, as are the range of communication accessories:-

Stock code	Model ref	Description
76.70.0124	KEY/CLAMPS	1 pair of mounting clamps
76.70.0121	AS7TBA	Terminal block 1 - 15
76.70.0122	AS7TBB	Terminal block 16 - 30
76.70.0123	AS7TBD	Terminal block 70 - 79
76.70.0018	AS7CA	Comms lead (null modem), 9 way (interface) to 9 way (PC)
76.70.0019	AS7CB	Comms lead (null modem), 9 way (interface) to 25 way (PC)
76.70.0020	AS7CC	Interface, Autostart to RS232 local communication
76.70.0021	AS7CD	Interface, Autostart to RS232 modem communication
76.70.0203	AS7CK	PC comms software (also available free of charge from the Downloads section of www.fwmurphy.co.uk)

In the event of a fault or technical query, please contact your Murphy representative for technical support. Technical documents are also available from the Products sections of our web-site www.fwmurphy.co.uk



FW Murphy
PO Box 470248
Tulsa, Oklahoma 74147, USA
tel: +1 918 317 4100
fax: +1 918 317 4266
email: sales@fwmurphy.com
web: www.fwmurphy.com

CONTROL SYSTEMS & SERVICES DIVISION
PO Box 1819, Rosenberg, Texas 77471, USA
tel: +1 281 633 4500
fax: +1 281 633 4588
email: sales@fwmurphy.com

MURPHY DE MEXICO S.A. DE C.V.
Blvd. Antonio Rocha Cordero 300, Fracción del
Aguaje San Luis Potosí, S.L.P. México 78384
tel: +52 444 8206264
fax: +52 444 8206336
Villahermosa office tel: +52 993 3162117
email: ventasfwmex@fwmurphy.com.mx
web: www.murphymex.com.mx

INDUSTRIAL PANEL DIVISION
PO Box 470248
Tulsa, Oklahoma 74147, USA
tel: +1 918 317 4100
fax: +1 918 317 4266
email: sales@fwmurphy.com
web: www.fwmurphy.com

FRANK W. MURPHY LTD.
Church Rd, Laverstock, Salisbury, SP1 1QZ, UK
tel: +44 1722 410055
fax: +44 1722 410088
email: sales@fwmurphy.co.uk
web: www.fwmurphy.co.uk



In order to consistently bring you the highest quality, full featured products, we reserve the right to change our specifications and designs at any time.