

Autostart AS705S Generator Controller V1.00 – V1.06(a)

mi5396
revision E, 1st June 2010
catalogue section 75

Installation Instructions

Section A: Installation and Wiring



Please read the following information before installing. A visual inspection of this product for damage during shipping is recommended before installation. It is your responsibility to ensure that qualified mechanical and electrical technicians install this product. If in doubt, please contact your local Murphy representative.

GENERAL INFORMATION

WARNING

BEFORE BEGINNING INSTALLATION OF THIS MURPHY PRODUCT

- ✓ Disconnect all electrical power to the machine
- ✓ Make sure the machine cannot operate during installation
- ✓ Follow all safety warnings of the machine manufacturer
- ✓ Read and follow all installation instructions



Description

The Autostart AS705S is part of the AS7XX family of controls, designed for use in the automatic or manual control of a standby diesel generator, pump or other engine driven equipment. The unit has over 50 programmable features – timers, inputs, outputs, control options and fault protections – allowing it to be used in a wide variety of engine applications.

Operator control is by a 3 way keyswitch or rotary switch (off, auto and manual). Indication of plant status and fault conditions is by 17 front facia LED indicators; 5 of these LEDs may be programmed and labelled to customer requirements. All units feature a communication port, providing optional monitoring, control and programming from a local PC and Murphy software.

The AS705S is designed for front of panel mounting through a DIN standard 92 x 92 mm aperture. Electrical connection is at the rear, via a pair of two-part type screw terminal blocks.

This document details the panel installation and electrical connection of the AS705S (standard versions as detailed opposite) fitted with firmware versions V1.00 – V1.06(a). Additional information on the operation, specification and programming of the AS705S and AS7xx family of controls can be found in the following documents:-

Doc. Ref.	Title
ms5258	AS705S bulletin and specification
mi5265	AS7xx installation section B: programming
mi5266	AS7xx and AS7CK PC software

The documents above are available on request from your Murphy representative, or from the 'products' section of our website www.fwmurphy.co.uk

Familiarisation

Unpacking

Each AS705S is supplied complete with:-

- 2 terminal blocks (connected into the rear of the unit)
- 2 keys (keyswitch versions only).
- 2 mounting clamps
- 1 custom label sheet
- these instructions

Model numbers

The model variation is labelled on the top side of each unit (as shown overleaf), and should be checked before installation to ensure compatibility with each application. Standard models are:-

Model	Stock code	Description
AS705SKD	76.70.0065	AS705S with keyswitch, 230VAC nominal generator voltage.
AS705SRD	76.70.0037	AS705S with rotary (knob) switch, 230VAC nominal voltage

Special build variants have a numbered suffix to the model reference e.g. AS705SKD/001. For full details of special models, please contact your Murphy representative.

GENERAL INFORMATION (cont.)

Familiarisation (cont.)

Front Facia

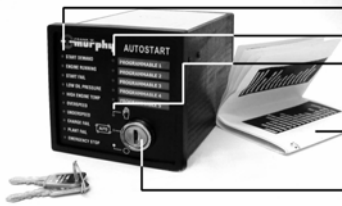

- LED indicators:-
- Preset x 10
 - Programmable x 5
 - Auto mode x 1
 - Manual mode x 1
- Custom label sheet
- 3 position operating mode switch (keyswitch shown):-
- Off/reset
 - ⏻ Auto
 - ✋ Manual

Rear Facia

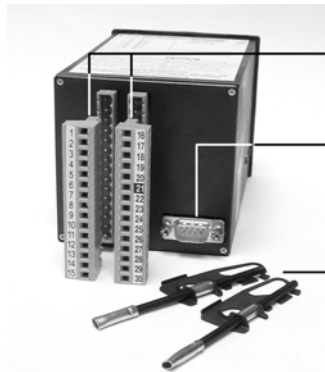

- 2 x 15 way, two-part connectors, numbered 1 – 15 and 16 – 30
- Communication port
- Mounting clamps x 2

Top Facia Labelling



- Model reference
- Electrical connection details

Specifications

Power supply:	
Operating voltage: steady state range crank brown-out	5 to 40 V DC continuous to 0V for <= 100 mSec
Current consumption	typically 150 mA
Inputs:	
DC inputs (inputs 1 - 5, remote start)	
positive input voltage range	80% to 100% of battery +ve
negative input voltage range	-1V to +2V from battery -ve
Generator AC input:-	
operating voltage range	90 to 300 V AC rms
frequency measurement range	0 to 99 Hz.
Magnetic pickup:-	
operating voltage range	7 to 80 V AC rms
frequency measurement range	0 to 10 kHz
Outputs:	
	<i>(all ratings for resistive load)</i>
Start and fuel relays	positive DC (switched relay) rated 16A max. @ 24V DC
Programmable outputs 1 to 3	negative DC (semiconductor) rated 250mA max. @ 33 VDC
Programmable output 4	negative DC (switched relay) rated 5A max. @ 24V DC
Programmable output 5 (default setting: Common Alarm)	positive DC (switched relay) rated 5A max. @ 24V DC
Programmable output 6 (default setting: Gen. contactor)	volt free SPNO relay contacts rated 5A max. @ 240V AC
Auto & Manual outputs	positive DC, 250mA max.
Off/reset output	negative DC, 250mA max.
Physical:	
Overall dimensions (W x H x D)	96 x 96 x 162 mm
Panel cut-out size	DIN standard 92 x 92 mm
Weight	approx. 650 g
Operating ambient temperature	-10 to +55 °C
Case sealing	IP22

INSTALLATION INFORMATION

Panel Mounting

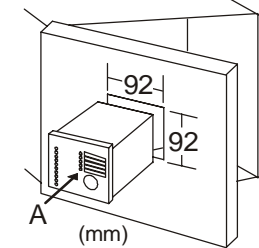

The AS705 is mounted in the front of a control panel through a DIN standard aperture, 92 mm (3⁵/₈" square.

With the mounting clamps removed, insert the unit through the front of the panel cut-out (A).

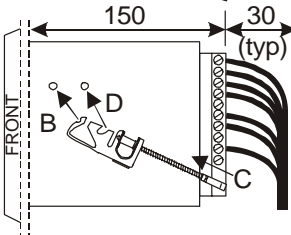

The case extends to 150mm (6") behind the panel front; a extra 30mm (1.25") minimum should typically be allowed for the connection of the wiring harness.

Working behind the panel front, fit both mounting clamps to pairs of studs on each side of the case. Locate the clamp on to the front stud (B), compress the clamp by pushing on the screw (C) and push the clamp upwards to locate on to the rear stud (D).

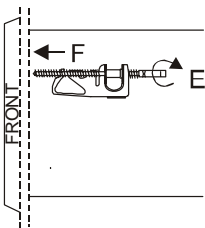

With both clamps fitted, tighten the screwed pins (E) so that they move forward and secure the unit to the rear of the panel facia (F). The case design allows for a panel thickness of up to 8mm.

Programming

The AS705 has over 50 programmable features, including settings for timers, trip levels, alarms and control options. These **MUST** be programmed correctly before the Autostart can be tested or used to control an engine.



WARNING: Failure to correctly program each unit can result in damage to Autostart, engine and other equipment.

The AS705 is programmed by connection to a PC running Murphy software model AS7CK. The communication link is made through the D-connector at the AS705 rear, and requires an RS232 interface unit and lead (supplied separately):-

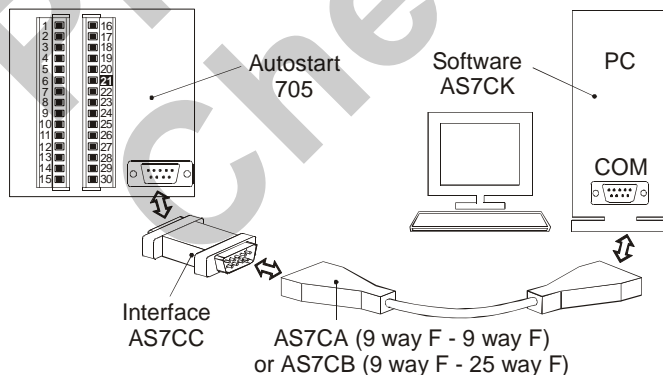

The software is used to create and edit program 'profiles', which can be downloaded to the Autostart over the communication link, quickly and error free.

Full information about communication links and PC software may be found in document mi5266. Detailed information about the AS705 program options can be found in document mi5265 (AS7xx programming reference).

Electrical Connection

General

Electrical connection is through a pair of terminal blocks at the rear of the unit: the two-part, screw terminals blocks are labelled 1 – 15 and 16 – 30. Use a 3mm (1/8") flat head screwdriver to loosen and tighten each screw terminal.

Before connection or disconnection, ensure that the unit is switched to O (off) and that all DC and AC power supplies are isolated.



WARNING: connection to or disconnection from live wiring can cause damage to internal components.

General wiring recommendations

Murphy make the following recommendations:-

Terminal blocks

- Ensure that no more than 2 wires are inserted into each screw terminal
- Ensure that terminal blocks are fully pushed home into Autostart rear facia receptacles.

External Slave Relays are a recommended connection on all outputs (as shown right), either to achieve the required load switching capability, or to reduce wear and tear on internal relay contacts.

Slave relay and solenoid coils will naturally emit voltage spikes when de-energising. Suppress this interference at source using the relay manufacturer's recommended suppression network. DC coiled relays can also be suppressed using a reversed biased flywheel diode as shown right.

Battery chargers

Some battery chargers feature significant ripple and switching noise on the DC output. This electrical interference can be imposed on the panel power supply and control lines, with the potential to cause faulty operation of (and in extreme cases damage to) electronic control equipment.

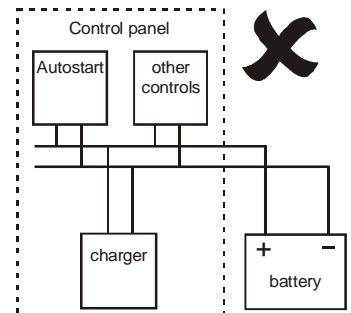
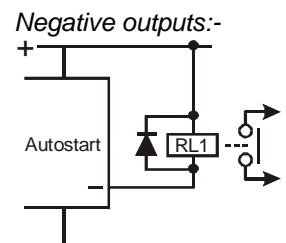
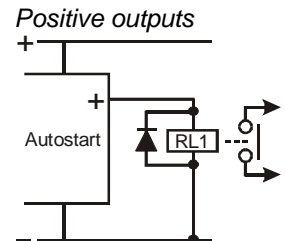

INSTALLATION INFORMATION (cont.)

Minimise the effects of charger output noise by using separate wiring 1) between charger output and battery terminals and 2) between battery terminals and panel DC supply rail.

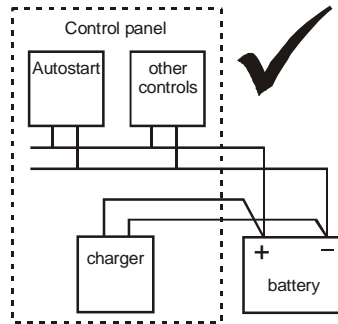

Terminal Functions

The functions of each connection are as follows:-

Terminal block 1 – 15

Pin Function

- 1 Negative DC power supply**
3 Positive DC power supply

Autostart will operate with any clean, noise-free supply in the range 5 to 40 V DC (normally the engine's 12V or 24V battery). Connect a 5 Amp anti-surge fuse in the positive DC line (pin 3). See also 'general wiring recommendations' above regarding battery chargers.

In normal operation, the AS705 measures the DC supply, and will flash the charge fail LED if the supply voltage falls out of programmed high and low limits.

2 Charge fail input

A 'charge fail' warning may occur if pin 2 is switched to negative DC. The following program options are available:-

- Charge 'alternator'. Connect pin 2 to the charge alternator warning lamp (WL) terminal – note that Autostart provides the necessary charge excitation current. The 'WL crank cut' program settings allows the option of an automatic crank release above a pre-set charge alternator voltage.
- 'Mains charger'. Connect pin 2 to the 'charge fail' output of a Murphy BC700 series charger, or direct to negative DC via relay contacts which close on fault.
- 'Not used' (or - -). Use this option if a charge fail alarm is not required, and leave pin 2 open circuit.

4 Positive DC (feed for relays)/Emergency stop

This positive DC connection provides a feed for the Fuel and Start outputs (pins 22 and 23). If required, emergency stop switches (push to break, mechanically latching types) may be wired between positive and pin 4: Autostart shuts down the engine and indicates 'emergency stop' if pin 4 is made open circuit.

5 Magnetic pickup

Allows the optional use of a magnetic pickup for sensing engine speed. Connect one pickup terminal to pin 5, the other terminal to pin 1 or battery negative. Use a two core and shield cable for interconnection, with the shield grounded at one end only.

Before use, the AS705 must be programmed with the correct number of flywheel teeth, and with correct trip levels (in engine RPM) for crank release, underspeed and overspeed.

- 6 Programmable output 1**
7 Programmable output 2
9 Programmable output 3
10 Programmable output 4

These outputs may be programmed to give a range of signalling and control 'actions', e.g. 'preheat', 'engine running', 'overspeed', etc. Please refer to programming literature mi5265 for full details.

Electrically, all 4 terminals give a negative DC output when active. Outputs 1 to 3 are open collector transistor types, rated to a maximum current of 300mA. Output 4 is relay based, giving a switched negative output of up to 5 Amps.

The connection of slave relays is recommended, as detailed above in 'general wiring recommendations'.

8 A800 enable output

Pin 8 may be used to give a 'seam free' operation with the Murphy A800 alarm/annunciator unit. The output may be connected directly to the A800 enable input: the A800 fault/warning inputs are only then enabled once the Autostart detects that the engine is running.

No attempt should be made to connect pin 8 to anything other than an A800 enable circuit.

11 Remote start/mains fail input

Use this input to initiate an automatic engine start in AUTO mode. Pin 11 must be switched to positive DC when the engine is required to be on standby, and made open circuit to initiate an automatic start.

12 No connection

13 Off/reset output

Gives a negative DC output (250mA max.) when the unit is switched to \bigcirc (off/reset).

14 Manual mode output

15 Auto mode output

Each of these terminals gives a positive DC output (250mA max) when Autostart is respectively switched to manual or auto modes.

Terminal block 16 – 30

16 Input 1: (low) oil pressure (LOP)

17 Input 2: (high) engine temperature (HET)

Input pins 16 and 17 are dedicated for use with low oil pressure and high engine temperature fault switches. The inputs may be programmed for use with either 'open on fault' or 'closed on fault' contacts, and for contacts wired between the input and battery positive or negative. In normal operation, an active input causes an immediate engine shutdown.

The oil pressure input is also checked by Autostart before cranking the engine, and MUST therefore be connected to ensure correct operation. If a high oil pressure is detected, Autostart inhibits cranking and lights the 'plant fail' LED.

INSTALLATION INFORMATION (cont.)

- 18 Input 3 (programmable)**
- 19 Input 4 (programmable)**
- 20 Input 5 (programmable)**

These inputs may be used with switch contacts to trigger a range of programmable 'actions', e.g. shutdown fault, warning fault, lamp test, manual restore (of mains), etc. Full details of program 'actions' can be found in document mi5265.

Connect the switch contact between each input and battery positive or negative, and program each input to activate as required (open/closed/positive/negative).

21 Index pin (no connection)

22 Fuel output

23 Starter output

These are positive DC outputs, rated to 16 Amps, for the control of engine fuel and starter motor circuits. Connection of slave relays is recommended, as detailed above in 'general wiring recommendations'.

24 Programmable output 5

(default setting: 'common alarm')

Pin 24 is a positive DC relay output, rated to 5 Amps. With its default 'common alarm' setting, the output activates during any fault (warning or shutdown). The output can, however, be programmed to give other 'actions', as for inputs 1 to 4.

25 Programmable output 6 (Normally Open contact)

26 Programmable output 6 (Change-over contact)

(default setting: 'gen. contactor')

Output 6 is a volt-free set of normally open relay contacts, which can be programmed with the same range of 'actions' as outputs 1 to 5.

With its default 'gen. contactor' action, the output is typically used to control a generator contactor coil

circuit. The output will activate (contacts close) when:-

- a) generator voltage is above 66% of nominal (non-programmable)
- b) generator frequency/speed is above the programmed trip level
- c) oil pressure is OK, and
- d) after the 'warm-up' delay time has expired.



These terminals may be wired as above to panel push-buttons, allowing operator control of engine starting and stopping when the unit is switched to 'manual' mode. Alternatively, hard-wire pins 27 and 28 to battery negative to give an immediate engine start on switching to manual mode.

29 Generator Live

30 Generator Neutral

For generator applications, connect these terminals to generator AC (50/60Hz). Line to neutral or line to line connections may be used, so long as the voltage does not exceed 300VAC. Connect a 1 Amp anti-surge fuse in series with the generator live terminal (pin 29).

Autostart uses these terminals to sense the generator voltage, and also its frequency when a magnetic pickup is not used. Correct voltage and frequency is needed to ensure the operation of a 'generator contactor' output. Frequency alone may be used to trigger the automatic crank release and overspeed trip.

For non-generator applications (e.g. a diesel pump), leave these terminals open circuit and ensure that the 'AC sense' setting is programmed to 'no'. Speed sensing must then be made using a magnetic pickup (see pin 5).

TYPICAL CONNECTION (mains fail generator application)

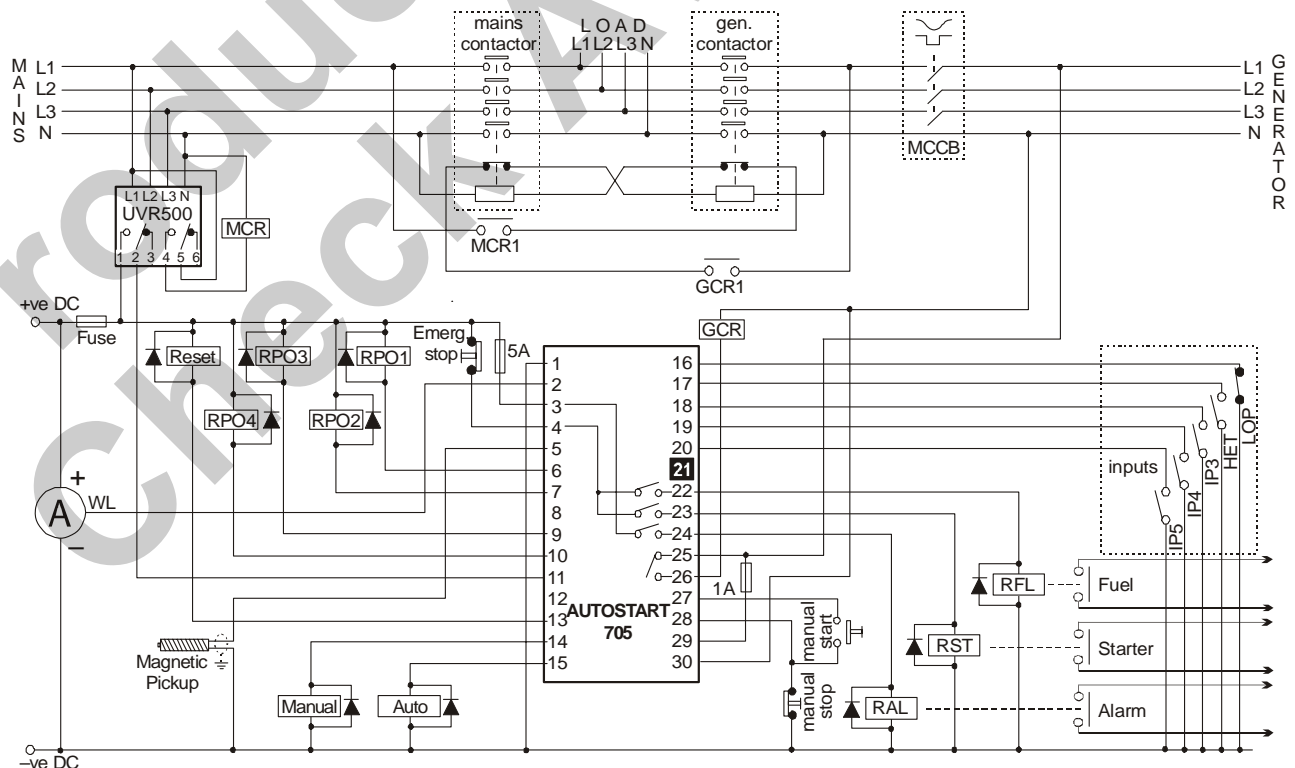

INSTALLATION INFORMATION (cont.)

Custom labelling

The top right of the front facia features 5 LEDs (2 amber, 3 red), each of which may be programmed to customer requirements. Approximately 40 functions are available, e.g. fuel on, generator on load, etc. - for a full lists of functions, please refer to programming reference mi5265.

Next to these LEDs, the front label contains a pocket with clear windows, into which an appropriate custom message label can be inserted. Custom labelling is carried out as follows:-

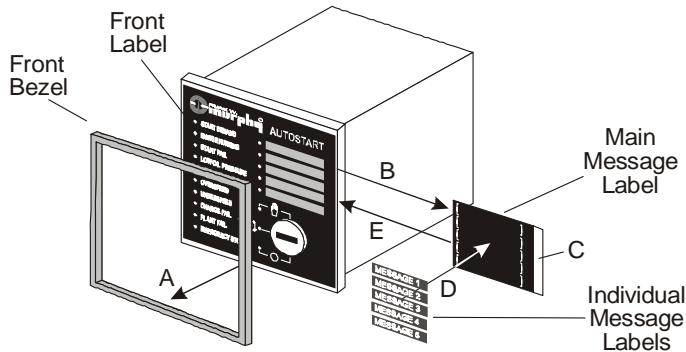

- 1 Remove the front facia bezel (A) by unsnapping each of the four corners in turn.
- 2 Remove any existing label (B) by pulling on the label tab (C).
- 3 Prepare a new custom label. A sheet provided with each unit includes individual messages for common status and fault conditions. Cut out the text messages as appropriate, remove the adhesive backing, and fix the messages in the spaces provided on the 'main message label' (also supplied on each sheet).
Alternatively, custom labels may be designed and printed using Microsoft Excel spreadsheet file **AS705 custom label.xls**, which is supplied with programming software AS7CK.
- 4 Insert the completed label into the AS705 front label pocket. Ensure the label is correctly aligned, then snap on the front bezel.

Note: the 10 LEDs on the left of the front facia are also programmable (LEDs A – J in the programming software), but are preset in terms of the standard front facia label. Labels to custom design are however available in bulk quantities – please contact your Murphy representative for full details.

Warranty and Maintenance

This unit is supplied with a 2 year warranty on parts and workmanship. Details are available on request and are supplied with each unit.

The AS705 contains no user-serviceable parts. Maintenance is therefore limited to the following preventative checks:-

- Check that the rear terminal blocks are pushed home fully, and that the wiring to screw terminals is secure.
- Check that the Autostart is securely clamped in the front of panel aperture, and kept free from ingress of water or build up of excessive dust/dirt. The front facia label and casing may be wiped with a clean, damp cloth. **Do not** use cleaning solvents.

The keys of all AS705 units are generally interchangeable, but note that the key type changed in Jan. 2001. The keys, fixing clamps, terminal blocks are available as spare components, as are the range of communication accessories:-

Stock code	Model ref	Description
76.70.0096	AS3/KEYB	1 pair of keys (L&F93201), for units Dec 2000 or earlier ('V' serial number or earlier)
76.70.0304	AS7/KEYC	1 pair of keys (L&F85000), for units Jan 2001 or later ('W' serial number or later)
76.70.0124	KEY/CLAMPS	1 pair of mounting clamps
76.70.0121	AS7TBA	Terminal block 1-15
76.70.0122	AS7TBB	Terminal block 16-30
76.70.0018	AS7CA	Comms lead (null modem), 9 way (interface) to 9 way (PC)
76.70.0019	AS7CB	Comms lead (null modem), 9 way (interface) to 25 way (PC)
76.70.0020	AS7CC	Interface, Autostart to RS232 local communication
76.70.0203	AS7CK	PC software for AS7xx communication and programming (also available free of charge from the 'Downloads' section of www.fwmurphy.co.uk)

In the event of a fault or technical query, please contact your Murphy representative for technical support. Technical documents are also available from the Products sections of our web-site www.fwmurphy.co.uk

FW MURPHY

P.O. Box 470248, Tulsa, Oklahoma 74147 USA
+1 918 317 4100 Fax +1 918 317 4266
E-mail: sales@fwmurphy.com

INDUSTRIAL PANEL DIVISION

Fax +1 918 317 4124
E-mail: ipdsales@fwmurphy.com

MURPHY POWER IGNITION

Website: www.murphy-pi.com

CONTROL SYSTEMS AND SERVICES DIVISION

P.O. Box 1819, Rosenberg, Texas 77471 USA
Phone: +1 281 633 4500 Fax: +1 281 633 4588
E-mail: css-solutions@fwmurphy.com

FRANK W. MURPHY LTD.

Church Road, Laverstock,
Salisbury, SP1 1QZ, United Kingdom
Tel: +44 1722 410055
Fax: +44 1722 410088
E-mail: sales@fwmurphy.co.uk
Web: www.fwmurphy.co.uk

COMPUTRONIC CONTROLS

41 - 46 Railway Terrace, Nechells,
Birmingham, B7 5NG, United Kingdom
Tel: +44 121 327 8500
Fax: +44 121 327 8501
E-mail: sales@computroniccontrols.com
Web: www.computroniccontrols.com

FW MURPHY INSTRUMENTS (HANGZHOU) CO., LTD.

77 23rd Street, Hangzhou Economic & Technological Development Area
Hangzhou, Zhejiang, 310018, China
Phone: +86 571 8788 6060 Fax +86 571 8684 8878
E-mail: apsales@fwmurphy.com



USA-ISO 9001:2000 FM 28221
UK-ISO 9001:2000 FM 29422
Registered Facilities

