

## WD100/WD270 series Engine and Pump Protection Panels



### Features

- Engine and pump protection for mobile or stationary applications
- Switchgauge indication and automatic shutdown of mechanical (non-ECU) engines
- Instant shutdown or warning before shutdown
- Compact and easy to install

WD100 and WD270 series panels are a rugged, dependable solution for mechanical (non-ECU) engine or pump fault monitoring and protection. Their compact size and ease of installation make these panels highly suited to mobile or stationary engine-driven applications such as tractors, PTO devices, earth moving equipment and pumps.

WD series panels use the accurate and reliable Murphy Switchgauge® for indication and fault shutdown. All WD panels feature Switchgages for oil pressure (0 - 100psi / 0 – 7 bar) and coolant temperature (50 – 120°C). Options are also available for indication/shutdown of pump water pressure (0 – 20 Bar), oil temperature (60 – 140°C) and auxiliary contact shutdown: see 'how to order' overleaf for a full feature reference.

Each panel uses a robust steel, black painted enclosure, fitted with a rotating bracket for ease of installation and use. Mobile equipment warning-before-shutdown versions (WD277) also feature Murphy Selectronic® TL7 flashing alarm light and SAH mini-siren, both of which activate on fault, 30 seconds before an automatic shutdown.

Standard panels are supplied complete with a 2 metre oil line and adaptors, 3 crimped wires for electrical connection (battery positive, battery negative and fuel/shutdown output) and a wiring diagram. The WD series is designed for use on 12VDC engines with energised-to-run type fuel solenoids.

### Dimensions

#### WD100

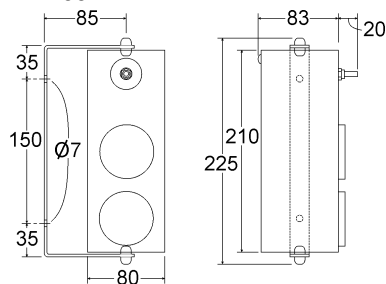

Panel/Switchgauge® orientation:-  
- vertical in WD100

#### WD270/WD277

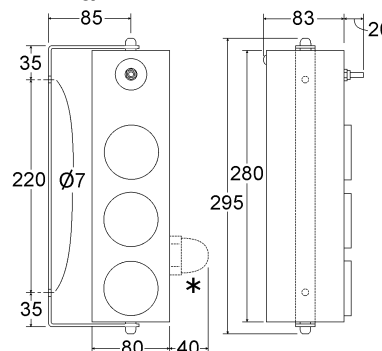

\* TL7 flashing alarm on WD277 only.

Panel/Switchgauge® orientation:-  
- vertical in WD270  
- horizontal in WD277

## Operation

### WD100

#### General engine protection, instant fault shutdown

While starting the engine, hold in the 518APH reset button until the engine starts and the Swichgage® low oil pressure contact clears.

As soon as a low oil pressure or high coolant temperature fault occurs, the WD100 will immediately shut down the engine. Rectify the fault causing shutdown, then resume operation.

### WD270

#### Pump applications, instant fault shutdown

##### Starting

*Method 1:* hold in the 518APH reset button then start the engine as normal. The reset button may be released when both engine oil pressure and pump pressure have increased above the Swichgages' low limit set points.

*Method 2:* Before engine starting, temporarily set the low water pressure Swichgage® contact to minimum (so that the contact is open circuit). Press and hold the 518APH reset button during engine starting, then release the reset button once the engine starts and the Swichgage® low oil pressure contact clears. Monitor the pump water pressure until it rises above the low pressure shutdown level, then raise the Swichgage® contact to this low pressure limit.

##### Running / fault shutdown

As soon as an engine pressure/temperature or pump pressure fault occurs, the WD270 will immediately shut down the engine. Rectify the fault causing shutdown, then resume operation.

### WD277

#### Mobile applications, warning before shutdown, auto override of low pump pressure on startup

Start the engine in the normal manner. The red light (TL7) will flash and the Mini-Siren® will sound until the engine starts and lifts the Swichgage® low oil pressure contact.

If the red light comes on or the Mini-Siren® sounds during normal driving it is a warning to shut down the engine as quickly as possible. Otherwise, the panel will shut down the engine automatically within 30 seconds.

After an automatic shutdown, the engine may be restarted in the normal way, but will only run for 30 seconds.

Once the vehicle has been safely stopped, rectify the engine fault then resume normal operation.

## How to order

Please select the stock number below based on the features required:

Stock number	Panel type	Supply volts (VDC)	Magnetic shutdown switch	20P oil pressure Swichgage® (0 - 100psi / 0 - 7 bar)	Oil line, 2m	20T coolant temperature Swichgage® (50 - 120°C) with 2m capillary	20T oil temperature Swichgage® (60 - 140°C) with 2m capillary	Socket & jackplug auxiliary shutdown input	Manual lockout of engine fault on startup	Automatic lockout of engine fault on startup	High/low pump pressure Swichgage® (0 - 20 Bar) with 3m utility line	Manual lockout of low pump pressure on startup	Adjustable 0 - 15 minute lockout of low pump pressure on startup	Instant fault shutdown	Warning before shutdown (flashing lamp and mini-siren)
B2644	WD100	12	✓	✓	✓	✓	✗	✓	✓	✗	✗	n/a	n/a	✓	✗
B2842	WD270	12	✓	✓	✓	✓	✗	✗	✓	✗	✓	✓	✗	✓	✗
B6300	WD277	12	✓	✓	✓	✓	✓	✗	✗	✓	✗	n/a	n/a	✗	✓

**ENOVATION CONTROLS CORPORATE HEADQUARTERS**  
5311 S 122ND EAST AVENUE, TULSA, OK 74146, USA

**ENOVATION CONTROLS - SAN ANTONIO OFFICE**  
5757 FARINON DRIVE, SAN ANTONIO, TX 78249, USA

**ENOVATION CONTROLS -HOUSTON OFFICE**  
105 RANDON DYER RD, ROSENBERG, TX 77471, USA

**ENOVATION CONTROLS LTD. - UNITED KINGDOM**  
CHURCH ROAD, LAVERSTOCK, SALISBURY, SP1 1GZ, UK

**MURPHY ECONTROLS TECHNOLOGIES - CHINA**  
77 23RD STREET, HANGZHOU ECONOMIC & TECHNOLOGICAL DEVELOPMENT AREA, HANGZHOU, ZHEJIANG 310018 CHINA

#### SALES & SUPPORT, NORTH AMERICA

**MURPHY PRODUCTS:**  
PHONE: 918 317 4100  
FAX: 918 317 4266  
EMAIL: SALES@FWMURPHY.COM  
WWW.FWMURPHY.COM

**ECONTROLS PRODUCTS:**  
PHONE: 210 495 9772  
FAX: 210 495 9791  
EMAIL: INFO@ECONTROLS.COM  
WWW.ECONTROLS.COM

**MURPHY CONTROL SYSTEMS & SERVICES**  
PHONE: 281 633 4500  
FAX: 281 633 4588  
EMAIL: CSS-SOLUTIONS@FWMURPHY.COM

**MURPHY INDUSTRIAL PANEL DIVISION**  
PHONE: 918 317 4100  
FAX: 918 317 4124  
EMAIL: IPDSALES@FWMURPHY.COM

#### SALES & SUPPORT, INTERNATIONAL

**EUROPE, MIDDLE EAST & AFRICA**  
PHONE: +44 1722 410055  
FAX: +44 1722 410088  
EMAIL: SALES@ENOVATIONCONTROLS.EU  
WWW.FWMURPHY.EU

**CHINA**  
PHONE: +86 571 8788 6060  
FAX: +86 571 8684 8878  
EMAIL: APSALES@FWMURPHY.COM

**LATIN AMERICA & CARIBBEAN**  
PHONE: +1 918 317 2500  
EMAIL: LASALES@FWMURPHY.COM

**SOUTH KOREA**  
PHONE: +82 70 7951 4100  
EMAIL: SKOREASALES@FWMURPHY.COM

**INDIA**  
PHONE: +91 91581 37633  
EMAIL: INDIASALES@FWMURPHY.COM

**ISO 9001**  
REGISTERED



USA: ISO9001:2008 FM28221  
UK: ISO9001:2008 FM29422  
CHINA: ISO9001:2008 FM52382