

Installation Instructions - Level Switchgag[®] Instruments for Engine Liquids – Models L150, EL150K1, and EL150EX



Applications

The primary use of these level Switchgag instruments is for engine cooling systems, surge or expansion tanks, condenser radiator or vapor phase systems, whether pressurized or atmospheric. These instruments can also be used to monitor lube oil, hydraulic fluid or diesel fuel reservoirs and activate alarms and/or shutdown at a predetermined minimum level. These instruments are built for low pressure systems.

COLD WEATHER WARNING

BEFORE FREEZING WEATHER COMES, CHECK TO BE SURE YOUR L150 OR EL150 SERIES, COOLANT LEVEL SWITCHGAGE IS FILLED WITH ANTIFREEZE SOLUTION THE SAME AS YOUR ENGINE BLOCK AND RADIATOR.

On many engines, such as condenser radiator systems, the coolant in your level Switchgag remains static until the level falls to drain point. When 'winterizing' it is a good idea to make certain all water drains from your level Switchgag, to check against clogged connections, and then BE SURE IT REFILLS WITH ANTIFREEZE. FAILURE TO OBSERVE THIS PRECAUTION COULD RESULT IN EQUIPMENT DAMAGE.



BEFORE BEGINNING INSTALLATION OF THIS MURPHY PRODUCT READ AND FOLLOW ALL INSTALLATION INSTRUCTIONS.

- A visual inspection of this product for damage during shipping is recommended before mounting.
- It is your responsibility to have a qualified person install this unit and make sure it conforms to NEC and local codes.
- Disconnect all electrical power to the machine.
- Make sure the machine cannot operate during installation.
- Follow all safety warnings of the machine manufacturer.
- Please contact Enovation Controls immediately if you have any questions.

CAUTION: Certain danger to human and to equipment such as applied in a mobile or marine application may occur if some equipment is stopped without pre-warning. It is therefore recommended that monitored functions be limited to alarm only or to alarm before shutdown in such applications.

In order to consistently bring you the highest quality, full-featured products, we reserve the right to change our specifications and designs at any time. MURPHY products and the Murphy logo are registered and/or common law trademarks of Enovation Controls, LLC. This document, including textual matter and illustrations, is copyright protected by Enovation Controls, LLC, with all rights reserved. (c) 2017 Enovation Controls, LLC. A copy of the warranty may be viewed or printed by going to www.murphybyenovationcontrols.com/warranty

ENOVATION CONTROLS CORPORATE HEADQUARTERS
5311 S 122ND EAST AVENUE
TULSA, OK 74146

ENOVATION CONTROLS LTD. – UNITED KINGDOM
CHURCH ROAD LAVERSTOCK
SALISBURY SP1 1QZ UK

MURPHY INTERNATIONAL TRADING – CHINA
SUITE 1704, ANTAI BUILDING, 107 ZUNYI RD
SHANGHAI, 2000 S1 CHINA

ENOVATION CONTROLS INDIA PVT. LTD.
301, 3RD FLOOR, KRSNA CHAMBERS,
11 GALAXY GARDENS, NORTH MAIN ROAD,
KOREGAON PARK, PUNE 411001,
MAHARASHTRA, INDIA

U.S. SALES & SUPPORT

MURPHY PRODUCTS
PHONE: 918 317 4100
EMAIL: SALES@ENOVATIONCONTROLS.COM
WWW.ENOVATIONCONTROLS.COM

MURPHY INDUSTRIAL PANEL DIVISION
PHONE: 918 317 4100
EMAIL: IPDSALES@ENOVATIONCONTROLS.COM

INTERNATIONAL SALES & SUPPORT

EUROPE, MIDDLE EAST, AFRICA
PHONE: +44 1722 410055
EMAIL: SALES@ENOVATIONCONTROLS.EU

CHINA
PHONE: +86 21 6237 5885
EMAIL: APSALES@ENOVATIONCONTROLS.COM

LATIN AMERICA & CARIBBEAN
PHONE: +1 918 317 2500
EMAIL: LASALES@ENOVATIONCONTROLS.COM

INDIA
PHONE: +91 91581 37633
EMAIL: INDIASALES@ENOVATIONCONTROLS.COM



FM 28221 (Tulsa, OK - USA)
FM 29422 (UK)

Dimensions

L150

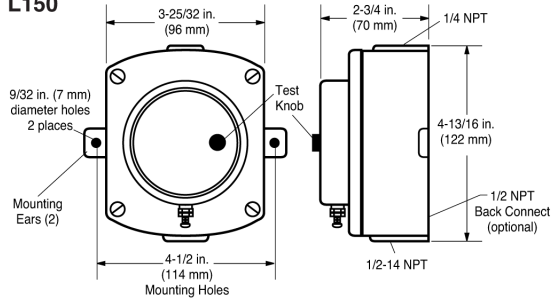

EL150K1

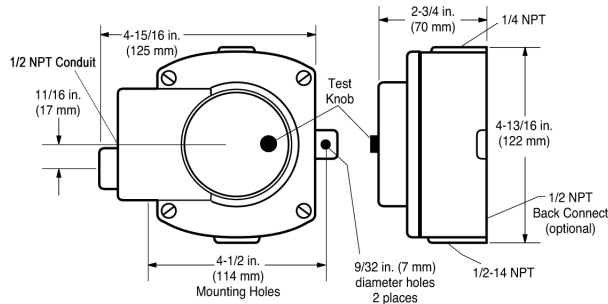

EL150EX

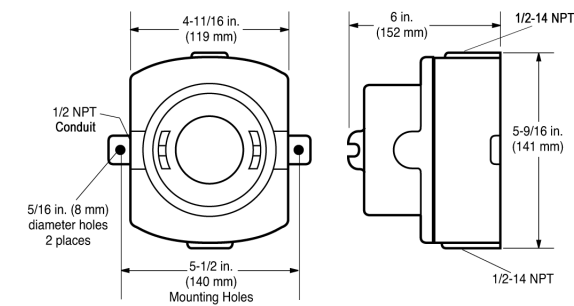

Installation Instructions

PS Fittings Installation

A Murphy PS fitting is used when there is no threaded fitting in the top tank of the radiator to attach tubing for the L150/EL150 series level Swichgage instrument.

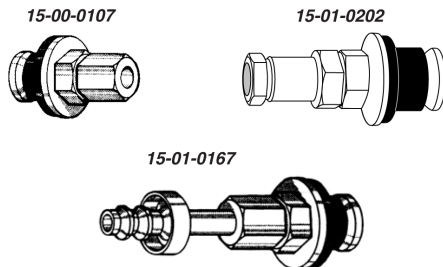

- **P/N 15-00-0107 (PS)** Accepts 1/4 in. (6mm) O.D. copper tubing.
- **P/N 15-01-0167 (PS Barbed)** Barbed fitting accepts 1/4 in. (6mm) I.D. flexible tubing and hose clamp.
- **P/N 15-01-0202 (PS-D)** Accepts 1/2 in. (13mm) I.D. hose; 1/4 in. (6mm) copper tube.

1. Determine the entry point into the radiator top tank. See **Level Swichgage Instrument Installation** for proper location. Drill 1/8 in. (16mm) diameter hole in top tank of radiator. Be sure chips do not fall inside the tank. Remove any burrs on the hole wall.
2. Insert the rubber grommet of the PS Fitting. Tighten the jam nut while holding the fitting from turning in the hole. The jam nut will pull the tapered grommet into the hole from the inside of the top tank causing the grommet to expand and seal the hole.
3. Attach the appropriate tubing or hose for the PS Fitting.

Level Swichgage Instrument Installation

WARNING: Perform all installations with the power source "OFF". Be sure engine and radiator have cooled and coolant pressure has been relieved. SEVERE BURNS can result. Never remove a radiator cap from a hot engine.

IMPORTANT: Operation of the L150/EL150K1 is different for a pressurized cooling system than for an atmospheric (non-pressurized system.) Installation of the L150/EL150K1 is only slightly different for each system. Connection of the top tube connection is the major difference. Differences will be noted in the installation instructions.

Installation Notes

1. All top radiator connections must be away from the return hose turbulence.
2. All bottom radiator connections must be away from the suction hose.
3. If top tank and bottom tank entries are used on a pressurized system, a restriction in the tubing will have to be added to prevent flow through the L150/EL150K1, bypassing the core. Examples of restriction: 1/4" upper tubing, 1/8" lower tubing, needle valve, or fixed small orifice.
4. The L150/EL150K1 must be attached to a mounting plate on the radiator or other framework.

CAUTION: If the L150/EL150K1 is NOT attached to the radiator, use high temperature quality flexible hose for the top and bottom connections to maintain the shock mounting protection for the radiator.

Pressurized and Atmospheric Systems

1. Drain the cooling system.
2. For a **Pressurized System** (see Figure 1) determine the point of entry (tube connection) in the radiator top tank (away from the top hose connection). Many radiators have a pipe nipple provided. If a connection is not provided, you must either weld or solder a fitting or use one of the Murphy PS fittings. See **PS Fittings Installation**. This connection should be as close to the radiator core as possible.

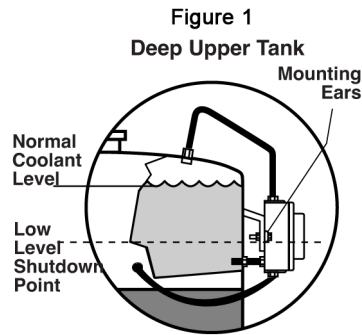

NOTE: Both back-connected and bottom-connected shown.

For **MARINE AND MOBILE EQUIPMENT** installations, the top tank connection should be near the vertical centerline of the radiator. This will compensate for changing level due to roll and pitch of the machine during operation.

3. For an **ATMOSPHERIC SYSTEM** a tube connection in the top tank may not be required. Determine the lowest desired level of coolant in the top tank. Mount the L150/EL150K1 so that the mounting ears are approximately 1/4 in (6mm) above that level (see Figure 2).

A back mounting option is available for the L150 and EL150K1 for radiators with fabricated steel top tank and/or for use with some condenser cooling systems.

Figure 2

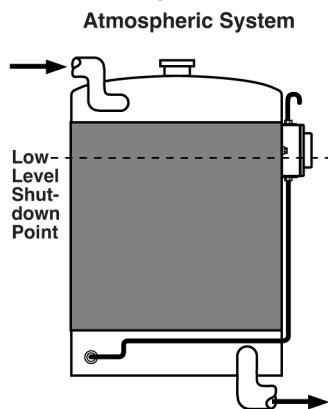

Install a 1/4 in. (6mm) diameter tube in the top fitting of the L150/EL150K1. This tube **MUST EXTEND ABOVE** the top tank. Form the tube into a cane so that the open end of the tube points down but still extends **ABOVE** the **HIGHEST** coolant level. The tube can be connected to the top tank if desired. Follow instructions for a **PRESSURIZED SYSTEM**.

4. For most applications, the bottom tube connection is made at the drain cock. Remove the drain cock and install a brass tee. Reinstall the drain cock into the tee. Attach a copper or other suitable tube to the remaining opening of the tee and to the bottom connection of the L150/EL150K1.

If a drain cock is not provided, you must attach a fitting or use a Murphy PS fitting the same as for the top tank instructions.

5. Wire according to appropriate alarm or shutdown circuits (See **Standard Electrical Diagrams**).
6. Refill the cooling system according to manufacturer's instructions.
7. Start the engine and allow it to run until the thermostat opens. Increase engine speed to the FULL operating speed and observe that the indicating pointer remains at or near the full position. If the pointer drops to the LOW position, shutdown or alarm will occur due to coolant flow through the L150/EL150K1. If alarm or shutdown occurs, drain the coolant – or clamp off the upper and lower hoses.

CAUTION: SYSTEM UNDER PRESSURE – COOLANT IS HOT – SEVERE BURNS MAY RESULT.

8. **CAUTION:** BE SURE SYSTEM PRESSURE IS RELIEVED AND HOT COOLANT CANNOT ESCAPE.

Remove the four (4) mounting screws holding the cover assembly. Invert the float chamber so that the 1/2 NPT connection is on top and the 1/4 NPT connection is on bottom. Reinstall the float and cover assembly in the upright position. Install larger I.D. tubing from the top of the float chamber (1/2 NPT-use 1/4" tube) to the radiator top tank. The smaller 1/4 NPT (may need to try 1/8" tube) connection on the bottom will restrict coolant outflow from the L150/EL150K1. Check for unrestricted float movement by rotating the switch test knob.

Refill the cooling system and repeat step 7.

CAUTION: DO NOT ALLOW ENGINE TO RUN WHEN COOLANT DRAINS BELOW THE UPPER TANK. ENGINE DAMAGE CAN OCCUR.

9. Periodically test switch operation by rotating the test knob on the face of the L150/EL150K1. Rotating the knob forces the pointer mechanism against the contact screw (L150) or the snap switch actuator (EL150K1).

Condensor/Radiator System

1. Mount the L150/EL150K1 so that the horizontal center line of the L150/EL150K1 is approximately 1/4 in. (6 mm) above the minimum coolant level in the engine head.

NOTE: on some engines it is possible to use the back connection option and attach the L150/EL150K1 directly to the engine cylinder. Kits are also available for some engines.

2. Attach a copper tube from the top connection of the L150/EL150K1 to the radiator top tank.
3. Wire and test the system according to the above instructions for Pressurized and Atmospheric systems.

Standard Electrical Diagrams

WARNING: Perform all installations with the power source "OFF".

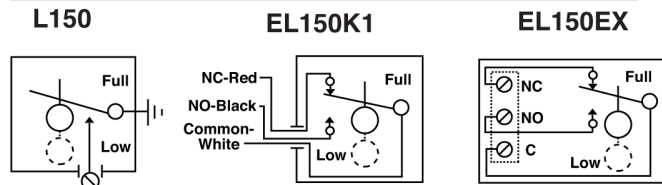

NOTE: All models shown with pointer in full position.

EL150EX-D

WIRING DIAGRAM-DPDT

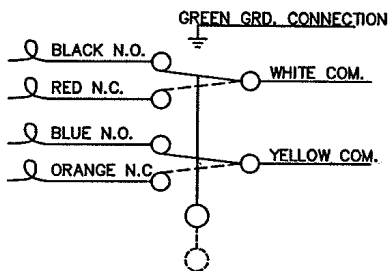

Repair Kits

Repair kits are available for the L150, EL150K1 and EL150EX models. When ordering a repair kit, specify model repair kit number from chart below:

Model	Components	Repair Kit No.
L150		15-00-0138
	Case//body assembly	15-00-0101
EL150K1	All parts except case/body	15-00-0139
	Lens and switch assembly	15-00-0100
	Case/body assembly	15-00-0101
EL150EX	Cover and float assembly	15-00-0110
	Lid assembly	15-00-0108
	Switch/Terminal assembly	15-00-0109

Replacing the Float and Cover Assembly for the L150 and EL150K1

WARNING: Perform the following operation with the power source "OFF". Be sure engine and radiator have cooled and coolant pressure has been relieved. SEVERE BURNS can result. Never remove radiator cap on a hot engine.

1. As applicable, shut off liquid to the Swichgag instrument or drain the system level below the Swichgag instrument.
2. Disconnect electrical lead(s), one at a time, and tag for reinstallation.
3. Disconnect conduit on EL150K1.
4. Remove the four screws that secure the float and glass assembly to the case.
5. Remove and discard the old float and cover assembly.
6. Remove and discard the old gasket.
7. Install the new gasket.
8. Install the new float and cover assembly and secure it with four screws.
9. Re-connect the conduit on EL150K1.
10. Reconnect the electrical lead(s).
11. As applicable, open valves to the Swichgag instrument or refill the system to proper level.
12. Check the Swichgag instrument for proper operation at the full indicating position. (Alarm not operated/engine continues to operate.)
13. Check the Swichgag instrument, alarm/shutdown circuit, by rotating the test knob toward the low level point of the dial; alarm is operated/engine shuts down.
14. Check for unrestricted float movement by rotating the switch test knob.
15. Replacement of the float and cover assembly is complete.

WARNING: On some high voltage CD ignition systems, it may be necessary to coat the L150 contact screw head with RTV to prevent "tracking" and false contact operation during wet or high humidity conditions. Use of the EL150K1 is recommended in these cases.