

MOUNTING HOLE PATTERN

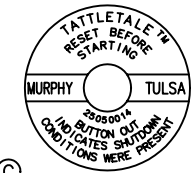
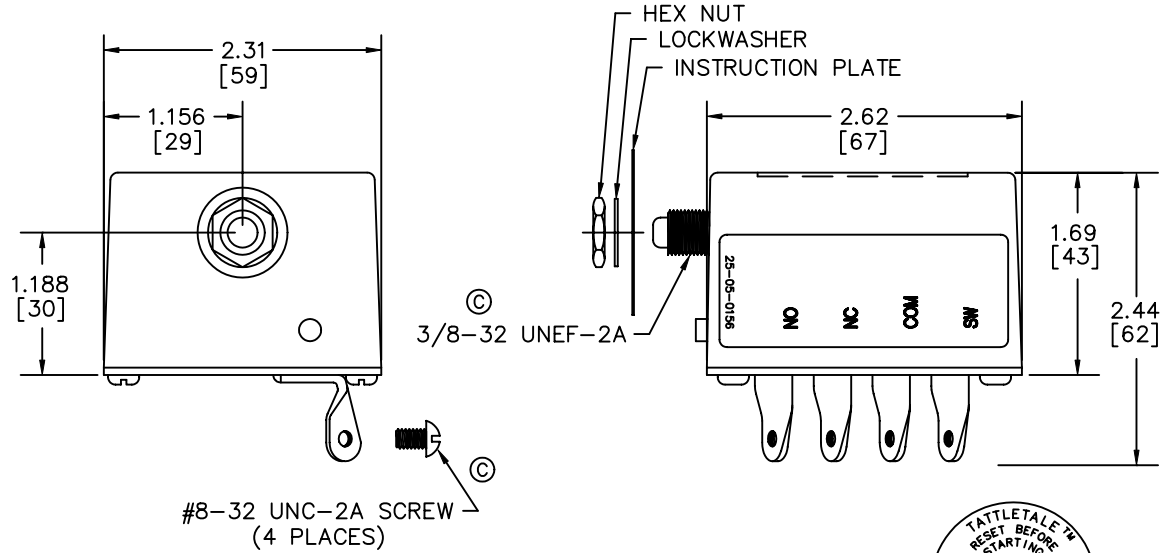
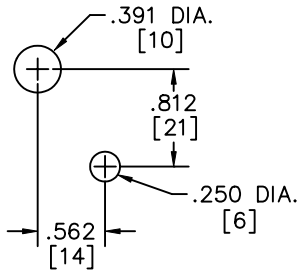

INSTRUCTION PLATE

SPECIFICATIONS:

- BASE: SYNTHANE
- CASE: POLYCARBONATE
- CONTACT RATING: 10 AMPS
- COIL RATING:
- COIL RESISTANCE: 30 ohms ± 10%
- MINIMUM TRIP VOLTAGE: 8 VDC
- MINIMUM TRIP CURRENT: 275 mA
- OPERATING TEMPERATURE RANGE: -40 TO 176°F (-40 TO 80°C)

TYPICAL WIRING

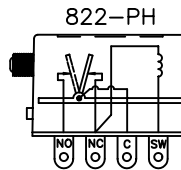

NOTES:

1. ALL DIMENSIONS IN [] ARE MILLIMETERS.

C	ADD 8-32 SCREW & 3/8-32, UPDATE INSTRUCTION		
	PLATE	(4-13-93) LB (ER# 93-0626) RJ	
REV.	CHANGES MADE		
DRAWN BY:	CINDY KERN	E.R.NO.	NONE
DATE:	5-30-79	CHKD. BY:	DDR APPD. BY: VB
MODEL:	822-PH		
DRAWING NO.	25-02-0046	SIZE	REV.
		B	C