

emc-1P & emc-1V

e-Fan Drive - System Controller User Guide

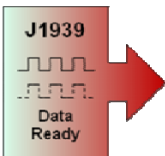

High Country Tek, Inc. reserves the right to improve this product at any time and without notice. This manual may contain mistakes and printing errors. The information in this publication is regularly checked and corrections made in the next issue. Please check our website or contact our customer support for latest version. HCT accepts NO liability for technical mistakes or printing errors or their consequences.



e-Fan Cooling System Controllers with J1939 Interface

High Country Tek, Inc. (HCT) is North America's foremost independent designer and producer of modular, ruggedized digital and analog electronic controller products for the fluid power industry.

From our factory in California, we build, test and produce 'specialty' controllers that provide solutions for specific everyday functions as well as our 'DVC family' of fully adaptable user programmable units that can be integrated together to enable large area networked system solutions.

The modules are typically used in mobile, industrial and marine applications, but are also applied successfully in several other growing global market segments.

Because High Country Tek has an industry unique non-repairable product protection system, with every module encapsulated in solid flame resistant material for maximum durability, electrical integrity and complete environmental security, we have to deliberately select the highest quality components from our suppliers at all times, ensuring our 100% operating shipped product.

HCT is also a market leader in many application arenas, including hydraulic generator, *e-Fan* and hydraulic fan system controls where significant fuel, emission and operational savings can be realized by using one of the aforementioned specialty units to optimize the applications operation.

HCT's market neutrality and flexible product configuration approach offers dependable integration with virtually any hydraulic OEM products for easy, simple and accurate control of valves, pumps, sub-systems or systems.

Our best-in-class customer service and product reliability is well known and trusted throughout the fluid power network and we look forward to working with you in the future.

www.Hctcontrols.com

*The information in this publication is intended as a guide only, and **High Country Tek, Inc. (HCT)** takes NO responsibility for usage and implementation in any user entered values into the provided GUI structure.*

HCT strongly suggests that the user attends one of the product training courses to ensure correct and full understanding of this information and to learn further optimized methods of control techniques.

Please contact HCT customer service to book one of the scheduled training dates or to discuss arranging a course specific to your company needs.

Thank you for using High Country Tek Inc. Products.



Table of Contents

Welcome	4
Introduction	4
Cautions	4
Warranty Information	4
Controller Updates:	4
'emc-1P & emc-1V' e-Fan System Controller	5
Product Overview	6
Product Application Guidelines	7
Software Safety	7
emc-1P & emc-1v Electrical Specification Overview	8
emc-1P Module Familiarity	9
emc-1P Connection Information	10
emc-1V Module Familiarity	11
emc-1V Connection Information	12
Error LED Code Descriptions for emc-1P & emc-1V	13
Module Connection Descriptions	14
Serial Communications	16
Loading the emc-1P or emc-1V GUI onto Host PC	17
System Requirements	17
Controller adjustments and Monitor	18
GUI Menu Options.....	18
Password Protection.....	19
Help.....	20
GUI software – Main screen (Dashboard).....	21
Data Logging.....	22
General Settings.....	23
Unit Settings.....	23
Output Settings.....	24
Auto Reverse Settings.....	24
Input Settings.....	25
Error Information Log.....	27
Factory Information.....	28
Temperature Sensor Information	29
Main I/O connector & Accessories	29
On Site Testing	30
emc-1P & emc-1V Dimensional Information	32
RS232 Communication Cable	33



e-Fan Cooling System Controllers with J1939 Interface

Welcome

Welcome to the High Country Tek Inc. (HCT) *e-Fan* cooling systems controller user guide, and thank you for selecting this HCT controller to use in your application

The following information is designed to allow you to connect, set-up and optimize the emc-1P and emc-1V modules.

If you have used HCT products before, you will recognize some of the instructions and settings. For those of you that are new to HCT, please read the directions with care and be sure that if you have any questions regarding this industry unique controller, then please contact us using one of the numbers given on the back page of this manual.

We value our customers, their experience and abilities and ask that if you would like to see any additions, subtractions or find any errors in this publication, that you contact HCT's customer service so that we can correct the information and make sure that our programming community is using the latest information.

If you require urgent support, more information or would like specific programming areas clarified, you can contact us on the customer support number at 1 530 265 3236 or E-mail us through our website at www.hctcontrols.com, giving details of your issue and how we can contact you.

Introduction

This manual is designed to provide information needed for the installation and use of the emc-1P & emc-1V e-Fan Cooling System Controllers. Its intended user is qualified trained service personnel that understand the hazards involved in an electromechanical environment. It is recommended that this manual be read in its entirety before installation is begun with particular attention paid to caution and safety information.

Cautions

Changing setup values and limits under computer control while the machine is operating may cause sudden machine movement, which may lead to possible **injury** or **death**. It is strongly recommended that any moving parts are disabled prior to any alignment procedure whenever possible. In any case, caution should be exercised during any procedure and work should be completed only by qualified trained personnel.

Warranty Information

High Country Tek Guarantees this product to be free of defects in materials and workmanship for a period of one year extending from the date the unit was shipped from the factory. Within this time frame, High Country Tek will provide evaluation of warranted items free of charge. Warranty repair or replacement will be at the factory's discretion. If necessary, contact the factory for return authorization by phone (530) 265-3236, Fax (530) 265-3275, E-Mail info@hctcontrols.com or by writing our service department at, High Country Tek, Service Dept., 208 Gold Flat Court, Nevada City, CA 95959. To help us serve you better, please have the units full Model / Part Number and Serial Number available when contacting the factory for any reason. Do not return products to the factory without prior authorization and a RMA number attached.

Controller Updates:

HCT continuously improve the controllers and make additional information and/or features available. Please check on-line at www.hctcontrols.com for the latest products, updated software and controller information.



e-Fan Cooling System Controllers with J1939 Interface

'emc-1P & emc-1V' e-Fan System Controller

The emc-1P and emc-1V are the latest additions to the **High Country Tek (HCT)** family of **e-Fan** control modules. These highly cost effective controllers have all the features and input output functionality that will support a wide range and configuration of **e-Fan** system applications. As with all of the HCT modules, the controller is packaged in a small rugged enclosure and encapsulated in flame resistant resin to withstand extreme conditions in the harsh mobile operating environment.

The modules are ideally suited for today's OEM, distributor or system builder, with both mechanical and electrical robustness paramount in the design priority, Windows™ compatible easy to use set-up software and full CE compliance means this one product can be used across multiple platforms, markets and applications. This unit's cost effectiveness will become quickly apparent through the reduction in inventory costs and stocking needs as well as in the engineering time taken usually associated with the design to delivery cycle.

Programming of the controller parameters and all diagnostics is done through the RS232 connector pendant. This is a separate connector from the main or SAE J1939 connector (as fitted on the emc-1P) so that optimization or operational observation can be carried out without disturbing the cooling system operation. When programming, changes or observation of the module function is required, connection can be made through a standard computer serial connection, either directly via a 9 way 'D' type connector or through an HCT approved USB to serial converter. In all cases, the HCT programming interface cable (Part No: 999 – 10075, RS232 programming cable) is required for communication from the controller to a Windows™ based PC.

The controller is designed to make the fan system set-up easy to configure and control. The hardware contains the framework software where the parameters can be changed depending on the user's needs via the PC graphical user interface (GUI).

The GUI has been organized into various user screens that are logical and simple to understand. Terminology has been used that is commonplace through the mechanical, hydraulic, mobile and electric fan drive industry to allow easy configuration, set-up and running and is intended to cater for a wide range of users with varying levels of computer familiarity.

This controller is ideally suited to equipment upgrades as well as installation by OEM's at machine build time and offers all the necessary features required by today's modern engines that use the J1939 communications standard.

The controller will take information directly from the J1939 bus for the common temperatures broadcast such as Engine Coolant, Charge air and Transmission Oil Temperature making system integration very quick and easy. Engine RPM is also monitored by the module giving the user an option to control the engine load during the engine start cycle. (minimum RPM setting) Additional external inputs (1x emc-1P & 2x emc-1V) from Thermistors may be used to monitor non SAE J1939 temperatures and effect the fan operation.

The emc-1P & emc-1V products are backed by **High Country Tek's** industry leading product reliability, easy to use software design and market leading customer service and technical support as well as on-time delivery while the well designed and intuitive graphical user Interface (GUI), allows you to program multiple configurable modes of operation available within the one module.



Product Overview

- **NO software experience needed to apply this controller successfully.**
- Pre-written 'e-Fan Drive' software for easy, fast system configuration, development and production.
- Intuitive Graphical User Interface (GUI) runs on any PC with Windows® XP or newer software (.net compatible).
- 9 – 32VDC operation with full reverse polarity and **SAE J1455 protection.**
- **CE approved** to latest international test standards.
- **J1939 CAN Bus communications** for engine and temperature zone data Inputs
 - **J1939 temperature data hard coded for:
 - **SPN 109, Engine Coolant Temperature; PGN 65262,**
 - **SPN 177, Transmission Oil Temperature; PGN 65272**
 - **SPN 105, Engine Intake Manifold 1 Temperature; PGN 65270**
 - Extended -40°C (-40°F) to +85°C (+185°F) controller operational temperature range.
 - All inputs and outputs are protected from shorting to ground or the power supply.
 - Diagnostic LEDs display I/O status and module operation at a glance.
 - 'Blinking' error codes for fast on-site 'health check'.
 - System wiring and coil fault detection alarms.
 - Configurable Alarm output for integration into host system.
 - **IP68 (NEMA 6P)** rating on module for harsh environment reliability.
 - Deutsch IP69K connectors for reliable and easy system wiring.
 - Separate RS232 communications connector for programming, monitoring and diagnostics.
 - Rugged encapsulated product withstands harsh environments found in mobile applications.
 - Non Volatile Memory maintains ALL settings without power
 - Completely user configurable and settings are password protected.

****J1939 PGN Address Note****

If the standard SAE J1939 PGN address for Temperatures or RPM is NOT compatible for a particular application, HCT can change the PGN numbers as needed and re-issue personalized program code to you. Please use the contact numbers on the back page of this manual to discuss this with our customer support personnel.



e-Fan Cooling System Controllers with J1939 Interface

Product Application Guidelines

ALWAYS do the following

- Take a few minutes to FULLY read this manual and accompanying data sheets BEFORE starting.
- Keep High Voltage AC cables separate from Low Voltage DC signal and supply cables.
- Make sure the unit output voltage is compatible with the equipment being driven!
- Ensure that you are aware of the adjustments and consequences for the external equipment.
- Make sure you have the correct tools to do the intended job (i.e. P.C., software) etc.
- 'Isolate' this unit from all other equipment BEFORE any form of welding takes place.
- Check ALL wire connections to ensure there are no unintended SHORT or OPEN circuits.
- Check that the units supply voltage is CORRECT, 'ELECTRICALLY CLEAN' and STABLE.
- Operate the units within specified operating temperature for the best and most reliable performance.
- Ensure that any unused wires / terminals are terminated safely and not shorted together.
- Isolate the controller if ANY form of battery charging or battery boosting takes place on the vehicle.
- Ensure ALL connectors are wired correctly, secure, locked and connected.
- Observe all the set-up procedures in this manual for best operational results.
- Follow and abide by local and country health & safety standards – protect yourself and others!

NEVER do the following

- Arc Weld or Charge Batteries with this driver unit connected as damage can occur.
- Attempt to use this unit if you are unsure of electrical OR mechanical connections or expected operation.
- Use a power supply that is not rated for the correct required O/P current under full load.
- Allow wires TO or FROM the unit to short circuit (to each other or chassis/cabinet etc).
- Attempt to use this unit in areas of intense RF fields without adequate screening measures.
- Disconnect or connect wires to or from this unit unless it is isolated from the power supply.
- Use this unit in temperatures that exceed those specified as operation may be effected.
- Start this unit without ensuring ALL work areas are clear of personnel!

Software Safety

- The software has been carefully written to give the user the maximum system configuration flexibility while being transparent in operation and easy to use, even for novice system builders and operators.
- To ensure safety when using the software and to prevent accidental connection to another module that is not an emc-1P or emc-1V, rules have been written into the software to ensure correct operation at all times. **After program entries, cycle power, to ensure changes are accepted by the unit.**
- When the PC running the GUI is first connected to a powered controller, and before any data exchange can be allowed, a 'Handshake' takes place that confirms the internal software (BIOS) is compatible with the GUI software and only then allows the PC and the module to communicate and share data.
- If at any point during the process above an error or miss-match is detected, or loss of communication, the GUI software will indicate "OFF LINE" and NOT allow communications until the problem is corrected.



emc-1P & emc-1v Electrical Specification Overview

Board Style.....	High Country Tek unique size and mounting
Connector Type (Main)	12 way male Deutsch IP69K rated
Connector SAE J1939.....	3 way male Deutsch IP69K rated
Communication I/O connector RS232	4 way Packard MALE (Tower) connector on 6 inch Cable
Communication Type	Serial data at 57.6K Baud through PC USB/Serial port
Input Supply Voltage	9 – 32VDC (absolute maximums)
Input supply current.....	~200mA quiescent + valve currents
	Input supply protection SAE J 1455 & User supplied inline fuse (AGC5 or compatible)
Command Input type Main.....	SAE J1939 digital data OR
Command type additional - emc-1P.....	1 x external discrete Thermistor
Command type additional - emc-1V.....	2 x external discrete Thermistor
Thermistor types	2 wire Resistance variety only (see page 29)
Proportional Output Type / Range	
emc-1P.....	PWM / 33Hz to 500Hz, 0% – 100% Duty Cycle, 0 – 3000mA
emc-1V.....	Voltage, 0 – 5 VDC / 0 – 50mA (short circuit protected)
Alarm Output Type / Range	Discreet Active Low or High / 0 – 3000mA
Alarm Output Protection.....	Short protection to power and ground
'Reverse' input signal range.....	+5VDC to +V module supply momentary = ON
'Reverse' input signal impedance	20K Ohm to ground
'Fire Event' input signal range.....	+5V to +V module supply Fans turn OFF (0V normal Fan operation)
'Fire Event' input signal impedance	100K Ohm
'Ignition' input signal range.....	+5VDC to +V module supply = ON
'Ignition' input signal impedance	20K Ohm to ground
Digital Input De-Bounce (Hold Time)	150mS (triggered on rising edge)
Reverse Indicator output Type / Range	Discreet Active High / 0 – 3000mA
Reverse Output Protection.....	Short protection to power and ground
Industry Compliant	CE certification to latest standards SAE J1455 Load Dump
Environmental	Totally encapsulated unit for mechanical protection
IP rating	IP 69K
NEMA rating.....	6P
Humidity	95 – 100% Non-condensing
Storage Temp range	-60 to + 90°C
Operating temp range	-40 to + 85°C

Note:

ALL controller and system response adjustments are made through graphical user interface software. See 'emc-1P & emc-1V Software' section in this manual for full details.

emc-1P Module Familiarity

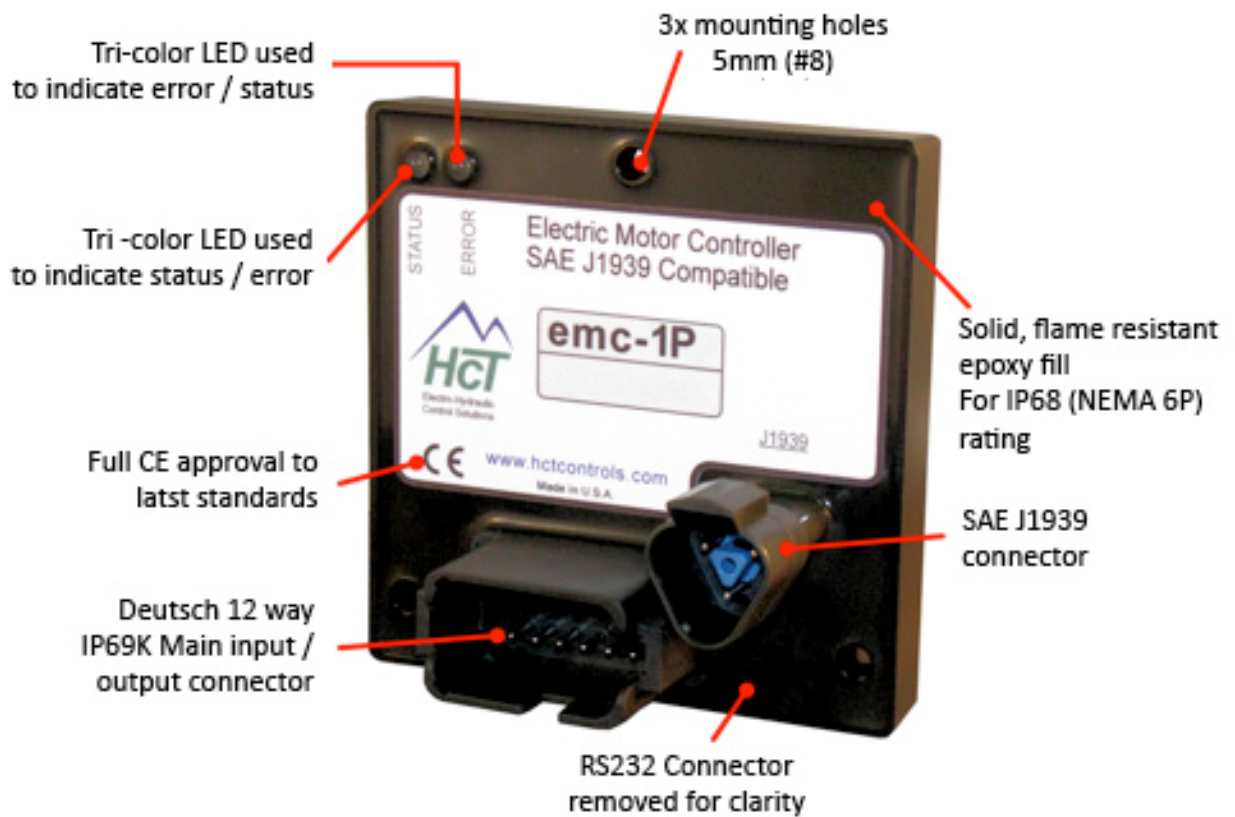

emc-1P Connection Information

NOTE: Controller MUST have in-line fuse fitted by user in the +V Power Input for system protection.

SAE J1939 Connections

- Pin A CAN_Hi (SAE J1939)
- Pin B CAN_Low (SAE J1939)
- Pin C No connection

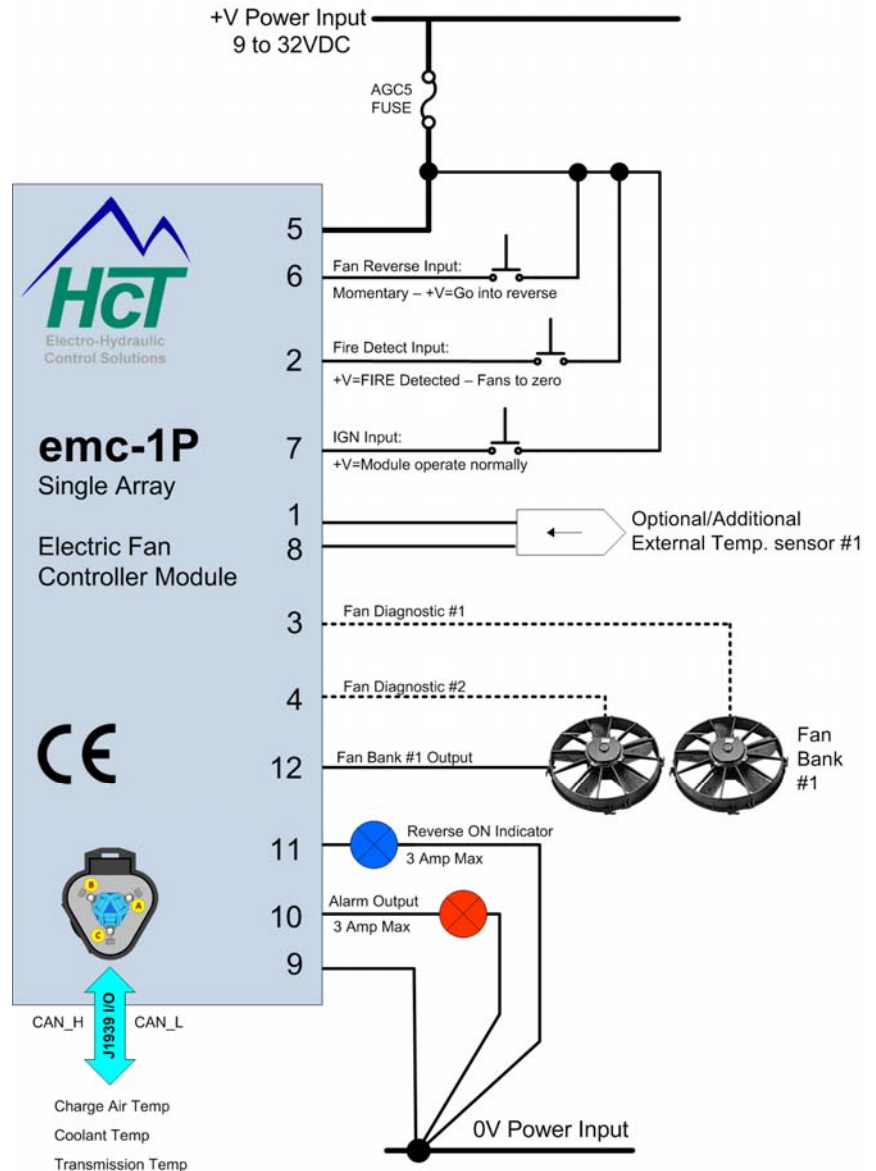
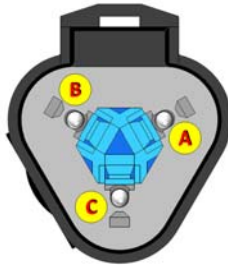

- Pin 1Sensor #1 +signal input
- Pin 2Fire detect input
- Pin 3Fan #1 Diagnostic input
- Pin 4Fan #2 Diagnostic input
- Pin 5+Volts 9-32VDC input
- Pin 6Reverse fan input (momentary)
- Pin 7Ignition ON input
- Pin 8Sensor #1 common
- Pin 9Power supply return (GND)
- Pin 10Alarm output (3A max sourcing)
- Pin 11Reverse output (3A max sourcing)
- Pin 120-100% PWM e-fan output

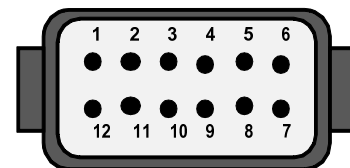

emc-1V Module Familiarity

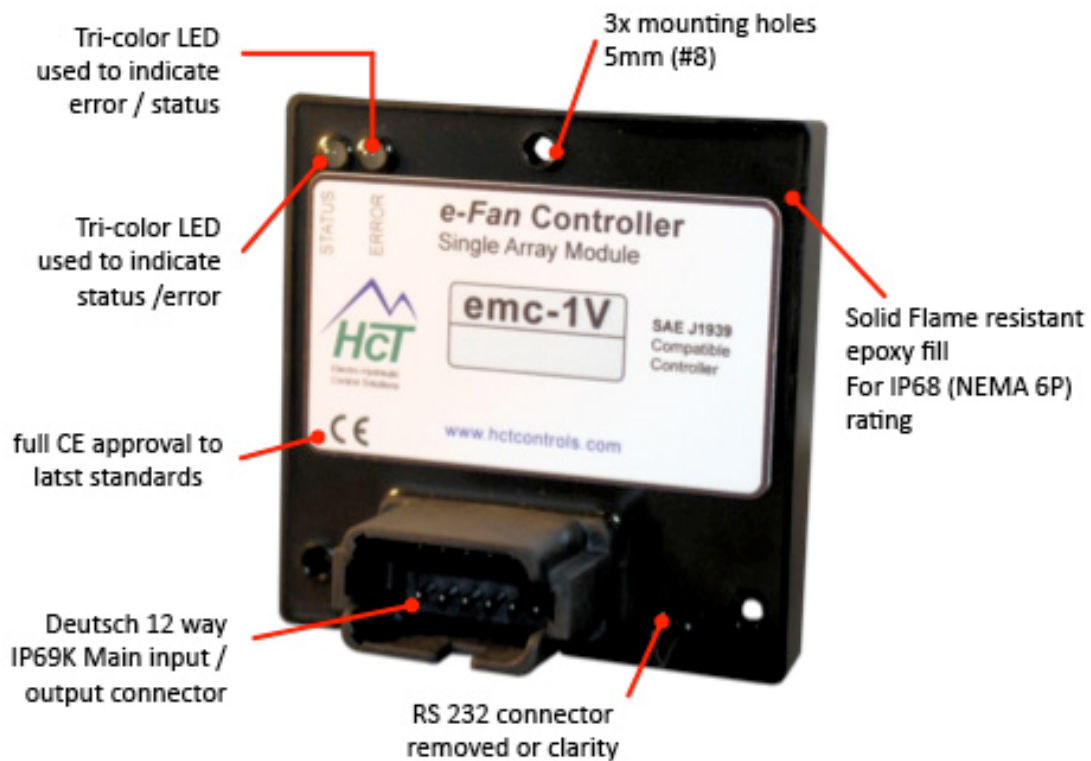

emc-1V Connection Information

NOTE: Controller MUST have in-line fuse fitted by user in the +V Power Input for system protection.

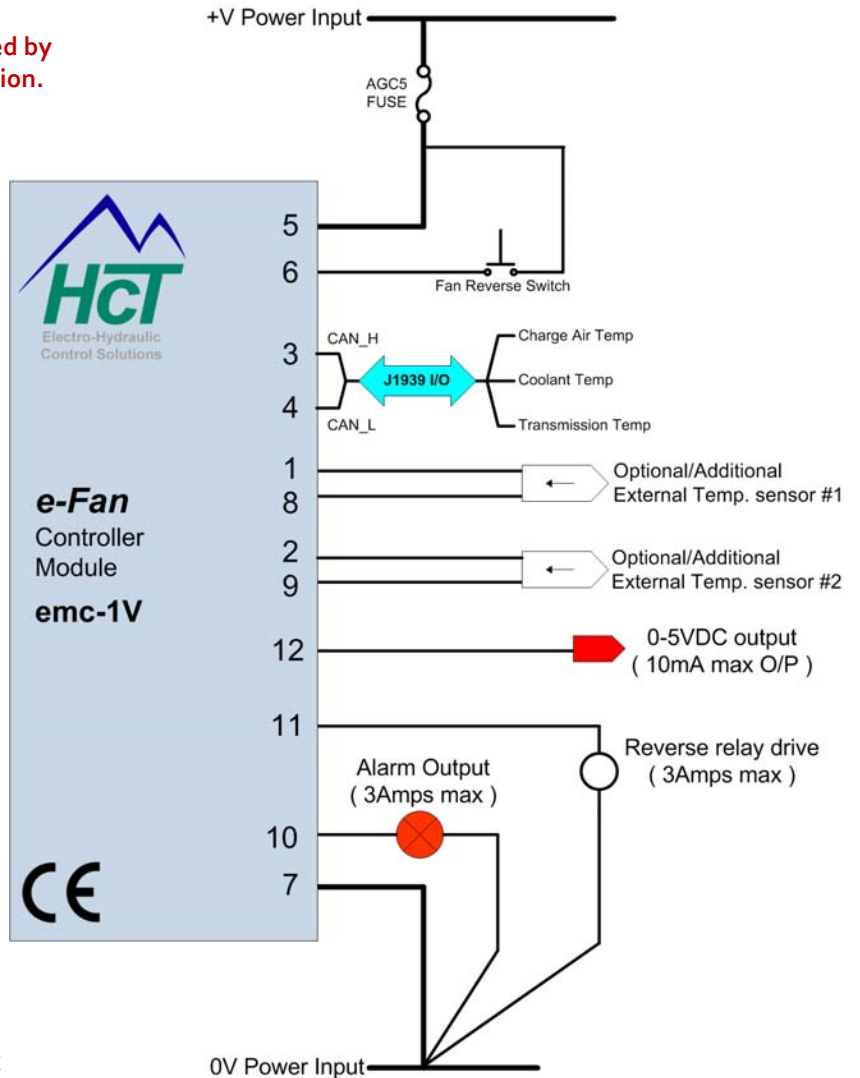
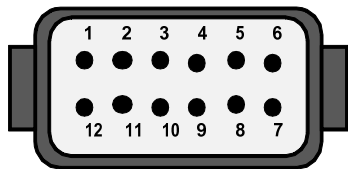

- Pin 1 Sensor #1 +signal input
- Pin 2 Sensor #2 +signal input
- Pin 3 SAE J1939 HI input
- Pin 4 SAE J1939 Low input
- Pin 5 +Volts 9 to 32VDC power supply input
- Pin 6 Reverse fan input (momentary)
- Pin 7 Power supply return (GND)
- Pin 8 Sensor #1 signal common
- Pin 9 Sensor #2 signal common
- Pin 10 Alarm out (3A max sourcing)
- Pin 11 reverse out (3A max sourcing)
- Pin 12 0-5VDC e-fan out (10mA)

Error LED Code Descriptions for emc-1P & emc-1V



Status Led	Error LED	Description	Alarm Out	Fan Out	Reverse operation
Static	off	Normal Operation	off	normal	normal
Flashing	off	Reverse Cycle	off	rev cycle	cycle On
Static	Static	Fire Input on	on	off	off
Static	Static	Thermistor open/short	on	maximum	normal
Static	Flashing	Fan Diag. Error	on	retry	normal
Static	Flashing	Alarm out short	off	normal	normal
Static	Flashing	Reverse out short	on	normal	off
Static	Static	Can message Timeout	on	maximum	normal
Flashing	Flashing	Cooling system over-temp	on	maximum	manual only
Static	Static	Module over temp	on	normal	normal

Note: * Fire input is available on the emc-1P only.



Module Connection Descriptions

Sensor #1 Input (emc-1P & emc-1V)

This input is designed to allow non SAE J1939 connected zones to be measured if required. The input accepts a standard NTC thermistor. This input should be referenced to the Signal Ground (0V) on the connector. The GUI is used to select / de-select and set-up the signal from this additional input and how it effects the fan speed control. **Note:** Use Pin 8 for signal ground as the reference for temperature sensor #1.

Sensor #2 Input (emc-1V only)

This input is designed to allow non SAE J1939 connected zones to be measured if required. The input accepts a standard NTC thermistor. This input should be referenced to the Signal Ground (0V) on the connector. The GUI is used to select / de-select and set-up the signal from this additional input and how it effects the fan speed control. **Note:** Use Pin 9 for signal ground as the reference for temperature sensor #2.

SAE J1939 High

This is the High side of the J1939 CAN Bus communication port. The cable used should be suitable for this type of data connection. Reference, SAE J1939/01 3.1.8, J1939/11 and J1939/31, Please observe proper Bus protocol including correct termination.

NOTE: The emc1P & emc-1V DO NOT have terminating resistors fitted – these must be system supplied by others.

SAE J1939 Low

This is the Low side of the J1939 CAN Bus communication port. The cable used should be suitable for this type of data connection. Reference, SAE J1939/01 3.1.8, J1939/11 and J1939/31, Please observe proper Bus protocol including correct termination.

NOTE: The emc1P & emc-1V DO NOT have terminating resistors fitted – these must be system supplied by others.

Power Supply Input

This terminal is the **Main +Supply** Voltage input on the controller. To provide the best possible noise resistance and current capability, this input should be taken directly to battery Positive or the power supply +V output using a large current capacity cable. An ACG 5, ATO 5 or compatible fuse should be installed as close as practical to the originating power source.

Range – 9 to +32VDC

Note: Failure to install a proper fuse in-line with the controller will void the warranty.



Fan Reverse Switch Input (Momentary contact)

This is a momentary signal input and only required that the input be pulled to +5V or Supply Power Supply for approx. 500mS to initiate the reverse sequence settings, this input is debounced in the module software to avoid false triggers.

This input may normally be referenced to chassis ground

Fire Detect Input: (emc-1P only)

Signal input must be pulled to +5V or Supply Power by the fire event. This will turn OFF the Fans. This is not latched and will return to normal operation when off. (0V)
Connect to PWR common 0V (GND) if not used.

Ignition Input

Ignition input must be pulled to +5V or Supply Power to enable operation.
This is not latched, emc-1 will not be enabled when off.

Power Ground Input, (0V)

This terminal is the **Main Power Ground** or Power Common (0V) input on the controller. To provide the best possible noise resistance and current capability, this input should be taken directly to battery Negative or the power supply 0V (GND) output using a large current capacity cable. DO NOT use a connection to chassis or false operation may occur.

Alarm Output

This output can SOURCE up to 3 amps at supply voltage and can be used to connect to an audio device or light indicator to show the systems alarm condition. This output can be set active High, or active Low. Output is reverse polarity and short circuit protected.

Reverse Indicator Output

This output can SOURCE up to 3 amps at supply voltage and can be used to connect to an indicator or alarm to show reverse status. This is a normally OFF, output will go to supply voltage when energized. Output is reverse polarity and short circuit protected.

NOTE:

The Alarm and Reverse Outputs, will source a small amount of current when OFF. The current available at 32 volts would be ~500uA and ~200uA at 12 Volts. This small amount of current should be considered when driving high impedance inputs or high efficiency LEDs.

Proportional Output; The function of this pin is dependent on the model in use.

emc-1P

This is a proportional Pulse Width Modulation (PWM) output that vary between 0 to 100% and can **source up to 100mA** and is intended to drive the command input of a 'Smart' electric fan that requires a low level PWM input for control. The PWM frequency is adjustable from 33 to 500Hz through the GUI. This output is reverse polarity, short and open circuit protected.

emc-1V

This is a proportional 0 to 5 Volt DC output that is capable of driving up to **10mA (or loads up to 100Ω)** and is intended to drive the command input typically seen on VFD converters. This output is reverse polarity, short and open circuit protected.

Serial Communications

Controller monitoring, health checks, diagnostics and set-up can be accessed through the supplied GUI. This program will operate on PC using a Windows® based operating system and is password protected to maintain module parameter integrity by only allowing authorized users to access different levels of the controller settings.

The interface is designed to be simple to use and follows the familiar Windows® menu format with drop down option screens to select the various options available at the user level allowed.

Explanations of the screens are covered in detail, later in this guide.

Once the PC has been connected to a 'live' controller, and the GUI program started, a free communications port will be allocated and communication with the GUI will begin.

Users running a computer without a 9 pin serial port **MUST** use one of the following approved RS232/USB adaptors:

Manufacturer	HCT Part Number	Notes
CommFront	108-00119	CE certified RoHS compliant

After communications have been established, the user will be presented with the initial information screen that will give all the basic information needed to assess the health of the system.

Real time graphing is available to monitor a wide range of items (selectable from a drop down list) and for remote diagnostics, a 'Data Log' button will start a Windows CSV file that can be used as a monitor for comparison to other logged charts during the system's life or can be E-mailed to an engineering source for interpretation of system efficiency.

Passwords protect the settings of the module at all times and are needed to make any changes to the operational parameters.

RS232 Serial Connection Cable: Part No- 999-10075 (see page 33 of this manual)

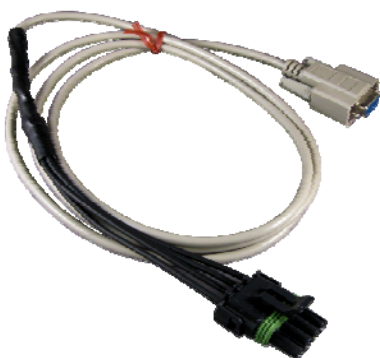

Pin	Function
A	Received data
B	Signal ground (Common)
C	Transmit data

NOTE: The 4-pin shroud Weatherpack connector from the controller has MALE pins, therefore the mating cable needs to terminate in a Tower Weatherpack connector with FEMALE pins.



e-Fan Cooling System Controllers with J1939 Interface

Loading the emc-1P or emc-1V GUI onto Host PC

Both controllers are set-up via a common GUI interface for ease of use.

GUI P/N: 023-00264

The PC **Graphical User Interface (GUI)** is a self-extracting and installing program that will reside on the chosen host PC hard drive. It is recommended that the user allow the defaults to be used for easy future update installation, but the option is given to allow the user to choose where the program should be located.

It is **NOT** recommended that this program be run from a network as it needs access to certain files available only in the Windows directories.

To start the installation process, insert the CD ROM or if this does not work, search for the “setup.exe” Application and ‘run’.

System Requirements

Windows XP, Vista or Windows7

256MB or greater

Serial Port RS232 or USB Adapter

RS232 Serial Cable PN: 999-10075

Controller adjustments and Monitor

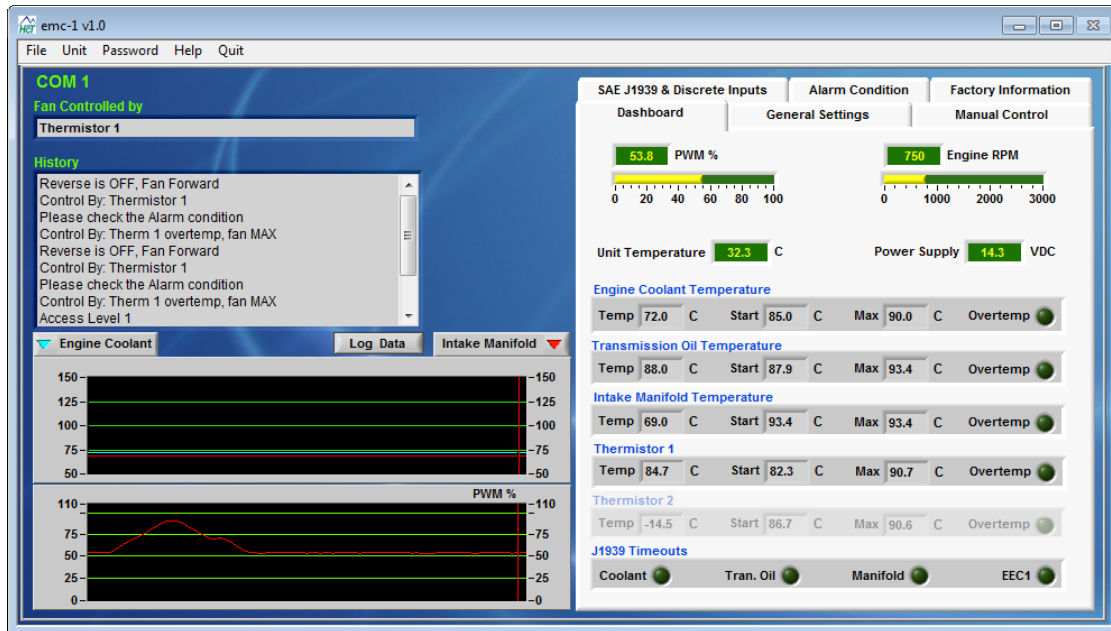

After program entries cycle power to ensure changes are accepted by the unit.

GUI Menu Options

File

-> Read file or Save File

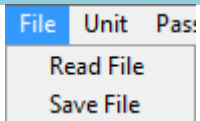

The user has two simple options available:

1) Read settings from file.

This option allows the user to search for and find preciously saved settings files (*.DAT) and to load them into a new controller or to reset a controller to a previous version e.t.c.

2) Save settings to file.

This option allows the user to save the current settings displayed on the GUI while connected to a controller to a file name and destination of choice for retrieval at a later time.

These *.DAT files may also be E-mailed if required to other users to duplicate settings that may have been optimized or changed.

-> Find Controller

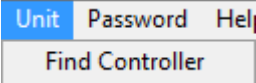

Will search the com ports, find the controller, and read settings. *Helpful if you have lost communication and or want to do a clean read.*

Password Protection

Enter Password

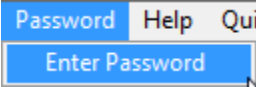

Password entry is started by clicking the 'Password' option in the top bar of the GUI screen. This will open a box to enter the passwords.

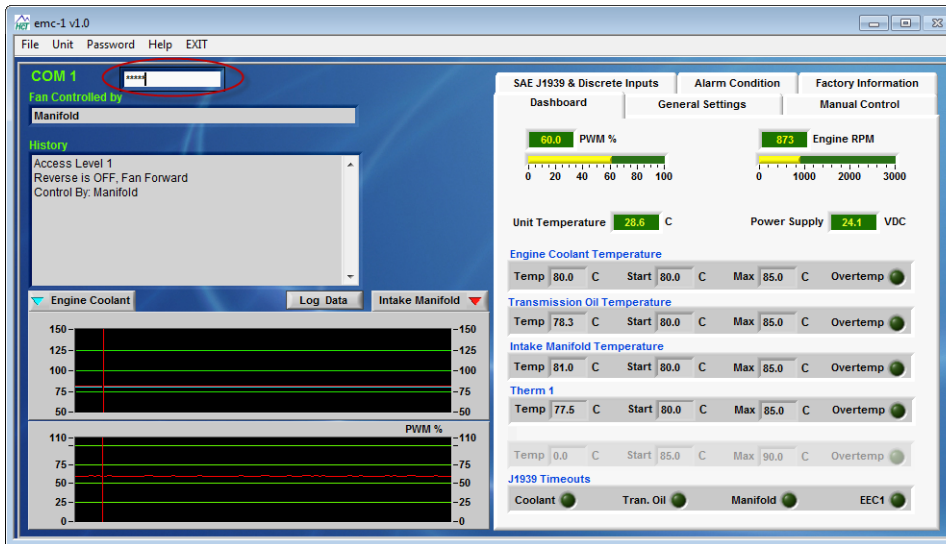

Passwords are 'cAsE SeNsitive' so ensure you have the 'Caps Lock' off if required.

Level 0) - NO Password

This allows the user to view the current operational, settings, and alarms. Operator may use the help menu and log data. Cannot change settings or load new file.

Level 1) – OEM password (supplied with unit or contact HCT)

Access at this level gives the user full viewing as above and **also allows changing of all of the system settable parameters**. This includes the resetting of the OEM password. Does NOT allow resetting of highest values recorded. This is module warranty information for HCT.

Level 2) – High Country Tek Inc. (Safety Reset) Password

This level of password overrides all other password levels and allows HCT authorized personnel to access the module and the software when required for factory settings.



e-Fan Cooling System Controllers with J1939 Interface

Menu Option

->Help

Help

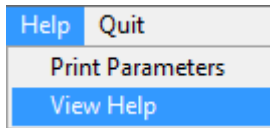

View Help

This option directs you to emc-1 manual that is part of the installation package. You may add your own docs by adding word.doc or other .pdf files to the same folder. (c:\HCT Products\Fan Drives\emc-1)

Print Parameter

This will print all settings to your PC default printer. Or print to a text file, tab delimited. The text file may be viewed with Notepad, Word, or Excel. You could also set your default printer to 'Adobe PDF' for storage on your PC.

->Quit or EXIT

This will insure that the unit is not left in the manual mode, it will then close the GUI and release the communication port for future use.

GUI software – Main screen (Dashboard)

The software has been designed such that there is NO nesting of menus so that it is easy to navigate around the different screens without getting lost or having multiple windows open at any one time. The five main screens are available via 'Click Tabs' from the 'Dashboard' and are:

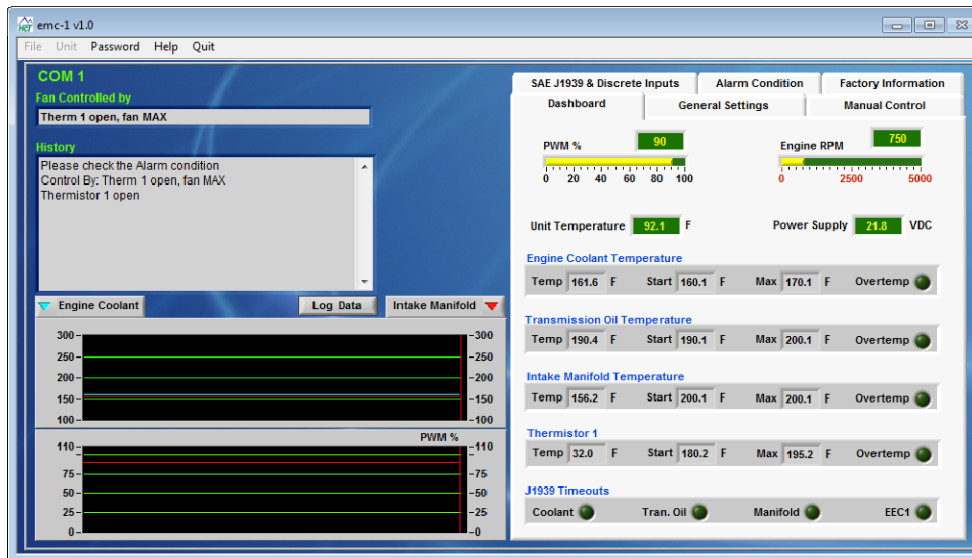

The '**Dashboard**' tab provides a quick user overview of the controller operation, system status and condition of the J1939 data Bus. Error indicators change from Green (OK) to Red (error or alarm) with an over temperature or a J1939 message timeout.

Fan Controlled by:

Displays what attribute is currently controlling the Fan.

History

Continuous updates of all changes in module operation as they happen, new changes are reported at the top.

Graphs

There are two graphs displaying Temperature and PWM%. You may select which two Temperatures that you want to monitor.

Each signal displayed will have a color coded individual scale on the 'Y' axis.

The History and Graphs are providing vital information on the operational status of the emc-1.



e-Fan Cooling System Controllers with J1939 Interface

Data Logging

Start a data log by clicking on this button, data logging will continue until it is turned off by using the same button now labeled “Logging Data”

- Module Input Voltage
- Module Internal Temperature
- Proportional Valve Current
- Thermistor #1 Temp I/P (Actual)
- Thermistor #2 Temp I/P (Actual)
- J1939 Coolant Temperature (Actual)
- J1939 Inlet Manifold Temperature (Actual)
- J1939 Transmission oil Temperature (Actual)

Note: you may also right click on the graph at any time to capture a window in spreadsheet format.

The file type will be saved as tab delimited file and may be viewed by any text editor or copied directly into Excel for examination.

The user should be cautious when using this LOG function as the files can become very large if logging is left to continue for long periods, making the files difficult to read and manage.

Experience has shown us that several smaller logs over adjacent periods are easier to manipulate and view as graphical data.

General Settings

Selection Tab -> **General Settings**

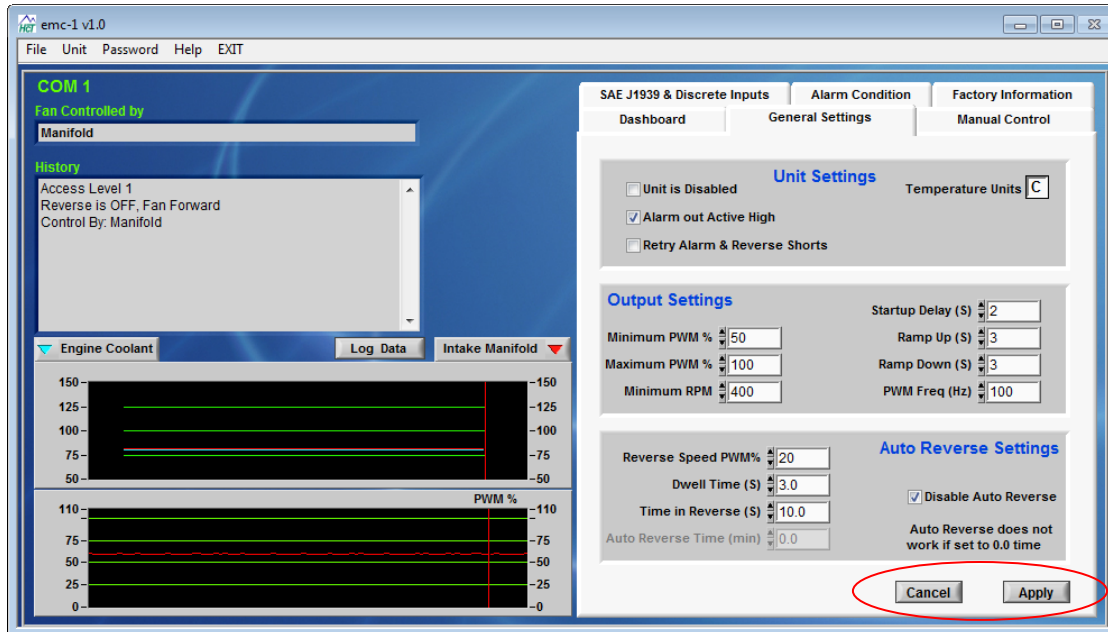

On each tab changes must be 'Applied' to take effect. Cancel will restore values.

Unit Settings

Unit Disabled

The controller is shipped in a disabled state and should be enabled by the OEM or user by using the GUI. Once this button is selected, the date from the enabling PC is taken and used as the 'Born Date' when warranty starts.

Alarm Active High

This sets the default state of the alarm output to allow normally OFF or normally ON devices to be driven. When enabled, the output is HIGH when alarm condition exists and LOW with NO alarm condition.

Retry Alarm and Reverse Shorts

If not checked and a short is detected on the Alarm output or the Reverse Indicator output, the software will stop driving that circuit until a power cycle. Thus preventing damage to external hardware from high current or overheating. This does not affect fan control.

Temperature Units

This setting selects either degrees Fahrenheit or degrees Centigrade and ripples through all the settings that deal with temperature.



e-Fan Cooling System Controllers with J1939 Interface

Output Settings

Refer to the requirements set by the fan manufacture for the following 3 adjustments:

- 1. Minimum PWM% (0-100%) output**
- 2. Maximum PWM% (0-100%) output**
- 3. PWM Freq (33-500Hz):** This is the 'dither' or operating frequency for the PWM% output.

Minimum RPM (50-4000RPM)

This value is the engine RPM needed before the fan controller will start to operate above the minimum system speed set by the motor pressure drop – this reduces the load on the starter motor.

NOTE: Information for this feature is taken from the J1939 Bus and cannot be used if not connected.

Start Up Delay (0-30 seconds)

Delay action is only triggered once when power is first applied to the module i.e. at key ON engine start time. This feature is designed to reduce the load on the starter motor by holding off fan operation until the time set has expired.

Input 0 to 30 seconds

Ramp UP & Down (0.5-30 seconds)

This will affect the output rate of change. These should be set to give smooth operation but not too long or performance will be affected by slowing down fan speed response.

Auto Reverse Settings

Dwell Time (0-60 seconds)

This is the time that the controller allows for the fan to get to minimum speed before changing direction when entering or leaving the reverse mode.

Time in Reverse (0-120 seconds)

Sets the duration for fan reverse operation.

Auto Reverse Time (1-1440min)

Sets the wait period between fan reverse cycles.

Disable Auto Reverse

When checked this will set the Auto Reverse Time to 0.0 and not allow the use of the setting.

Note: If J1939 messages are enabled, the RPM must be above minimum RPM setting for fans to work in the forward or reverse direction.

With an over-temp alarm active, only the manual input will start a Reverse Cycle. Auto Reverse is disabled.

Input Settings

Selection Tab -> **SAE J1939 & Discrete Inputs**

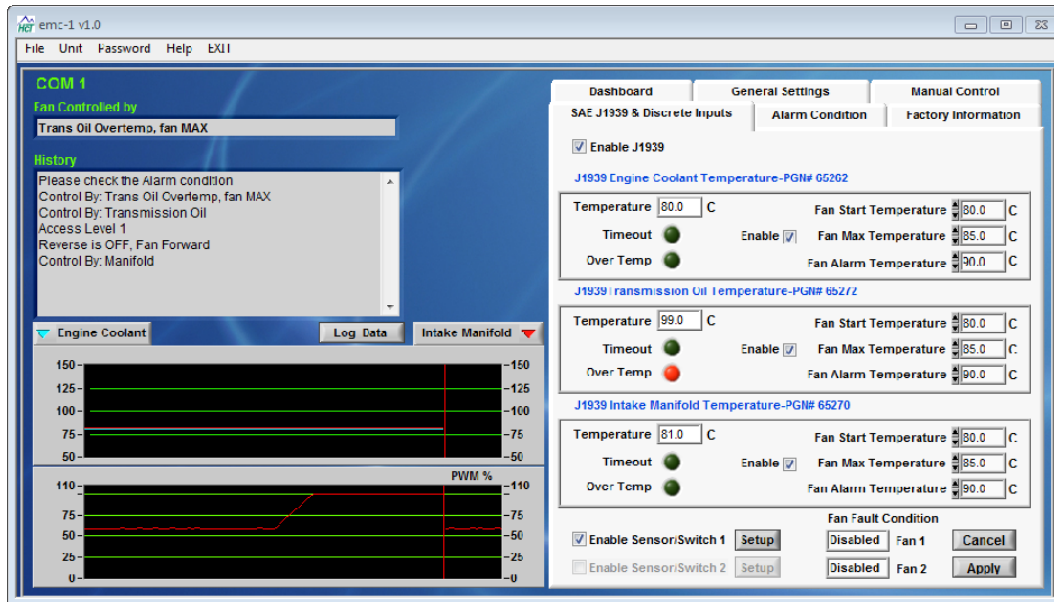

Settings do not take effect until Applied

Enable J1939

This option **MUST** be clicked if the unit is to understand the J1939 Bus information. If this button is **NOT** clicked, all J1939 features are disabled in the controller.

Note: If J1939 messages are enabled, the RPM must be above minimum RPM setting for fans to work in the forward or reverse direction.

Temperature settings

The emc-1 has 3 J1939 Bus messages and Thermistor inputs that can be individually enabled or disabled as required.

- **Engine Coolant temperature at PGN 65262, SPN 109**
- **Transmission Oil temperature at PGN 65272, SPN 177**
- **Intake Manifold temperature at PGN 65270, SPN 105**

Output PWM% to the fan is controlled between 'Fan Start Temperature' and 'Fan max temperature' and is a linear line between these two set values.

Fan Fault Condition

Set this for the fault condition that your fan will produce as the diagnostic input for Fan 1 or Fan 2.

Depending on the fan type it will either do nothing, **Open**, or will drive the input **Low** or **High** to indicate a fault.

Set to **Disabled** if not used.

Sensor setup

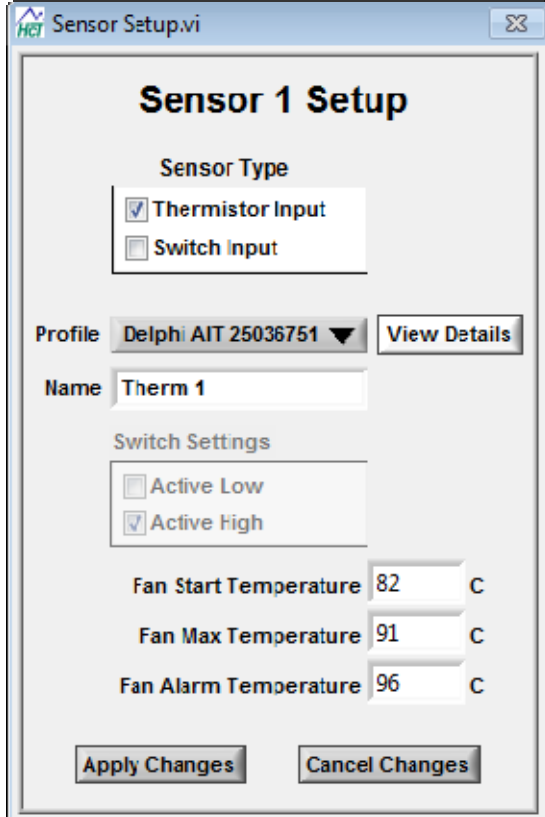

The screenshot shows the 'Sensor Setup.vi' window with the following configuration for 'Sensor 1 Setup':

- Sensor Type:** Thermistor Input, Switch Input
- Profile:** Delphi AIT 25036751 (with a 'View Details' button)
- Name:** Therm 1
- Switch Settings:** Active Low, Active High
- Fan Start Temperature:** 82 C
- Fan Max Temperature:** 91 C
- Fan Alarm Temperature:** 96 C
- Buttons:** 'Apply Changes' and 'Cancel Changes'

Allows for a switch input or a thermistor input and name for either. Name is useful in data logging and on the Dashboard monitor.

As a Thermistor input:

Check the Thermistor box, then select profile type from pull down menu, and enter the Start, Maximum, and Alarm temperature values, then Apply Changes.

As a Switch input:

Check the Switch box, then select Active High or Active Low for the input. Enter a name if desired, then Apply Changes

Apply Changes will save to the unit and close this window. Or Cancel Changes to close window without applying.

Error Information Log

Selection Tab -> **Alarm Condition**

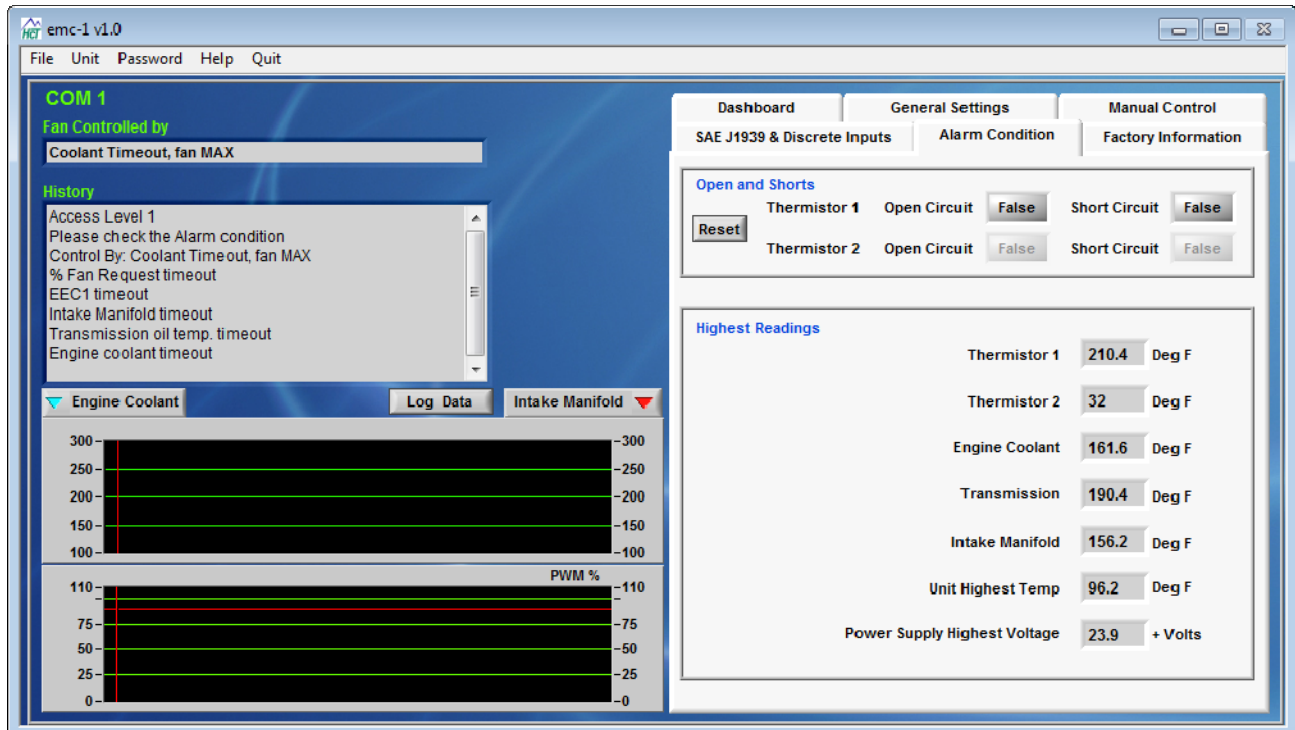

This page shows the user information that will help to track and where necessary, fix intermittent opens and short circuits on any of the wires used to connect to the sensors, switches or the coils in the system.

The program shows where the error has been seen, even if the error has cleared itself. The information can be cleared by the user with the appropriate password level by clicking the 'Reset' button in the Opens and Shorts section.

Highest Readings are stored permanently in the modules memory and cannot be reset by the user. These are the maximum values seen on several key areas including the module health, and are only overwritten by higher values.

Factory Information

Selection Tab -> **Factory Information**

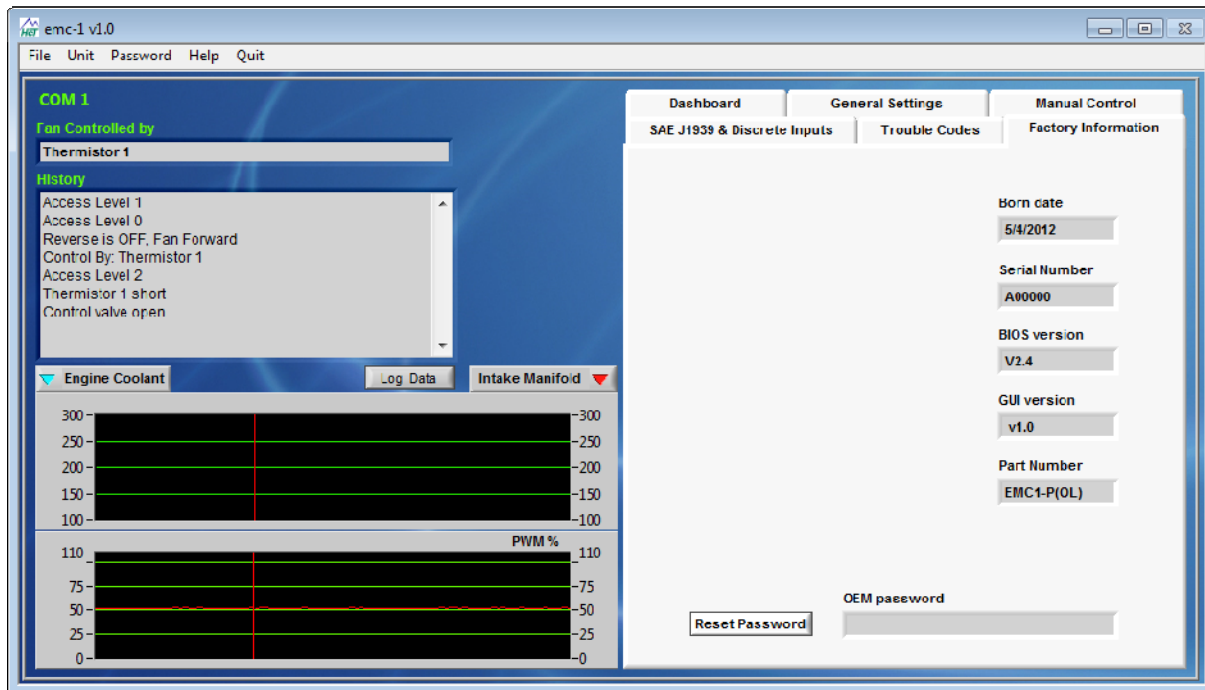

This page allows the user to view information concerning the controller serial number, GUI Part number, BIOS and Graphical user Interface (GUI) software versions as well as the 'Born Date,' which is taken from the local PC used to activate the module.

This information should always be available when requesting support so that HCT personnel know the level of controller with which you are working.

Temperature Sensor Information

HCT P/N: 206-00083, Wet fluid temperature sensor.

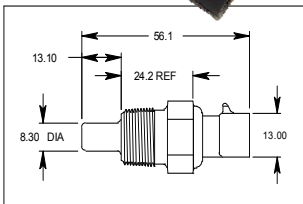
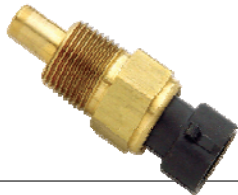

Housing Type:	Delphi Unique	Sensor Body:	Brass
Typical supply voltage:	+5VDC	Connector Body:	PBT 30% Glass Filled
Dissipation Constant*:	24mW/°C	Hex Size:	18.9mm / 3/4"
Thermal Time Constant**:	17.5 to 23.5 seconds	Thread Size:	3/8' - 18 NPTF
Temperature range:	-40 to +150 °C (operational)	Thread Sealant:	GM09985473
NEMA/IP Rating:	NEMA 6P/68	Sealing Pressure:	145kPa
		Installation Torque:	20Nm
		Overall Weight:	40g

Contact HCT customer service for more sensor options and information

HCT P/N: 206-00084, Dry fluid temperature sensor.

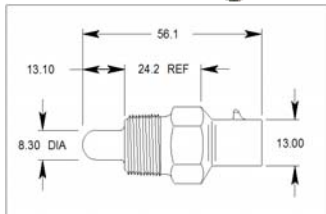

Housing Type:	Delphi Unique	Sensor Body:	PEI (polyetherimide) 30% Glass Filled
Typical supply voltage:	+5VDC	Connector Body:	PBT 30% Glass Filled
Dissipation Constant*:	18mW/°C	Hex Size:	18.9mm / 3/4"
Thermal Time Constant**:	60seconds	Thread Size:	3/8' - 18 NPTF
Temperature range:	-40 to +150 °C (operational)	Thread Sealant:	GM09985490
NEMA/IP Rating:	NEMA 6P/68	Sealing Pressure:	145kPa
		Installation Torque:	10.8 - 16.3 Nm
		Overall Weight:	13.2g

Main I/O connector & Accessories

Mating connector Parts information: Complete harnesses and connector kits can be supplied by HCT. Please contact customer service for information.

System Accessories for emc-1P and emc-1V:

Item Description:	HCT P/No:
SAE J1939 connector kit for the emc-1P	999 - 10244
RS232 Communications Cable - Weatherpack	999 - 10075
emc-1Main Mating I/O connector Kit	999 - 10155
emc -1Graphical User Interface (GUI) replacement Disk	023 - 00264
emc -1Operating Manual	021 - 00351 (see website for latest version)



On Site Testing

If the set up procedure does not achieve the desired results, double check the wiring and perform the following tests. Record the test results.

Tools Required:

A PC running Windows XP, Vista, or Windows7 and the correct emc-1 software are required for initial set-up, programming or observation of the controllers operation through the RS232 port (directly or via a USB to serial converter cable).

The PC can also be used for uploading the configured program to new emc-1 modules for upgrades.

A battery operated multi meter is always a good idea for measuring and confirming analog signals and an oscilloscope would be useful for looking at fast moving or digital signals on the system.

Check the Power input: (9-32V)

If the supply voltage is below 9VDC, there is a risk of:

- a) Module shutting down,
- b) Module continuously trying to reset or
- c) Low drive current to valves.

If the supply voltage is more than 32 VDC there is a risk of:

- a) Blown in-line AGC5 fuse
- b) Module shutting down.
- c) Fan damage due to excessive drive voltage.

Check the Control Inputs:

Verify that any analog control inputs are the correct polarity and are hooked up correctly and to the correct module terminals by monitoring their status with the emc-1 software or testing with a voltmeter or oscilloscope.

Ensure the J1939 Bus is terminated correctly (120 ohm resistors) and that the engine is running to ensure good data.

Ensure that any external control or command inputs have their respective sources 0V or GND connected to the modules power supply 0V or GND terminal.

Verify That Alarm or Reverse Indicator Loads are Not Shorted:

Disconnect the wires going to the terminals and measure the resistance between the wires. Verify it is in the expected Ohmic range for the type and voltage of load being driven. Verify that there is no voltage with respect to ground generated by the load and wiring.



***e-Fan* Cooling System Controllers with J1939 Interface**

If the e-Fan Operation is Erratic:

Electrical interference on the control lines can cause erratic behavior if it is strong enough. Observe the control inputs on the PC. If noise greater than a few percent is noticed on an unchanging PULSE IN or COMMAND IN input, or if the digital inputs are toggling, try changing the routing of the control wires to see if the problem changes.

Power supply interference or brown outs can also cause erratic behavior. Observe the power supply on the graph on the PC. If large dips are noticed, test for a poor supply by running the card off its own fully charged battery.

Further Information:

Visit the HCT website (www.hctcontrols.com) for additional documentation and assistance.

emc-1P & emc-1V Dimensional Information

Label	Inches	Millimeters
A	3.77	96.0
B	1.625	41.3
C	∅ 0.186	4.7
D	3.82	97.0
E	3.10	78.7
F	0.46	11.7
G	3.25	82.6
H	2.125	54.0
I	0.64	16.3
J	0.26	6.6

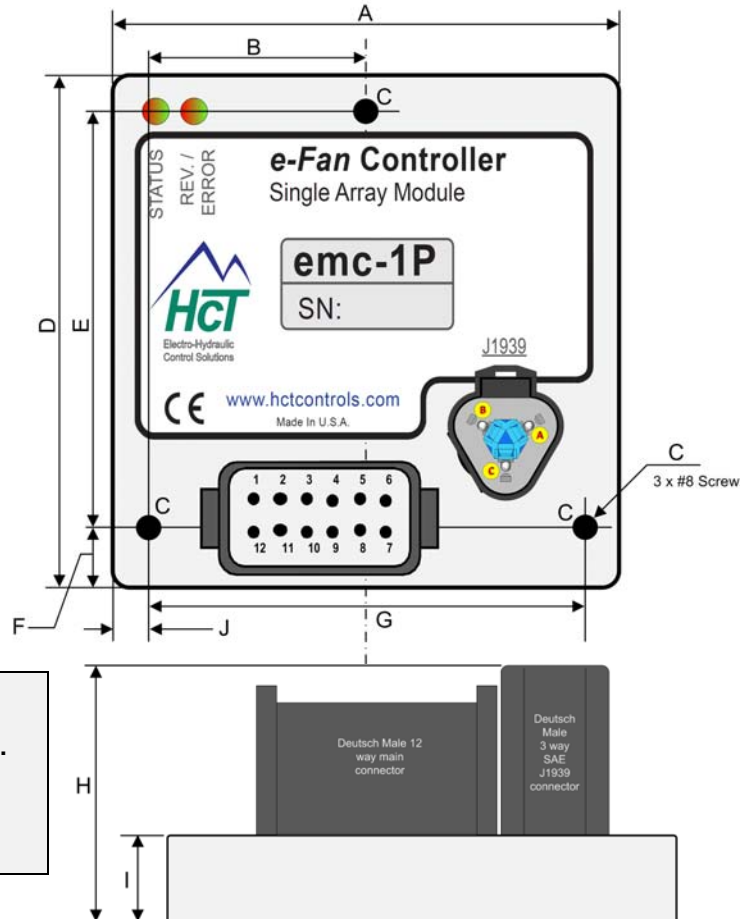

- Notes:**
- Mount controller as shown or with connector facing down to avoid surface debris collecting.
 - Unit weight is approx. 250 grams
 - RS232 cable removed for clarity
 - RS232 cable is approx 6" long

- Housing Type** High Country Tek unique ‘encapsulated’ block
- Housing Material**..... None, solid, flameproof epoxy resin block
- Housing Color** Black / dark Grey
- Surface Finish**..... Smooth Gloss
- Housing Thickness**..... 16.5mm (main module) ~41.5mm incl. Connectors
- Unit Size**..... See above size detail drawings
- Unit Weight**..... Approx. 250 grams (including Encapsulation material)
- Wire Entry**..... Industry standard 12-way Deutsch, sealed connector
- Encapsulation** Flame Resistant, Black, Two-Part Epoxy Resin
- Mounting**..... Via through holed (3) suitable for No. 8 (5mm) screw
- Temperature Range**..... - 40 to +85 degrees Centigrade (operational)

RS232 Communication Cable

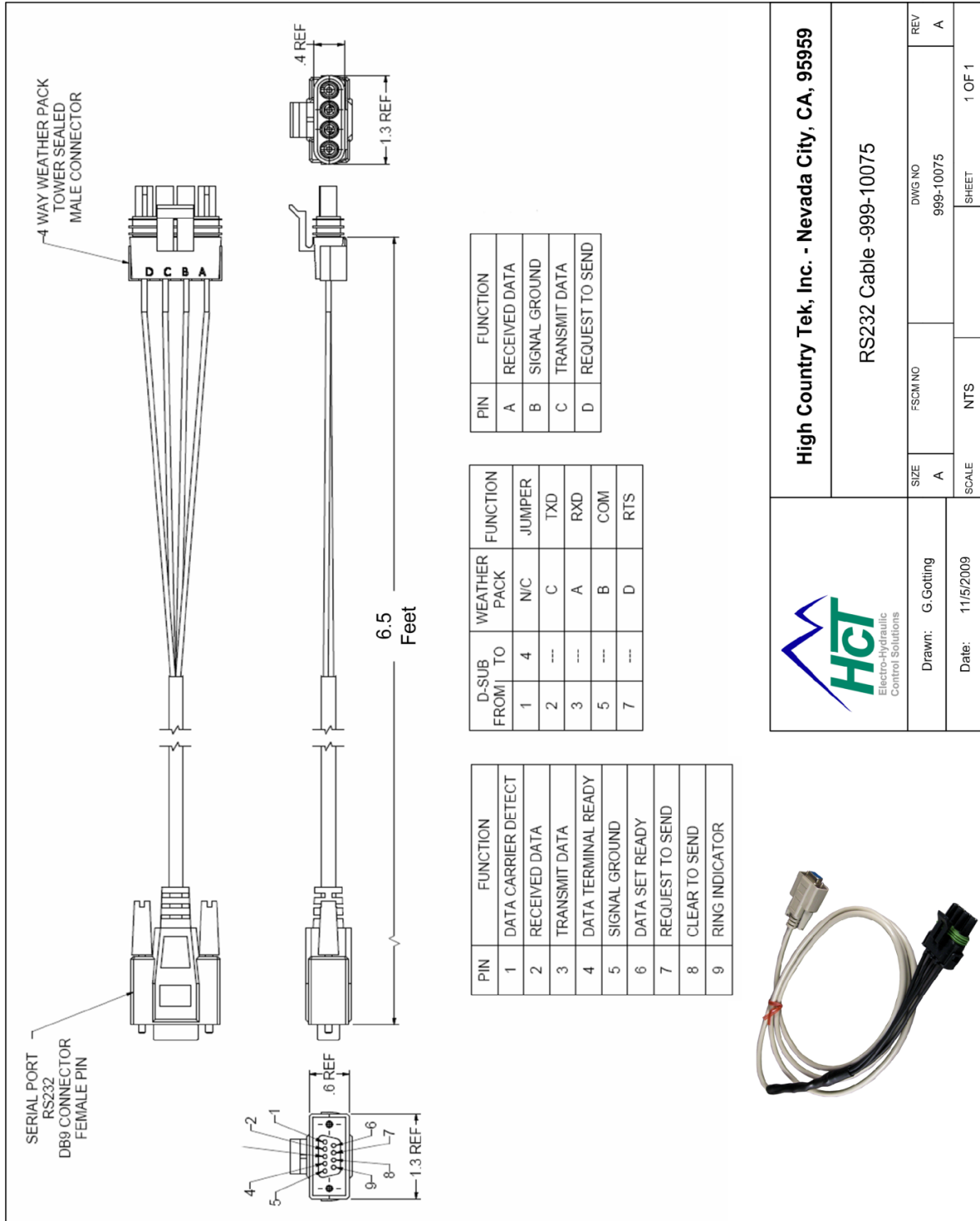

High Country Tek, Inc. - Nevada City, CA, 95959

RS232 Cable -999-10075



SIZE	FSCM NO	DWG NO	REV
A		999-10075	A
SCALE	NTS	SHEET	1 OF 1
Date:	11/5/2009		



Electronic Control Solutions for the Global Fluid Power Industry

- ❖ Mining & Exploration
- ❖ Agriculture
- ❖ Cranes & lifts
- ❖ Refuse & Re-cycling
- ❖ Construction
- ❖ Off-Road vehicles
- ❖ Forestry, Wood & Pulp
- ❖ Reclamation & Salvage
- ❖ Oil Field & Sands
- ❖ Demolition Equipment
- ❖ Cooling Solutions
- ❖ Military Apparatus
- ❖ Specialty Use
- ❖ Remote Control
- ❖ Power Generation
- ❖ Emission Controls
- ❖ Integrated Drivers
- ❖ Valve & Pump Controls



HCT Product Sales and Support:

For a full list of authorized distributors worldwide, please visit:

www.hctcontrols.com/distributors/index.htm

Need more information ?

To discuss anything in this brochure, order product, get price and delivery or schedule an application discussion meeting, please contact your nearest HCT distributor who will be pleased to help you.

www.hctcontrols.com

Visit our website for the latest product releases, application ideas, literature and software downloads.



High Country Tek, Inc.

208 Gold Flat Court
Nevada City, CA, 95959
Tel: (1) 530 265 3236
Fax: (1) 530 265 3275

Copyright © High Country Tek, Inc. - 2012

Note: This guide is intended for suggestion only and may contain mistakes and printing errors. Users should check calculations and confirm parts selection will meet system requirements while complying with customer specific or local and state safety requirements at all times. HCT and accepts NO liability for technical mistakes or printing errors, or their consequences.