



High Country Tek, Inc.

Fan Drive Controller Product Overview

January 2015





We Help You Win

Our sales and support personnel understand and readily apply all the hydraulic or electric technologies that are commonly available in cooling solutions. Each representative can discuss the pro's, con's, differences, features, and benefits so you can decide which solution is best for your particular project.

Proven Solution Provider

High Country Tek Inc. has in-house experienced personnel and many successful applications to prove that we can deliver the products and solutions fitting varied customer requirements. Our growing list of global high profile users is testament of our ability to use our independent industry status to design and recommend peripheral hydraulic and system parts completing the optimal package, based on technically superior attributes.

Value in Use

Many companies will and can only equate *value* to dollars alone. HCT has pioneered the value proposition for fan drives by supplying many tools that prove ROI is only a short period away and savings on many levels can be realized for vehicle owners, operators, users and the environment.

Capture The Order

Fast response to your requests is one of our many specialties. We have stock of the most common controllers with pre-written Graphical User Interfaces (GUI's) allowing quick, easy setup for your cooling system. If you have the hydraulic parts, we can get you the controllers to prototype, test and get approved for the application.

Single Direction Hydraulic Fan Controller

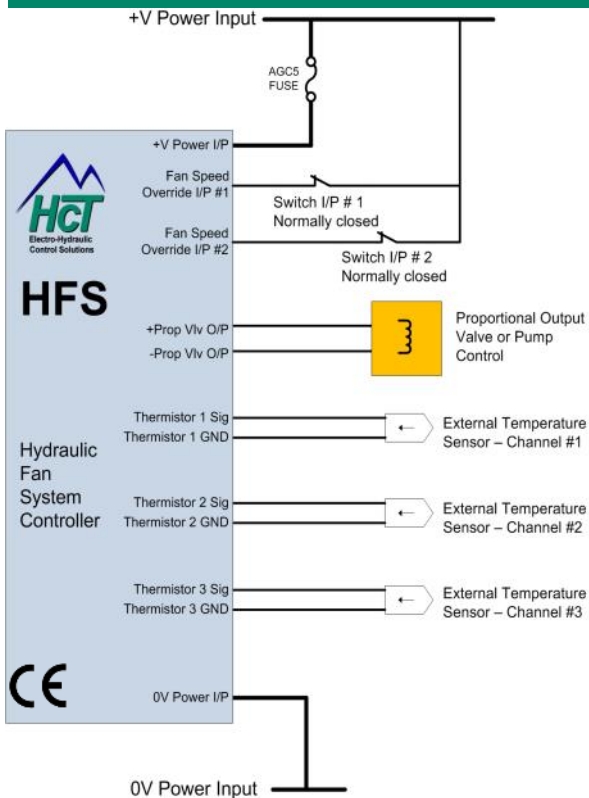

Part No: HFS

Hydraulic Fan System Controller:

- Complete system controller
- Settings by pre-written PC program
- Simple and easy-to-apply
- OEM or retro-fit / repower suitable
- Full CE compliance for global sales
- Industry standard 12 way IP67 connector
- Clear diagnostic, visible LED's
- System 'error' blink code warning
- 9 - 30VDC operational power supply
- Up to 3.3A PWM output - open & short circuit protected
- Discrete thermistor inputs only (Delphi, Ford e.t.c.)
- 2 extra 'switch' override inputs (i.e. air conditioning profile)
- Environmentally hardened, mount anywhere, modular design
- Flame retardant, solid potted module.
- -40 - +85°C extended operational temp. range
- Opto3000 interface communications.



Bi-Directional Hydraulic Fan Controller

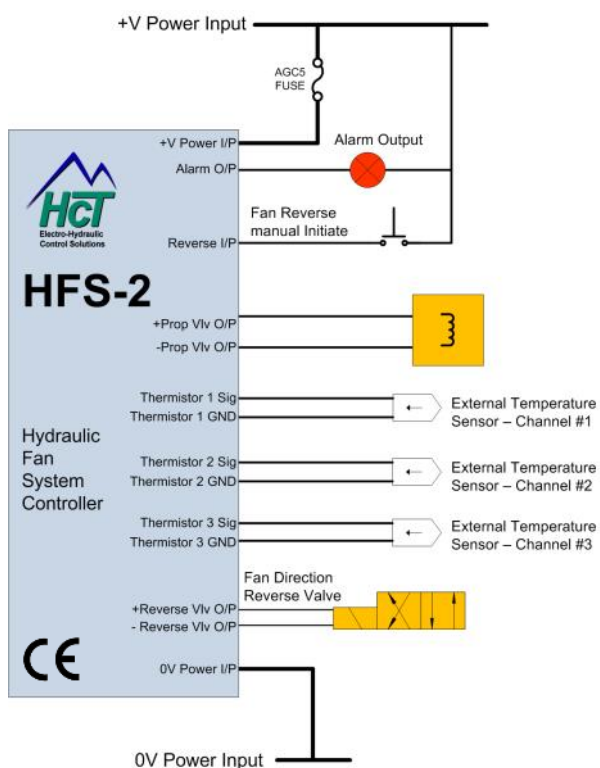

Part No: HFS-2

Hydraulic Fan System Controller:

- Complete system controller
- Settings by pre-written PC program
- **Full CE compliance** for global sales
- Direct to PC Data logging feature
- Clear diagnostic, visible LED's with system 'error' blink code warning
- Wide 9 - 30VDC operational power supply range
- Up to 3.3A PWM and reverse valve drive output
- Alarm output for integrated system interface / shutdown options
- ALL wires to/from module are open & short circuit protected
- Discrete thermistor inputs only (Delphi, Ford e.t.c.)
- Environmentally hardened, mount anywhere, modular design
- Flame retardant, solid potted module.
- -40 - +85°C extended operational temp. range
- Opto3000 interface communications.
- **Optional 'Weather Pack' connectors available**



CAN Based Hydraulic Fan Controller

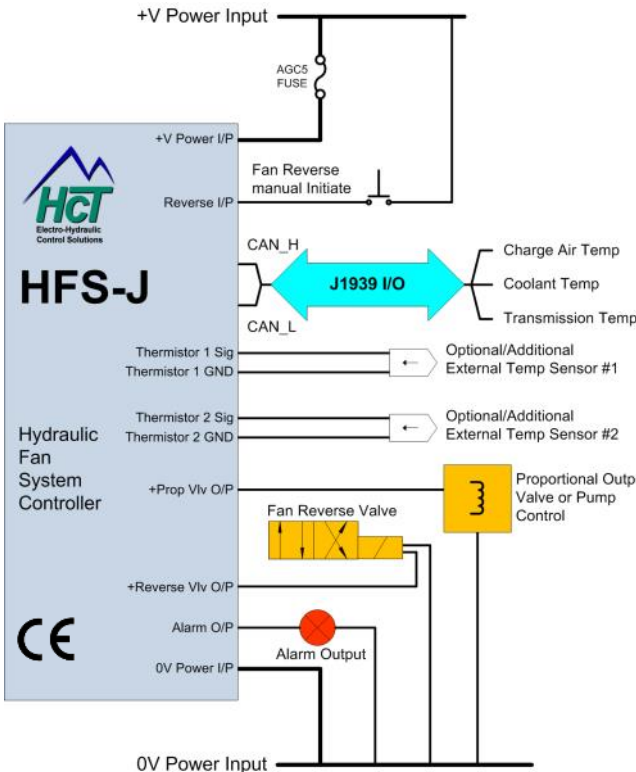

Part No: HFS-J
Hydraulic Fan System Controller:

Bi-direction fan control

- SAE J1939 compatible
- Pre-written PC program
- 9 - 30VDC power supply
- Direct RS232 connection
- Direct to PC Data logging
- Fan reverse feature
- **Full CE compliance** for global sales
- Industry standard 'Deutsch', male 12 IP67 way connector
- Simplified clear diagnostic, visible LED's with error 'blink' code
- Up to 3.3A PWM output - open & short circuit protected
- 2 extra override inputs (i.e. air conditioning profile)
- Environmentally hardened, mount anywhere, modular design
- Flame retardant, solid potted module.
- -40 - +85°C extended operational temp. range



Single E-Fan Array Controller

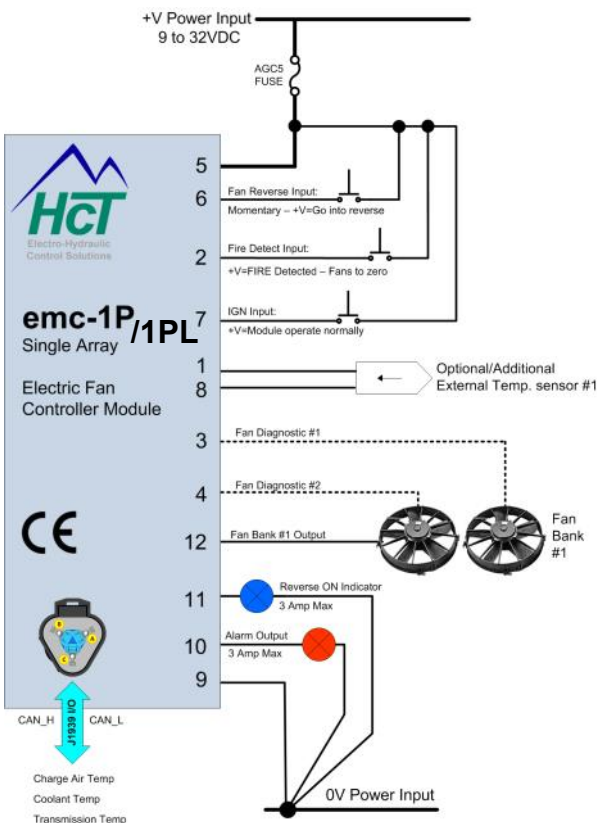

Part No: emc-1P or emc-1PL

e-Fan System Controller:
Drives one (1) low voltage multi-fan array.

Bi-direction e-fan control

- SAE J1939 compatible
- Pre-written PC program (GUI)
- 9 - 30VDC power supply
- RS232 connection to configure
- Data logging to PC via GUI
- **Full CE compliance** for global sales
- Industry standard 'Deutsch', male 12 way IP67 connector
- Simplified clear diagnostic, visible LED's with error 'blink' code
- 1x optional / additional external discrete temperature sensor inputs
- **1x 0-100% PWM output to motor controller**
- 1x 3Amp alarm output for system interface and annunciation
- 1x 3Amp 'reverse sequence in operation' output
- Environmentally hardened, mount anywhere, modular design



Interfaces to VFD High Voltage Motor Drive

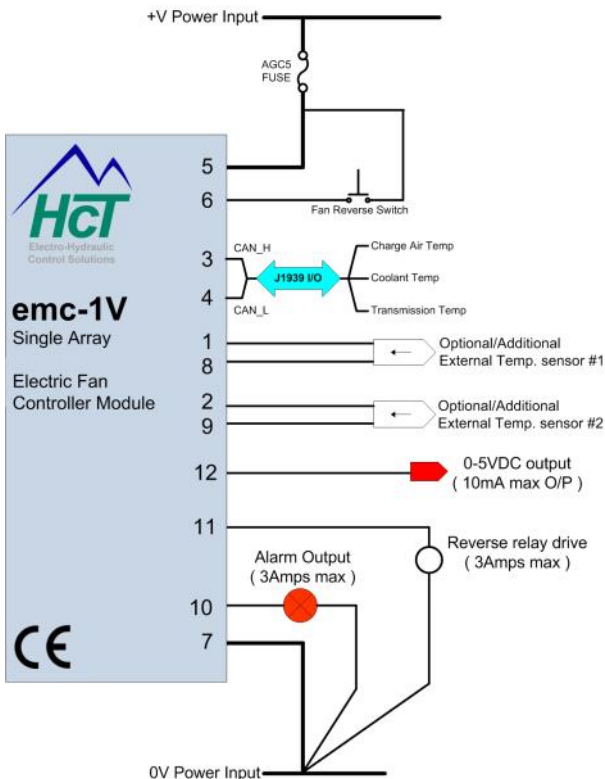

Part No: emc-1V

e-Fan System Controller:

Bi-direction E-Fan control

- SAE J1939 compatible
- Pre-written PC program (GUI)
- 9 - 30VDC power supply
- RS232 connection to configure
- Data logging to PC via GUI
- Full CE compliance for global sales
- Industry standard 'Deutsch', male 12 way IP67 connector
- Simplified clear diagnostic, visible LED's with error 'blink' code
- 2x optional / additional external discrete temperature sensor inputs
- 1x 0-5VDC output to motor controller
- 1x 3Amp alarm output for system interface and annunciation
- 1x 3Amp "reverse sequence in operation" output
- Environmentally hardened, mount anywhere, modular design
- Flame retardant, solid potted module.
- -40 - +85°C extended operational temp. range



Triple E-Fan Array Controller (Programmable)

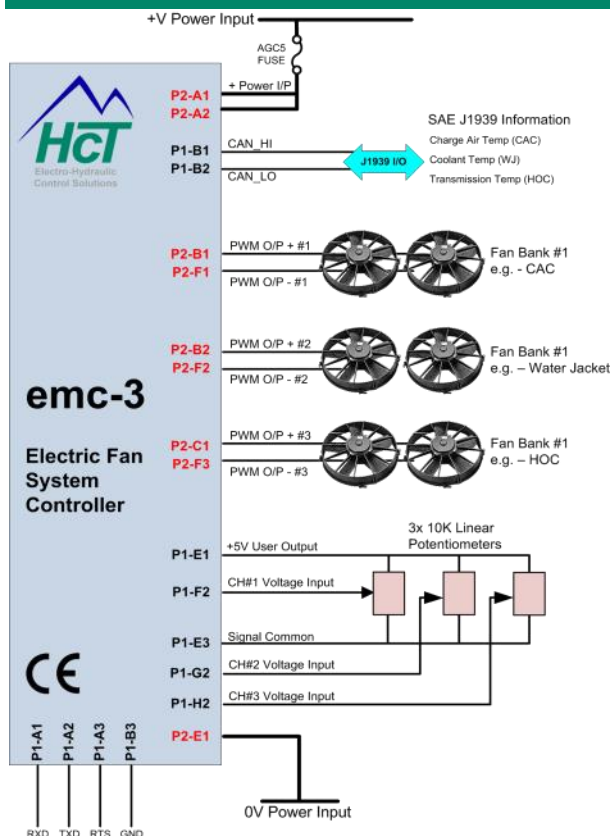

Part No: emc-3

e-Fan System Controller:

Bi-direction E-Fan control

- SAE J1939 compatible
- Starter application program embedded
- Programmed using Intella™ software
- 9 - 30VDC power supply
- RS232 connection to configure
- Full CE compliance for global sales
- Industry standard 'multi-pin heavy duty IP68 connectors
- Simplified clear diagnostic, visible LED's with error 'blink' code
- 3x 0-100% PWM output to motor controller
- Multiple inputs and outputs can be assigned to suit application
- Environmentally hardened, mount anywhere, modular design
- Flame retardant, solid potted module.
- -40 - +85°C extended operational temp. range

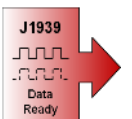

Hybrid Fan Controller (6 Fan Arrays)

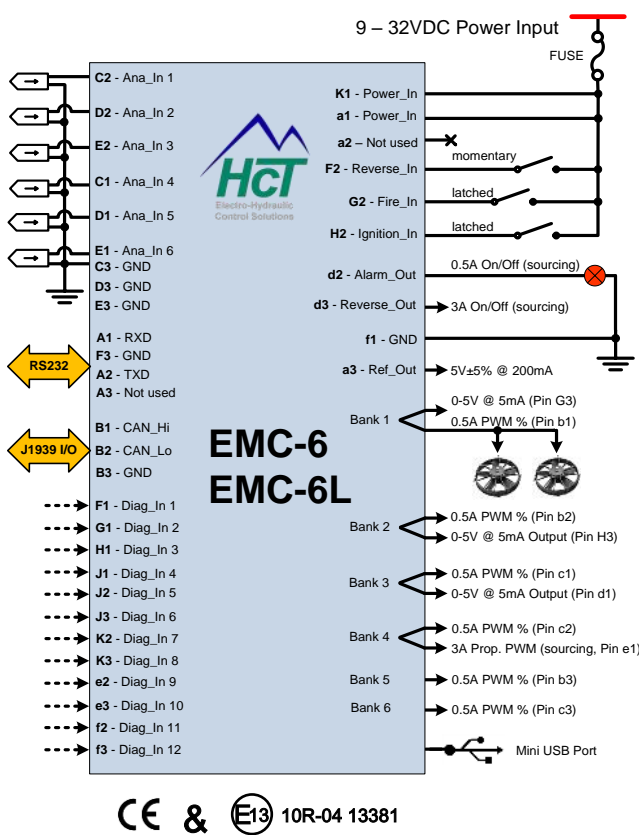

Part No: EMC-6 or EMC-6L

Hybrid System Controller:

E-Fan and Hydraulic fan system control

- Controls 1 Hydraulic or E-Fan bank & up to 5 additional E-Fan banks
- Up to 3x 0-5VDC outputs (water pump, servo control, etc.)
- 12 E-Fan diagnostic inputs (ON/OFF)
- Internal and external data logging
- 10 programmable SAE J1939 CAN messages
- 6 analog inputs for thermistors or potentiometers
- Bi-directional fan control for radiator 'Purge' or 'De-Ice'
- PC based Graphical User Interface (GUI) for system configuration/diagnostics
- SAE J1455 (load dump) compliant power protection
- Industry standard 'multi-pin heavy duty IP68 connectors
- Diagnostic LED's with system "status" blink code indication
- USB or RS-232 communications with PC for set-up/diagnostics
- Designed to operate 12VDC or 24VDC SPAL fan units
- CE and E-Mark certified for the Mass Transit and Off-Highway global industries

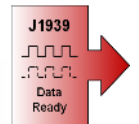

Technical Value & Advantage through Reliable System Solutions

HCT and our distributor network have the experience and personnel to ensure you select the right controller and valve combination to make your application work effectively the first time.

Offering SUN Hydraulics' valves optimizes our packages in the market due to several unique fluid and mechanical features. When the valves are combined with HCT controllers greater gains in efficiency resulting in lower operating costs can be realized. Contact us for more details and let us work with you on your next project build.

Optimized, Compact, Efficient Parts for Successful Applications

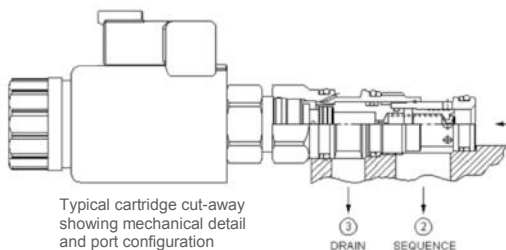

Available Flow USGPM	Available Flow LPM	Max Pressure PSI	Max Pressure Bar	Pilot Cavity	Main Stage Cavity	Seal Options Buna-N	Seal Options Viton
15	60	5000	350	T-8A	T-11A	Yes	Yes
30	120	5000	350	T-8A	T-2A	Yes	Yes
60	240	5000	350	T-8A	T17A	Yes	Yes
120	480	5000	350	T-8A	T-19A	Yes	Yes

Visit our extensive 'Fan Drive' section on the HCT website to see controller solutions and use the free tools to help you with ROI and other customer focused information:

www.hctcontrols.com

Controller Accessories: 'Wet' Fluid Sensor - P/No. 206-00083

- -40 °C to + 150 °C operating range
- 'Wet' fluid means liquids i.e. Coolant, oils e.t.c.
- High Quality Brass Body with thread lock
- Hydraulic Fan drive systems with multi-path coolers
- Closed loop temperature applications
- Direct installation into liquid path
- Hydraulic Manifolds and OEM products
- Direct installation into radiators

Sensor Body:	Brass
Connector Body:	PBT 30% Glass Filled
Hex Size:	18.9mm / 3/4"
Thread Size:	3/8" - 18 NPTF
Thread Sealant:	GM09985473
Sealing Pressure:	145kPa



Controller Accessories: 'Dry' Fluid Sensor - P/No. 206-00084

- -40 °C to + 150 °C operating range
- 'Dry' fluid means gasses i.e. charge air e.t.c.
- Thermoplastic body
- NO galvanic reactions with metals
- Cost effective and robust product design
- Simple assembly process into application
- NO internally moving components

Sensor Body:	PEI (polyetherimide) 30% GF
Connector Body:	PBT 30% Glass Filled
Hex Size:	18.9mm / 3/4"
Thread Size:	3/8" - 18 NPTF
Thread Sealant:	GM09985490
Sealing Pressure:	145kPa
Installation Torque:	10.8 - 16.3 Nm



Controller Accessories: P/No. Opto 3000

- **Used with HFS, HFS-2 controllers only**
- USB to optical head unit
- Used for setup and diagnostics only

NOTE: The Opto 3000 is **NOT CE MARKED** and is for use only during setup and diagnostics and **NOT** Intended to be used as a permanently connected piece of equipment.



Controller Accessories: P/No. 999-10075

- **Use with HFS-J and emc-1 family controllers only**
- RS232 port to 4 way Weather Pack connector
- Used for setup and diagnostics only

NOTE: Contact HCT for USB to RS232 converters if required





- ❖ Mining & Exploration
- ❖ Agriculture
- ❖ Cranes & lifts
- ❖ Refuse & Recycling
- ❖ Construction
- ❖ Off-Road vehicles
- ❖ Forestry, Wood & Pulp
- ❖ Reclamation & Salvage
- ❖ Oil Field & Sands
- ❖ Demolition Equipment
- ❖ Cooling Solutions
- ❖ Military Apparatus
- ❖ Specialty Use
- ❖ Remote Control
- ❖ Power Generation
- ❖ Emission Controls
- ❖ Integrated Drivers
- ❖ Valve & Pump Controls



HCT Product Sales and Support:

For a full list of authorized distributors worldwide,
please visit:

www.hctcontrols.com/distributors/index.htm

For More Information:

Customer Service:

To discuss anything in this brochure, order product, obtain pricing and delivery options, or book a training course, please send an e-mail to us at: info@hctcontrols.com

www.hctcontrols.com



A SUN Hydraulics Company



High Country Tek, Inc.

208 Gold Flat Court
Nevada City, CA, 95959
Tel: (1) 530 265 3236
Fax: (1) 530 265 3275