

Model AS7PROG Autostart 710/720 Programmer

Application Notes

mi5611
revision C, 12th Sept 2011
catalogue section 75



Introduction

Model AS7PROG (stock number 76.70.0015) is a hand-held key-pad that allows programming of Murphy AS710S or AS720S generator controllers. The latest versions of the AS710S and AS720 may also be programmed using a PC and Murphy software model AS7CK (over a communication link), but the compact key-pad provides a convenient method of programming in the field.

WARNING: keypad AS7PROG should not be connected to the Autostart 705 or 730 controllers – please see separate programming instructions for these units.

Each AS7PROG consists of the key-pad plus flying lead connector(s): these are connected to Autostart only when programming is required. For full details about AS7xx series programming, please refer to document mi5265.

Changes to Programmer Specification

The design of the programmer after June 1998 is slightly different to units manufactured before this date. All units feature the keypad, flying lead and 15 way terminal block, but units built after June 1998 are also fitted with a 9 way D-type connector:-

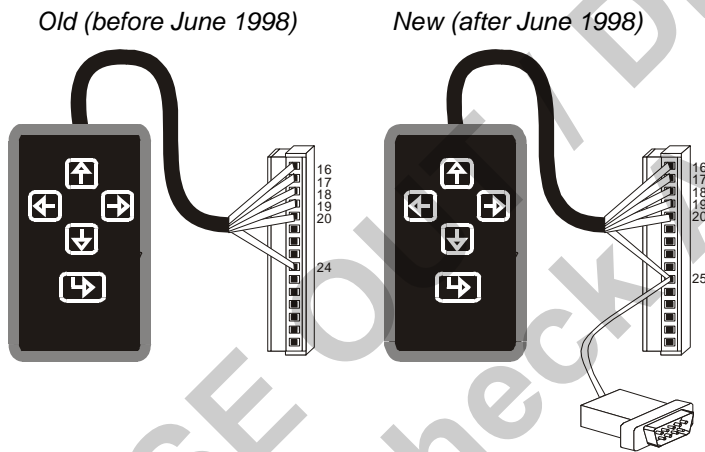

The new specification of programmer is designed to work with the latest versions (V1.0 or higher) of the AS710S and AS720S, also released in June 1998.



Compatibility

Old specification programmers will work with pre-June 1998 versions of the AS710 (V0.12 and lower) and 720 (V0.04 and lower). Old spec. programmers will **NOT** work with (and must not be connected to) Autostarts built after June 1998, but can be simply modified to the latest design (see 'updating' below).

Likewise, new specification programmers will **NOT** operate with older Autostarts, but can be modified back to the old specification if required.

New and old types of AS710 and AS720 controllers are distinguished by the communication port at the rear of the units:-

Old AS710
(before June 1998)

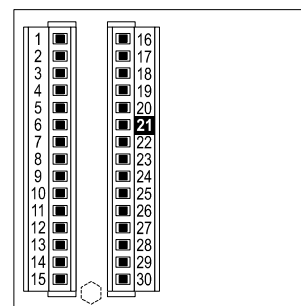

New AS710S
(after June 1998)

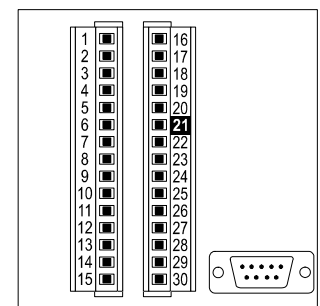

For full details about the connection and use of the hand-held programmer, please refer to document mi5265.

FW MURPHY
P.O. Box 470248, Tulsa, Oklahoma 74147 USA
+1 918 317 4100 Fax: +1 918 317 4266
E-mail: sales@fwmurphy.com

INDUSTRIAL PANEL DIVISION
Fax: +1 918 317 4124
E-mail: ipdsales@fwmurphy.com

MURPHY POWER IGNITION
Website: www.murphy-pi.com

CONTROL SYSTEMS AND SERVICES DIVISION
P.O. Box 1819, Rosenberg, Texas 77471 USA
Phone: +1 281 633 4500 Fax: +1 281 633 4588
E-mail: css-solutions@fwmurphy.com

FRANK W. MURPHY LTD.
Church Road, Laverstock,
Salisbury, SP1 1QZ, United Kingdom
Tel: +44 1722 410055
Fax: +44 1722 410088
E-mail: sales@fwmurphy.co.uk
Web: www.fwmurphy.co.uk

COMPUTRONIC CONTROLS
41 - 46 Railway Terrace, Netchells,
Birmingham, B7 5NG, United Kingdom
E-mail: sales@comptroniccontrols.com
Web: www.comptroniccontrols.com

FW MURPHY INSTRUMENTS (HANGZHOU) CO., LTD.
77 23rd Street, Hangzhou Economic & Technological Development Area
Hangzhou, Zhejiang 310018, China
Phone: +86 571 8788 6060 Fax: +86 571 8684 8878
E-mail: apsales@fwmurphy.com



USA-ISO 9001:2008 FM 28221
UK-ISO 9001:2008 FM 29422
CHINA-ISO 9001:2008 FM 523851
Registered Facilities



Updating an old specification programmer

Technical Background

On older Autostarts, pin 24 (the alarm output) gives a negative DC signal when the Autostart is in program mode. This negative signal is used as a common feed for the push-button switches in the keypad unit. When each button is pushed, the negative DC signal is fed back into the appropriate Autostart input (pins 16 to 20), causing the Autostart to be re-programmed.

On the latest specification Autostarts, pin 24 does not give a negative DC signal, and can in certain circumstances give a positive DC output (which, if fed through to the latest Autostarts, would damage analogue sender inputs 16 and 17).

The required negative signal is therefore derived from the Autostart's communication port, through the new D-connector. Also, this negative signal must be routed via pin 25 of the connector, rather than pin 24, in order to avoid a potential short circuit with a positive DC signal on pin 24.

Modifying the programmer unit to latest specification

Old specification units may be updated by ordering Murphy model AS7CJ (stock code 76.70.0119), which comprises the new D-connector and flying lead. The extra components are added as follows:-

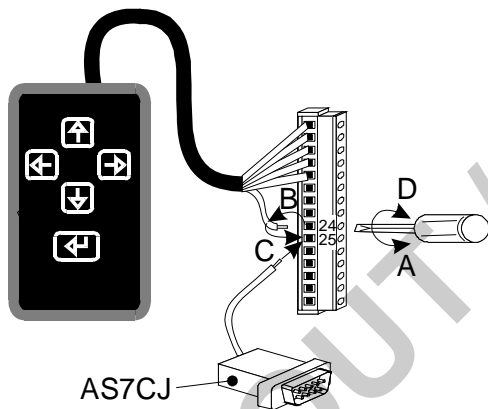

- On the programmer unit connection block, loosen screw terminals 24 (containing the single white wire). and 25.
- Remove the white wire from pin 24.
- Re-insert the white wire into pin 25, along with the single wire from the D-connector (AS7CJ).
- Retighten terminals 25 and 24.

Alternatively, a flying lead (without the D-connector) may be wired into programmer pin 25 as above, and the flying lead connected to battery negative DC, e.g. on pin 1 of the Autostart's other terminal block.



WARNING: an incorrect connection to pin 25 (e.g. to positive DC) will cause damage to the Autostart.

Further information

Document	Description
ms5259	AS710 bulletin and specification
mi5262	AS710 installation reference sheet
m010801	AS720 bulletin and specification
mi5263	AS720 installation reference sheet
mi5265	AS7xx program reference and check sheets
mi5266	AS7xx PC software and communications