

CANstart™ 9641/9642

Engine and Generator Controls

00-02-0673
revision B, 2013-06-07
section 40 & 75



Installation Instructions

Please read the following information before installing. A visual inspection of this product for damage during shipping is recommended before installation. It is your responsibility to ensure that qualified mechanical and electrical technicians install this product. If in doubt, please contact your local Murphy representative.

General Information

WARNING

BEFORE BEGINNING INSTALLATION OF THIS PRODUCT

- ✓ Disconnect all electrical power to the machine
- ✓ Make sure the machine cannot operate during installation
- ✓ Follow all safety warnings of the machine manufacturer
- ✓ Read and follow all installation instructions

CANstart™ 9641 and 9642 modules provide manual or automatic start/stop control, panel gauge driving, fault indication and auxiliary shutdown protection for ECU-controlled, CANbus SAE J1939 compatible engines. These compact controllers can be used with auto-start pumps, generators and other engine-driven applications.

Auto or manual control is by a 4 position keyswitch, with 6 LEDs for indication of status and faults – see ‘front view’ diagram for details. Electrical connection and configuration options are at the rear – see ‘Rear view, connection and settings’ diagram.

For each CANstart ordered, the following is supplied:

- 1 x CANstart module (see below right for model options), fitted with 4 x panel mounting clips
- 2 x keys
- these instructions

Panel installation

CANstart is designed for front-of-panel mounting in a DIN standard 92 x 92 mm (3.6 x 3.6 in.) cut-out. Allow 90mm / 3.6 in. behind the panel for the case depth, keyswitch and wiring.

Secure the case to the panel with the two ratcheted mounting clips:

1. Remove the plastic mounting clips from the CANstart case: release each clip's ratchet mechanism (A), then slide the clip back and off the case (B).
2. At the front of the panel, insert the CANstart (without clips) into the panel cut-out (C).
3. At the rear of the panel, refit the two mounting clips into the slots on the CANstart case (D). Slide each clip forward until the arms (E) are secured behind the panel face. Ratchet mechanism (F) prevents the clip from moving backwards.



Specifications

Power supply

Operating voltage, steady state: 8 to 32 VDC
Operating voltage, brown out / cranking: 5 VDC minimum
Current consumption: < 100mA

Inputs

CANbus:

SAE J1939 protocol, switchable 120 Ohm terminating resistor
Auxiliary shutdown (x2): close to negative DC during fault
Auto start & stop (x2): close to/open from positive DC to activate

Outputs (all ratings non-reactive)

Run (ECU), start (crank):

positive DC (protected FET), 6A max @ 32 VDC

Alarm, auto mode, engine running:

negative DC (open collector transistor), 250mA max @ 32 VDC

Oil pressure gauge:

suitable for Murphy, VDO 5 or 10 Bar, Datcon 7 or 10 Bar

Engine temperature gauge: suitable for Murphy, VDO or Datcon

Tachometer: for use with charge alternator driven tachometers

Adjustable settings

Model 9641 (variable speed engines)

Overspeed level: 1250 – 2800 RPM (50 RPM increments), or ‘off’

Model 9642 (fixed speed engines/gensets)

Nominal speed: 1500 or 1800 RPM

Overspeed level: 1 – 15% of nominal speed (1% increments), or ‘off’

Physical

Electromagnetic compatibility: 2004/108/EC

Case material: polycarbonate / polyester

Overall dimensions (w x h x d): 96 x 96x 131mm / 3.8 x 3.8 x 5.2 in.

Panel cut-out size: DIN 92 x 92mm / 3.6 x 3.6 in.

Weight: approx 240g / 0.6 lb

Operating temperature: –20 to +75 °C / –4 to +167 °F

Model options

CST9641 K2

Model:

CST9641 For variable speed engines, overspeed setting range 1250-2800 RPM*

CST9642 For fixed speed engines/gensets, overspeed setting range 100-115% of 1500/1800 RPM*

Keyswitch type:

K2 Type 2, rubberised

* Default overspeed settings are:-

CST9641: 1250 RPM

CST9642: 110% of 1500 or 1800 RPM (please specify).

Non-standard (NS) settings/options are available to order.

General Information (cont.)

Front view and operation

LED indication

◐ flashing ◑ constant

Green. ECU status:

◐ CAN inactive ◑ CAN active.

Red. Oil pressure fault:

◐ warning ◑ shutdown.

Red. Coolant temperature fault:

◐ warning ◑ shutdown.

Red. Engine speed fault:

◐ overspeed shutdown.

Red. Charge fail warning.

Red. ECU/auxiliary fault:

◐ ECU shutdown fault.

◐ (50/50 on/off) ECU warning fault.

◐ (1 on pulse) aux. 1 shutdown.

◐ (2 on pulses) aux. 2 shutdown.

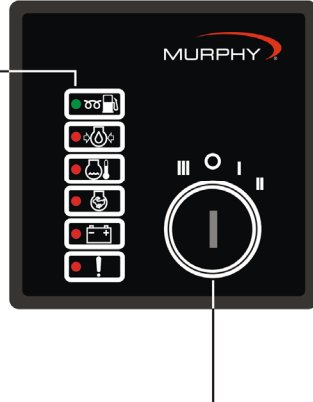

4 position keyswitch:

○ **Off/Reset.** Removes power, de-activates the Run (ECU) output and resets any latched overspeed or aux input fault.

| **Run.** Activates the Run (ECU) output (green LED flashes) and waits for ECU to respond (green LED constant). The CANstart inputs and J1939 CANbus are then monitored for faults, with warning/shutdown LED indication as detailed above.

|| **Start/crank.** Maintains the Run output and activates the Start (crank) output. This position spring-returns to I (Run) on release.

||| **Auto mode.** Automatic start, run and stop triggered from remote contacts. In standby mode, CAN and aux fault LEDs give a short flash every 5 secs.

Rear view, connection and settings

Connection

- 1 – DC power supply
- 2 + DC power supply
- 3 run (ECU) output, + DC, 6A max
- 4 start (crank) output, + DC, 6A max
- 5 alarm output, – DC, 250mA max
- 6 charge fail (alternator WL)
- 7 aux 1 input, – DC to activate
- 8 aux 2 input, – DC to activate
- 9 oil pressure gauge output
- 10 coolant temp gauge output
- 11 tachometer output
- 12 CAN screen
- 13 CAN high
- 14 CAN low
- 15 remote start, close to + DC
- 16 remote stop, open from + DC
- 17 auto mode output, – DC, 250mA max
- 18 engine running output, – DC, 250mA max
- 19 no connection

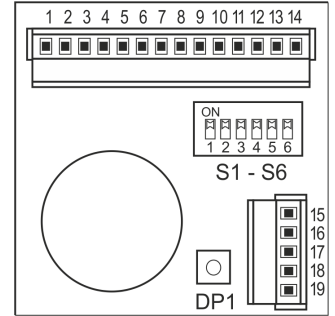

Configuration

Before CANstart electrical connection or use, DIP switches S1 to S5 and Digital potentiometer DP1 must be configured for correct operation.

S1 – S5: DIP switch settings

The table right shows the configuration options for S1 to S5.

Switches S1 to S3 configure the tachometer, oil pressure and coolant temperature gauge outputs for different gauge types.

Switch S4 allows the 120 Ohm CANbus terminating resistor to be in-circuit (if CANstart is at the end of a CANbus network), or removed (if CANstart is between other devices on the network).

Switch S5 is used with DP1 below to set an engine overspeed shutdown level.

S1 – S5 DIL switch settings

Note: switch S6 reserved for future use.

switch position	▲ on (up)	▼ off (down)	options (* default settings)				
S1	S2	S3	S4	S5			
▲	▲	▲			Murphy temp. and pressure gauges *		
▼	▲	▲			Datcon temp. and 0 – 7 bar pressure gauges		
▼	▲	▼			Datcon temp. and 0 – 10 bar pressure		
▲	▼	▲			VDO temp. and 0 – 5 bar pressure gauges		
▲	▼	▼			VDO temp. and 0 – 10 bar pressure gauges		
			▲		CAN 120 Ohm terminating resistor in circuit *		
			▼		CAN 120 Ohm terminating resistor removed		
				▲	Sets speed nominal or range for DP1 below:		
				▼	see installation instructions for full details.		

DP1: Engine overspeed shutdown level

DP1 is a 16-way digital potentiometer that, with DIP switch S5, allows the setting of an engine overspeed shutdown level. If the actual engine speed (determined by ECU-transmitted J1939 data) exceeds the set level, CANstart initiates an engine shutdown. Note: the CANstart overspeed feature operates in addition to any ECU overspeed protection.

CANstart model 9641 provides overspeed settings between 1250 and 2750 RPM (in 50 RPM increments) for general purpose, variable speed engines. Model 9642 allows settings of 1 to 15% above either 1500 or 1800 RPM fixed speed engines, e.g. as used in 50 or 60 Hz gensets. On both models, the overspeed protection can be set to 'off' (i.e. disabled).

DP1 and S5 settings are: -

DP1 position:	0	1	2	3	4	5	6	7	8	9	A	B	C	D	E	F
Model 9641, variable speed engines:																
S5 on (up), RPM	Off	1250	1300	1350	1400	1450	1500	1550	1600	1650	1700	1750	1800	1850	1900	1950
S5 off (down), RPM	2000	2050	2100	2150	2200	2250	2300	2350	2400	2450	2500	2550	2600	2650	2700	2750
Model 9642, fixed speed engines/gensets:																
S5 on, % above 1500 RPM	Off	1%	2%	3%	4%	5%	6%	7%	8%	9%	10%	11%	12%	13%	14%	15%
S5 off, % above 1800 RPM	Off	1%	2%	3%	4%	5%	6%	7%	8%	9%	10%	11%	12%	13%	14%	15%

Electrical Connection

Electrical connection to 0.5 – 1.5 mm² / 16 – 20 AWG panel wiring is through a pair of two-part (removable) screw terminal blocks:

- Pre-strip 8 to 10 mm / 0.3 to 0.4 in. of insulation from each wire.
- Insert wire(s) into the correct terminal receptacle, ensuring insulation is clear of the terminal.
- Tighten the terminal screw using a 3mm flathead screwdriver, ensuring the wire is secure.

General connection recommendations

Murphy make the following recommendations for the electrical connection of engine and generator controllers.

- Minimise controller output load current (i.e. wear/tear and potential damage) by using slave relays between the controller outputs and high power end-devices, e.g. starter solenoids.
- Suppress (at source) electrical interference from panel relay and engine solenoid coils, using flywheel diode or proprietary snubber/suppression components as appropriate.
- Use separate routing for AC and DC wiring harnesses.
- Use separate wiring for a) connection of battery charger to battery, and b) connection of battery to panel DC supply. Separate wiring will reduce high frequency battery charger output noise on the panel DC power supply.

Terminal functions

Pin Function

1 Negative DC power supply

2 Positive DC power supply

CANstart operates with any smooth DC / battery voltage in the range 8 – 32V. Supply brown-out protection is fitted as standard. Connect a 5 Amp anti-surge fuse in the positive DC line (pin 2).

3 Run (ECU) output

4 Start (crank) output

These outputs provide control signals for the engine's ECU Run input and starter motor. Both outputs use solid-state FET devices, which give a positive DC signal (rated 6 Amp max) when active.

The Run output (pin 3) is used to control the ECU Run input. Before connection, check the engine documentation for ECU Run input polarity requirements. If the ECU requires a switched negative/ground or 'open to start' connection, use an interposing relay with suppressed coil between pin 3 and the ECU Run input.

Pin 3 activates as soon as the key is switched to the **I** (RUN) position, and remains at positive DC as long as the engine is required to Run. Pin 3 de-activates if the key is switched to **O** (off/reset), if the ECU transmits an engine shutdown fault code, if a CANstart auxiliary fault input is activated, or if the overspeed fault levels are exceeded.

The Start output (pin 4) operates when the operator switches the key to the (spring-loaded) **II** (start) position. A slave relay with suppressed coil is recommended between pin 4 and the starter motor solenoid coil.

5 Alarm output

The alarm output activates during fault conditions, triggered either from the ECU-transmitted J1939 message, or from CANstart's auxiliary inputs or overspeed shutdown feature.

Pin 5 is an open collector transistor output: activation gives a negative DC signal rated 250mA @ 32VDC max. The output typically drives a relay coil, which in turn drives an audible or visible alarm. A flywheel diode or other suppression device should be connected across all relay coils - see 'typical connection' above.

Typical connection

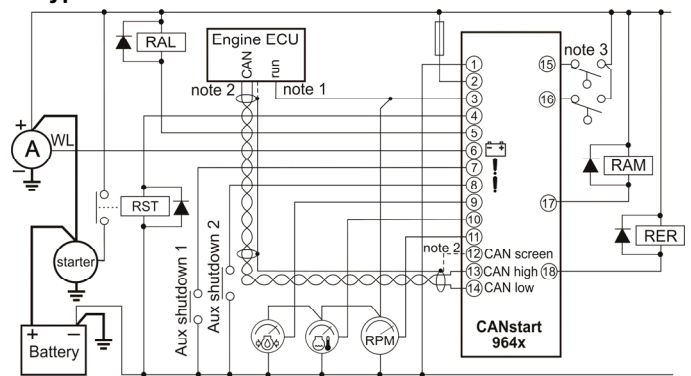

Notes:-

1. Wiring shown for ECU with close to positive to run input. An additional interposing fuse or relay may be required between pin 3 and ECU: check engine documentation for ECU 'run' input requirements.
2. ECU CANbus screen is typically grounded at one end only. Check ECU documentation for details
3. Inputs shown for pump-out application: start on high level (closing contact), stop on low level (opening contact)

6 Charge fail

The charge fail (LED lights, but there is no shutdown or alarm output, when pin 6 is connected to battery negative. When using a charge alternator, connect pin 6 to the alternator warning lamp (WL) terminal. Note: pin 6 supplies the alternator excitation current.

7 Auxiliary 1 fault input

8 Auxiliary 2 fault input

These inputs allow engine shutdowns to be triggered by remote switch or relay contacts. Connection of these inputs to battery negative causes deactivation of the Run output (pin 3), activation of the alarm output (pin 5) and the flashing of the Aux fault (LED) – see operation section for details.

To reset an auxiliary fault condition, turn the key to **O** (Off) or remove the DC power supply.

9 Oil pressure gauge output

10 Coolant temperature gauge output

11 Tachometer output

These outputs are used to drive a tachometer and electric gauges, based on ECU-transmitted J1939 engine data.

Pins 9 and 10 give a variable current output for driving oil pressure and coolant temperature electric gauges. The outputs can operate with several different manufacturers' gauge types, as set using DIP switches S1, S2 and S3 – see Configuration Settings section above.

Pin 11 gives a square wave output (0V to battery positive DC) with a frequency proportional to engine speed. At 1500 RPM engine speed, the output frequency is approximately 121 Hz, suitable for driving charge alternator based tachometers such as the Murphy AT(H)A series. Pin 11 gives no output below 100 RPM engine speed.

Connect each output to the appropriate gauge and tachometer signal input terminals. Connect gauge and tachometer negative terminals to battery negative, ideally via dedicated wiring to CANstart pin 1. (The use of dedicated return wiring to pin 1, rather than via a chassis/ground return, minimises gauge inaccuracies caused by ground noise.)

12 CAN shield/screen

13 CAN High

14 CAN Low

These connections receive ECU-transmitted J1939 CANbus data, including engine parameters and fault codes. Wiring and connection should be made in accordance with the SAE J1939 standard and ECU/engine manufacturer's guidelines. Attention should be paid to the wiring type (normally twisted pair, often with a shield/screen), and to the shield/screen ground connection (normally only at one end of CANbus network, often at the ECU).

CANstart is supplied with a 120 Ohm CANbus terminating resistor in circuit, enabled/disabled using DIP switch S4.

Electrical Connection (cont.)

15 Auto start input 16 Auto stop input

With the keyswitch in position III (Auto mode), inputs 15 and 16 are used with remote start contacts to trigger auto start, run and stop. Remote contacts are connected between the inputs and battery positive DC in one of two ways:

- Start and stop via single maintained contact. Connect pin 15 to battery positive to start and run the engine; make pin 16 open-circuit to stop the engine. Pin 16 is left open circuit.
- Start and stop via 2 momentary contacts, e.g. high and low float level switches. With pin 16 connected to battery

positive DC, a momentary (pulsed) connection of pin 15 to battery positive causes an engine start. CANstart keeps the engine running until pin 16 is momentarily made open circuit.

17 Auto mode output 18 Engine running output

These open-collector (negative DC) outputs can be used to signal 'auto mode' and 'engine running' (above 500RPM crank cut speed). Electrical connections and ratings are as for pin 5 (alarm output).

19 No connection

Operation and Maintenance

Operator control of the engine is through the 4 position keyswitch:

- O Off / reset.** Removes DC power from the CANstart, de-activating the Run (ECU) output (stopping the engine) and resetting any CANstart fault conditions, e.g. overspeed or auxiliary input.
- I Run.** When the key is switched to I:
 - The Run (ECU) output activates, signalling the ECU that the engine is required to run.
 - The Status LED lights, initially flashing, then continuous – see 'LED operation' below.
 - The charge fail LED lights – see 'LED operation' below.
 The Run (ECU) output deactivates:
 - If CANstart receives (from the ECU) a J1939 fault shutdown message – see 'LED operation' below.
 - If engine speed (from ECU J1939 data) exceeds CANstart's overspeed limit, as set by S5 and DP1.
 - If a CANstart auxiliary shutdown input is activated.
- II Start.** Activates the Start (crank) output. Keyswitch position II is sprung-loaded to return to the I (Run) position.
- III Auto.** Engine start and stop is controlled by inputs 15 and 16.

LED operation



Status (Power / CAN / mode):

- Lights continuously when CANstart is in run mode and valid J1939 CAN messages are present.
- Flashes if CANstart is powered, but no valid CAN messages are detected.
- Short flash every 5 secs (with General Fault LED) when unit is in Auto (standby) mode.



Oil pressure fault. Lights in response to ECU-transmitted J1939 messages:

- Lights continuously following a shutdown fault
- Flashes during a warning only fault.



Coolant temperature fault. Lights in response to ECU-transmitted J1939 messages:

- Lights continuously following a shutdown fault
- Flashes during a warning only fault.



Overspeed fault. Lights continuously following an overspeed shutdown fault (whether triggered by ECU or CANstart).



Charge fail fault. Lights continuously during a charge fail condition, whenever CANstart terminal 6 is connected to battery negative. If CANstart is used with a charge alternator, the LED also lights when the engine is stationary (indicating that CANstart is providing charge alternator excitation current).



General Fault. Lights in response to both ECU-transmitted J1939 fault messages and CANstart auxiliary inputs:

- Continuously lit indicates an ECU-initiated fault shutdown
- A regular 50/50 on/off flashing indicates one or more ECU-transmitted fault warning messages. The LED goes out if the ECU stops sending fault messages.
- One short flash followed by a long pause indicates an engine shutdown triggered through CANstart's 'aux 1 fault' input.
- Two short flashes followed by a long pause indicate an engine shutdown triggered through CANstart's 'aux 2 fault' input.
- Short flash every 5 secs (with Status LED) when unit is in Auto (standby) mode.

Maintenance and Warranty

CANstart contains no user-serviceable parts. Maintenance is therefore limited to the following preventative checks:

- Check that CANstart electrical connections are secure.
- Check that the case is mounted securely, with vibration and environmental exposure minimised where possible. The case may be wiped with a clean, damp cloth. Do not use cleaning solvents.

CANstart is supplied with a two year warranty on parts and workmanship. A copy of the full warranty terms and conditions is available at www.fwmurphy.com/warranty. In the event of a fault or technical query, and before returning equipment, please contact your Murphy representative for technical support.

ENOVATION CONTROLS CORPORATE HEADQUARTERS
5311 S 122ND EAST AVENUE, TULSA, OK 74146, USA

ENOVATION CONTROLS – SAN ANTONIO OFFICE
5757 FARINON DRIVE, SAN ANTONIO, TX 78249, USA

ENOVATION CONTROLS – HOUSTON OFFICE
105 RANDON DYER RD, ROSENBERG, TX 77471, USA

ENOVATION CONTROLS LTD. – UNITED KINGDOM
CHURCH ROAD, LAVERSTOCK, SALISBURY, SP1 1GZ, UK

MURPHY ECONTROLS TECHNOLOGIES – CHINA
77 23RD STREET, HANGZHOU ECONOMIC &
TECHNOLOGICAL DEVELOPMENT AREA,
HANGZHOU, ZHEJIANG 310018 CHINA

SALES & SUPPORT, NORTH AMERICA

MURPHY PRODUCTS:
PHONE: 918 317 4100
FAX: 918 317 4266
EMAIL: SALES@FWMURPHY.COM
WWW.FWMURPHY.COM

ECONTROLS PRODUCTS:
PHONE: 210 495 9772
FAX: 210 495 9791
EMAIL: INFO@ECONTROLS.COM
WWW.ECONTROLS.COM

MURPHY CONTROL SYSTEMS & SERVICES
PHONE: 281 633 4500
FAX: 281 633 4588
EMAIL: CSS-SOLUTIONS@FWMURPHY.COM

MURPHY INDUSTRIAL PANEL DIVISION
PHONE: 918 317 4100
FAX: 918 317 4124
EMAIL: IPDSALES@FWMURPHY.COM

SALES & SUPPORT, INTERNATIONAL

EUROPE, MIDDLE EAST & AFRICA
PHONE: +44 1722 410055
FAX: +44 1722 410088
EMAIL: SALES@FWMURPHY.CO.UK
WWW.FWMURPHY.CO.UK

CHINA
PHONE: +86 571 8788 6060
FAX: +86 571 8684 8878
EMAIL: APSALES@FWMURPHY.COM

LATIN AMERICA & CARIBBEAN
PHONE: +1 918 317 2500
EMAIL: LASALES@FWMURPHY.COM

SOUTH KOREA
PHONE: +82 70 7951 4100
EMAIL: SKOREASALES@FWMURPHY.COM

INDIA
PHONE: +91 91581 37633
EMAIL: INDIASALES@FWMURPHY.COM

ISO 9001
REGISTERED



USA (TULSA) - ISO9001-2008 FM 28221
USA (ROSENBERG) - ISO9001-2008 FM 28221
UK - ISO9001-2008 FM 29422
CHINA - ISO9001-2008 FM 52385
Registered facilities